

Electronics World

APRIL, 1968
60 CENTS

THE TECHNICAL INSTITUTE GRADUATE—

How Does He Compare with the B.S.E.E.?

HOW TO TUNE YOUR COLOR-TV SET

NEW BAND-PASS FILTER DESIGNS

**SPECIAL
ISSUE**

POWER SUPPLIES



**“Get more
education
or
get out of
electronics
...that’s my advice.”**



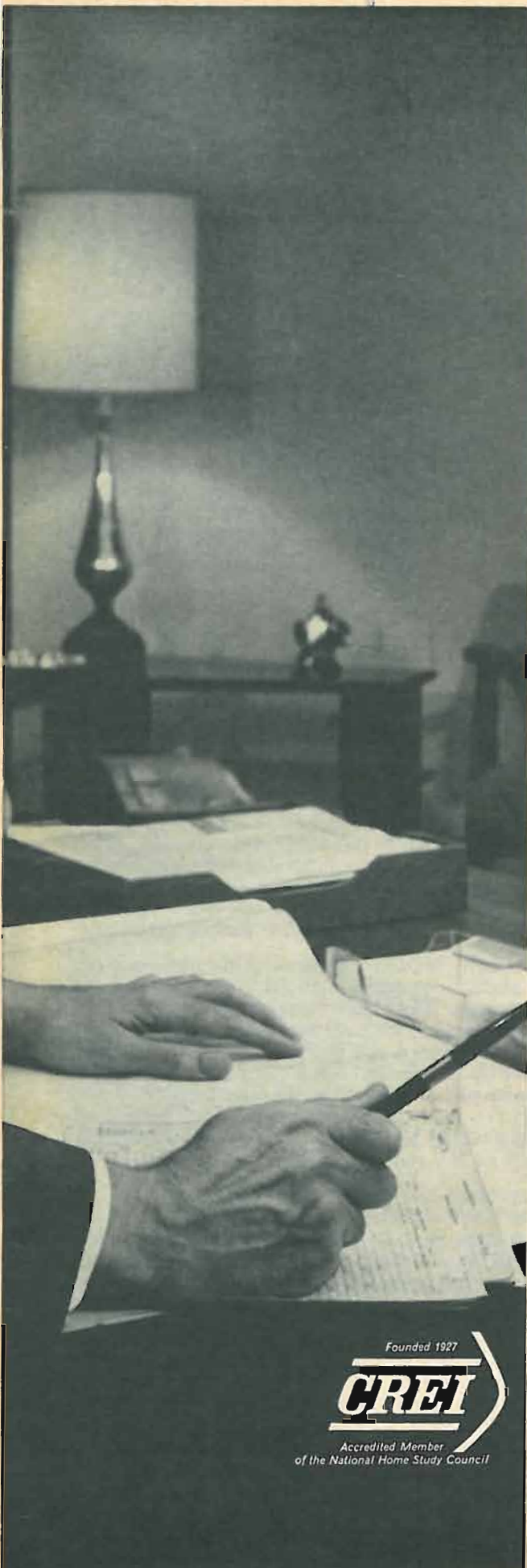

Founded 1927
CREI
Accredited Member
of the National Home Study Council

Ask any man who really knows the electronics industry.

Opportunities are few for men without advanced technical education. If you stay on that level, you'll never make much money. And you'll be among the first to go in a layoff.

But, if you supplement your experience with more education in electronics, you can become a specialist. You'll enjoy good income and excellent security. You won't have to worry about automation or advances in technology putting you out of a job.

How can you get the additional education you must have to protect your future—and the future of those who depend on you? Going back to school isn't easy for a man with a job and family obligations.

CREI Home Study Programs offer you a practical way to get more education without going back to school. You study at home, at your own pace, on your own schedule. And you study with the assurance that what you learn can be applied on the job immediately to make you worth more money to your employer.

You're eligible for a CREI Program if you work in electronics and have a high school education. Our FREE book gives complete information. Airmail post-paid card for your copy. If card is detached, use coupon below or write: CREI, Dept. 1104G, 3224 Sixteenth Street, N.W., Washington, D.C. 20010.



The Capitol Radio Engineering Institute
A Division of McGraw-Hill, Inc.
Dept. 1104G, 3224 Sixteenth Street, N.W.
Washington, D.C. 20010

Please send me FREE book describing CREI Programs. I am employed in electronics and have a high school education.

NAME _____ AGE _____

ADDRESS _____

CITY _____ STATE _____ ZIP CODE _____

EMPLOYED BY _____

TYPE OF PRESENT WORK _____ G.I. BILL

I am interested in Electronic Engineering Technology
 Space Electronics Nuclear Engineering Technology
 Industrial Electronics for Automation
 Computer Systems Technology

APPROVED FOR TRAINING UNDER NEW G.I. BILL

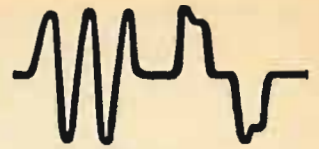

“Trading up” resistors prevents call-backs

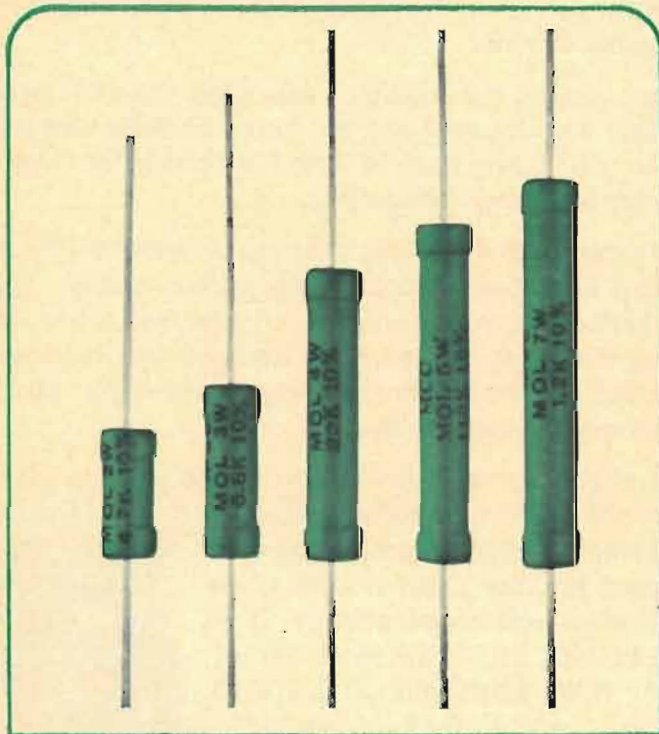

Color television sets contain some potential trouble spots for fixed resistors. Sudden overloads or short-outs of a tube, diode or transistor, or leakage in a by-pass capacitor may cause enough current surge in a carbon resistor to cause it to open or to suddenly increase in value. You wind up with a strange set of symptoms that take a lot of point-to-point testing to unscramble.

EXAMPLE: Suppose a tube or capacitor shorts out. This may cause excessive current drain on the power supply which may affect a resistor in the bleeder network. This resistor may increase in value which would then reduce voltage in subsequent circuits. When this happens, a number of controls must be re-adjusted. By replacing the resistor with a Mallory MOL, the set is brought back to normal operation and the MOL construction virtually precludes this type of difficulty happening in the future.

Granted, resistors don't fail as often as other components. But when it happens, you can take out a simple insurance policy against call-backs by replacing faulty carbon resistors with Mallory MOL's. For just a few pennies more, you're putting a world of extra life and stability in a critical part of the circuit.

In a nutshell, MOL's are metal oxide film resistors with stability comparable to wire-wounds, but far lower in cost. They can stand brief overloads of several times rated wattage without damage. Humidity and vibration don't bother them. They're non-inductive up to 250 mc, so you can use them in rf and if sections without a worry. As for stability, we've run them on load cycle tests up to 10,000 hours and resistance values hold steady within 1%! No wonder every major TV manufacturer is using them.

MOL resistors are usually a bit larger than carbon types, so you may have to bend a few leads to fit them in. They come in 2, 3, 4, 5 and 7 watt sizes (which is more than you'll need in most carbon resistor replacements), in resistance values up to 500K.

Your Mallory distributor stocks MOL's in the values you'll need. And he has an up-to-date cross-reference list which shows you the Mallory part numbers to specify for popular TV sets, by manufacturer and chassis number. See him, or write to Mallory Distributor Products Company, a division of P. R. Mallory & Co. Inc., Indianapolis, Indiana 46206.

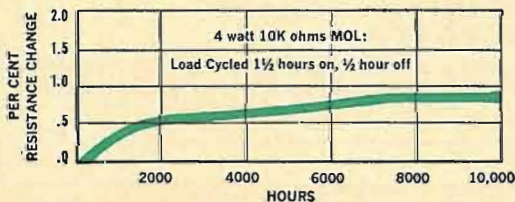

Typical stability test data: 10,000-hour load cycling test. Average resistance change is less than 1%!

DON'T FORGET TO ASK 'EM — *“What else needs fixing?”*



THIS MONTH'S COVER illustrates a number of typical power supplies and ties in with our special 24-page section on this important topic. In the center foreground we show an uncased, nuclear-radiation-hardened inverter for aircraft and missile applications, made by Lear Siegler. At the extreme left is Lambda Model LP 412FM, a regulated supply with an output of up to 40 V d.c. at 0.7 A. Next is Kepco's Model OPS 2000-MU, an operational supply with 2000-V, 10-mA output. A Sola Type CVDC, rated at 18 V d.c. at 10 A is next, in the center background. The rack-mountable unit at the right is the Sorensen (Raytheon) ACR-1000 a.c. regulator using SCR's. Atop this, at the left, is a Harrison (Hewlett-Packard) 6291A d.c. supply producing up to 40 V at 5 A. The final unit, at the right, is Power Designs Model 2005, a precision power source producing up to 20 V d.c. at 500 mA. Photo: Dirone-Denner.



Publisher
PHILLIP T. HEFFERNAN

Editor
WM. A. STOCKLIN

Technical Editor
MILTON S. SNITZER

Associate Editors
W. J. EVANZIA
P. B. HOEFER

Contributing Editors
WALTER H. BUCHSBAUM
Prof. ARTHUR H. SEIDMAN
FOREST H. BELT

Art Editor
HERBERT L. SILBERMANN

Art and Drafting
J. A. GOLANEK

Advertising Sales Manager
LAWRENCE SPORN

Advertising Service Manager
ARDYS C. MORAN

Electronics World

APRIL 1968

VOL. 79, No. 4

CONTENTS

27 The Technical Institute Graduate—How Does He Compare? *J. H. McElroy*

The graduate with an ASEE degree or equivalent is not being fully used despite the shortage of technical personnel. The author, who has worked both as technician and engineer, blames this on members of the scientific and professional community who do not realize the depth and quality of a technician's training. Included is a surprising comparison between university and tech-institute courses.

31 New Filter Designs *William M. Stutz*

These Butterworth, Chebyshev, and elliptic types are more accurate in response and easier to design than many of the older types.

32 Recent Developments in Electronics

34 Tuning in on Color *Forest H. Belt*

Here's the right way to tune a color set and an explanation of what the controls do. Circuits that are built into new receivers to make tuning easier are included.

SPECIAL SECTION: POWER SUPPLIES

37 Power-Supply Principles and Parameters *Edward S. Brenner*

41 How to Measure Power-Supply Performance *B. C. Biega*

44 IC Voltage Regulators for Power Supplies *A. H. Seidman*

46 Power-Supply Programming *Paul S. Birman*

48 Often-Used Power-Supply Terms

49 Protection Circuits for Solid-State Power Supplies *Arthur M. Darbie*

52 "Why So Many Batteries?" *Howard J. Strauss*

54 A.C. Regulated Power Supplies *Paul Muchnick*

56 Power-Supply Modules

57 Power Inverters and Converters *Benjamin Barron*

60 Potent Power Packs

76 Radar Coupler

86 New R.F. Standard

6 EW Lab Tested

University "Studio Pro 120" FM-Stereo Receiver
BSR McDonald 600/M44-E Automatic Turntable

62 Electronics & Farming *John Frye*

72 Test Equipment Product Report

RCA Model WT-501A Transistor Tester
Honeywell Model 333 "Digitest" Digital Voltmeter
Eico Model 235 V. T. V. M.

MONTHLY FEATURES

- | | |
|------------------------------------|-------------------------------------|
| 4 Coming Next Month | 23 Reflections on the News |
| 13 Radio & Television News | 90 Book Reviews |
| 16 Letters from Our Readers | 92 New Products & Literature |

Electronics World: Published monthly by Ziff-Davis Publishing Company at 307 North Michigan Ave., Chicago, Illinois 60601. One year subscription \$6.00. Second Class Postage paid at Chicago, Illinois and at additional mailing offices. Subscription service and Forms 3579: Portland Place, Boulder, Colorado 80302. Copyright © 1968 by Ziff-Davis Publishing Company. All rights reserved.

BY CORRESPONDENCE

prepares you for your

A. S. E. E.

(Associate in Science in Electronics Engineering)

DEGREE

In today's world of electronics employment, an FCC license is important — sometimes essential but it's not enough! Without further education, you can't make it to the top. Get your FCC license without fail, but don't stop there. To prepare for the best jobs, continue your electronics education and get your Associate Degree in Electronics Engineering.

This is good common sense for those who want to make more money in electronics. It also makes sense to prepare for your FCC license with the School that gives degree credit for your license training — and with the School that can then take you from the FCC license level to the Degree level.

Accreditation, and G.I. Bill Approval

Grantham School of Electronics is *accredited* by the Accrediting Commission of the National Home Study Council, and is *approved* for both correspondence and resident training under the G.I. Bill. Just mail the coupon, or write or telephone us for full information without obligation.

It's Your Move

The move you make today can shape your future. Begin now with a step in the right direction — Step #1 — and then follow through with Steps #2, #3, and #4.

Step #1 is a simple request for full information on the Grantham Associate Degree Program in Electronics. You take this step by filling out and mailing the coupon shown below. We'll send full information by return *mail*. No salesman will call.

Step #2 is earning your FCC first class radiotelephone LICENSE and radar endorsement. You complete this step in the first two semesters of the Grantham educational program (by correspondence, or Washington resident classes).

Step #3 is earning your ASEE DEGREE. This degree is conferred when you have earned credit for the Grantham course, one semester of which must be taken in residence if you have less than one year of practical experience in electronics.

Step #4 is getting a better job, greater prestige, higher pay on the basis of your extensive knowledge of electronics.

It's your move! Why not begin now with Step #1.

Grantham School of Electronics

• Established in 1951 •

1505 N. Western Ave. 818 18th Street, N.W.
Hollywood, Calif. 90027 or Washington, D.C. 20006

Grantham School of Electronics EW-4-68
1505 N. Western Ave., Hollywood, Calif. 90027

Please mail me your free catalog, which explains how Grantham training can prepare me for my FCC License and Associate Degree in electronics. I understand no salesman will call.

Name _____ Age _____

Address _____

City _____ State _____ Zip _____

COMING NEXT MONTH

SPECIAL FEATURE ARTICLE ON: COLOR-BAR GENERATORS



"Stability" is the keyword in an article on the color-bar generators appearing in next month's issue. It discusses some of the newest solid-state test equipment. Included is a buyer's guide which lists the characteristics and prices of 12 solid-state and 3 tube-type units now available. Covered are generators from Amphenol, B&K, Conar, Eico, Heath, Hickok, Knight-Kit, Leader, Lectrotech, RCA, and Sencore. The circuitry of each is discussed fully.

THE CO₂ LASER: BRIGHT BEAMS OF ENERGY

The carbon-dioxide laser is probably the best example of high-power laser development. It can generate up to 3000 watts continuously and is about 200 times more efficient than other lasers.

DIGITAL PULSES— A NEW FORM OF ANALOG

There are three basic types of analog-to-digital conversion systems. This article describes them and illustrates how they are used in various computer systems.

D.C. POWER TRANSMISSION

Amid the controversy among American electrical engineers, the installation of extremely high-voltage d.c. (EHV) power

transmission systems is being pushed in this country, Europe, and in the U.S.S.R.

TUNING AND DAMPING BASS-REFLEX ENCLOSURES

In a number of experimental tests, the author found that bigger ports and better damping materials provided a smoother response than in many standard cabinet designs.

TACTILE COMMUNICATIONS SYSTEMS

In space, underseas, and on land many conventional communications systems can be easily overloaded. The military and some researchers think that the skin can be an important receptor, reducing the load on the eyes and ears.

All these and many more interesting and informative articles will be yours in the May issue of ELECTRONICS WORLD . . . on sale April 18th.

ZIFF-DAVIS PUBLISHING COMPANY

William B. Ziff
Chairman of the Board (1946-1953)

William Ziff
President

W. Bradford Briggs
Executive Vice President

Hershel B. Sarbin
Senior Vice President

Philip Sine
Financial Vice President

Walter S. Mills, Jr.
Vice President, Circulation

Stanley R. Greenfield
Vice President, Marketing

Phillip T. Heffernan
Vice President, Electronics Division

Frank Pomerantz
Vice President, Creative Services

Arthur W. Butzow
Vice President, Production

Edward D. Muhlfeld
Vice President, Aviation Division

Irwin Robinson
Vice President, Travel Division

Editorial and Executive Offices
One Park Avenue
New York, New York 10016 212 679-7200

NEW YORK OFFICE 212 679-7200
Joseph E. Halloran

MIDWESTERN OFFICE
307 North Michigan Avenue
Chicago, Illinois 60601 312 726-0892
Midwestern Advertising Manager, Royce Richard

WESTERN OFFICE
9025 Wilshire Boulevard
Beverly Hills, California 90211
213 CRestview 4-0265; BRoadshow 2-1161
Western Advertising Manager, Bud Dean

JAPAN
James Yagi
Ishikawa Mansion
#4, Sakuragaoka
Shibuya-ku, Tokyo
462-2911-3

CIRCULATION OFFICE
Portland Place, Boulder, Colorado 80302



Radio & TV News • Radio News • Radio-Electronic Engineering Trademarks Reg. U.S. Pat. Off.

SUBSCRIPTION SERVICE: Forms 3579 and all subscription correspondence should be addressed to Electronics World, Circulation Department, Portland Place, Boulder, Colorado 80302. Please allow at least six weeks for change of address. Include your old address, as well as new—enclosing if possible an address label from a recent issue.

EDITORIAL CONTRIBUTIONS must be accompanied by return postage and will be handled with reasonable care; however publisher assumes no responsibility for return or safety of art work, photographs, or manuscripts.

ELECTRONICS WORLD (April, 1968, Vol. 79, No. 4). Published monthly at 307 North Michigan Avenue, Chicago, Illinois 60601, by Ziff-Davis Publishing Company—also the publishers of Airline Management and Marketing, Boating, Business & Commercial Aviation, Car and Driver, Cycle, Flying, HiFi/Stereo Review, Modern Bride, Popular Electronics, Popular Photography, Skiing, Skiing Area News, and Skiing Trade News. (Travel Weekly is published by Robinson Publications, Inc., a subsidiary of Ziff-Davis Publishing Company.) One year subscription rate for U.S., U.S. Possessions, and Canada, \$6.00; all other countries, \$7.00. Second Class postage paid at Chicago, Illinois and at additional mailing offices. Authorized as second class mail by the Post Office Department, Ottawa, Canada and for payment of postage in cash.

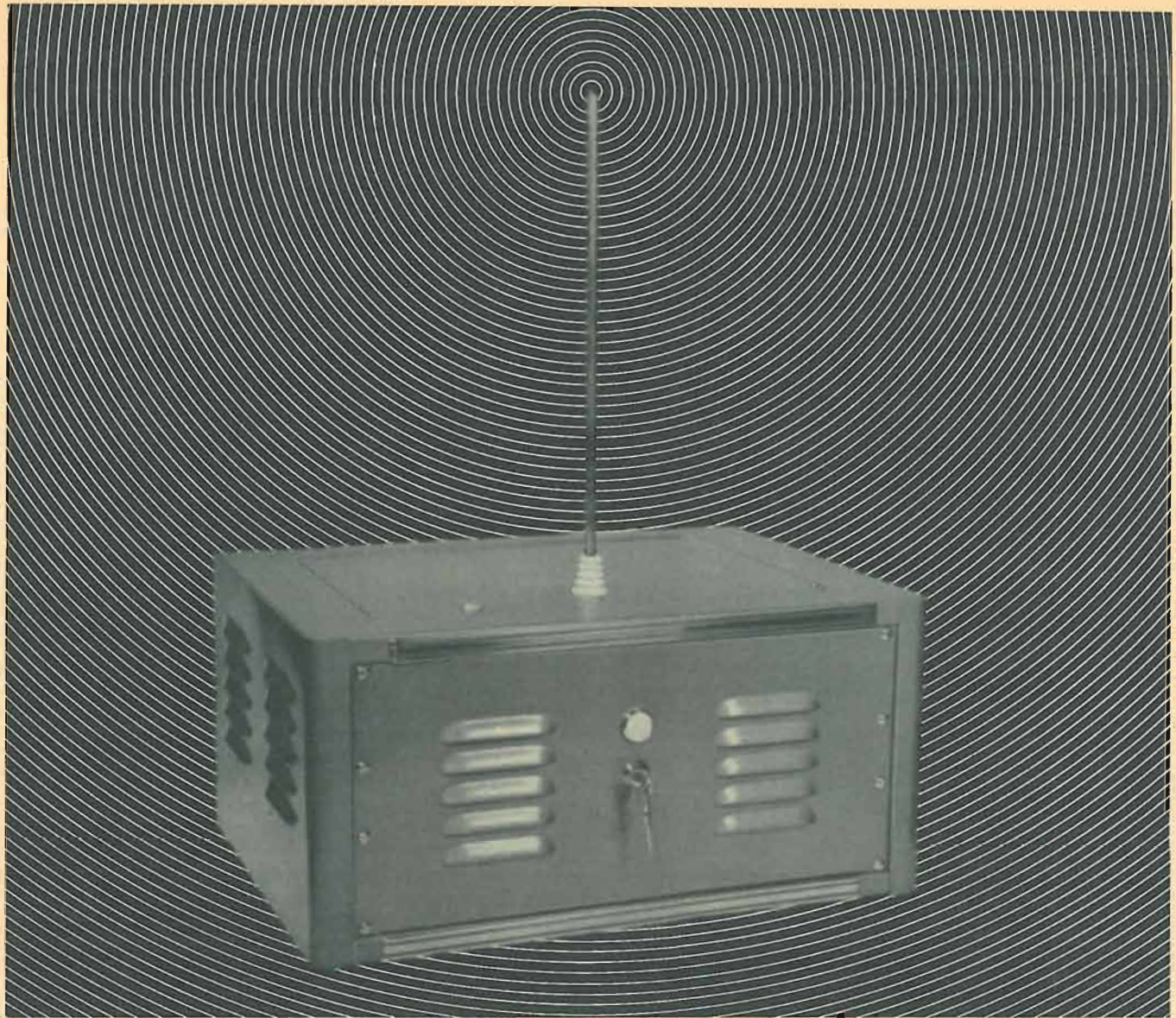

You are now in Radar Sentry Alarm's r.f. microwave field. Don't move a muscle!

This security system is so sensitive, it can be adjusted to detect the motion of your arm turning this page.

And if this Portable Model Unit were within 35 feet of you and you moved... people up to a half-mile away could hear the siren. Plus with optional equipment, it can detect fire... turn on lights... even notify police.

What does a burglar alarm have to do with you?

Just this: Radar Sentry is no ordinary alarm. It is the most modern and effective security system available. And it's also electronic.

That's why we need you. We need Dealers with technical knowledge. For the most successful Dealers for Radar Sentry Alarm are men who know electronics. This is a product that sells itself when demonstrated properly.

It's been proven time after time. In fact, many of the more than one thousand readers of electronics magazines who became Dealers in the past year — sold a system on their *first* demonstration.

And that's why we need men with technical knowledge and experience.

Men like *you*.

How about it?

Do you want to start a business of your own... or expand your present business with a product that in 8 years has become the world-wide leader in its field?

Do you want to earn up to \$5,000 a year in your spare time?

Do you want to earn \$20,000 and more full time?

We'll show you how.

O.K., now you can move.

Fill out the coupon and get complete Dealer/Distributor information... free.

Mail to: RADAR DEVICES MANUFACTURING CORP.
22003 Harper Ave., St. Clair Shores, Michigan 48080



Please tell me how I can have a business of my own distributing Radar Sentry Alarm Systems. I understand there is no obligation.

Name _____

Address _____

City _____ State & Code _____

EW-4

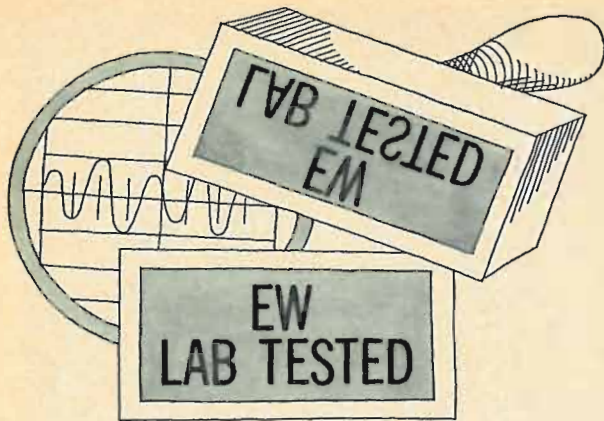

HI-FI PRODUCT REPORT

TESTED BY HIRSCH-HOUCK LABS

University "Studio Pro 120" Receiver
BSR McDonald 600/M44-E Turntable

University "Studio Pro 120" FM-Stereo Receiver

For copy of manufacturer's brochure, circle No. 21 on Reader Service Card.

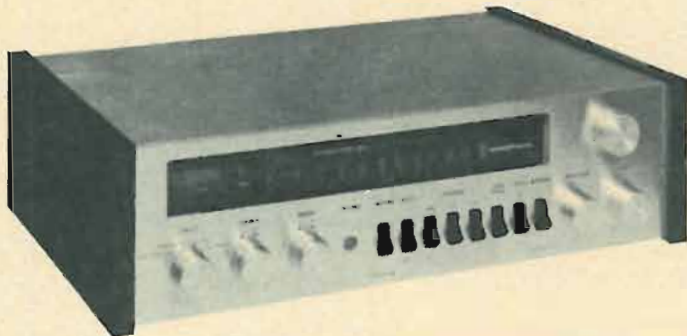

FOR many years, the *University* brand name has been associated with loudspeakers. Now, it is possible to have a music system that is all *University* (except for record-playing components). The new "Studio Pro 120" FM-stereo receiver, the first all-electronic component in the firm's product line, marks the entry of this manufacturer into the growing group of companies which produce all, or most of the components of a complete music system.

The manufacturer has chosen to enter the upper-middle ranks of the rapidly growing stereo-receiver field. The Studio Pro 120 has all the operating flexibility one could want, and uses the latest technological advances in its circuit design. The designers of the receiver have held its price to a reasonable level, yet it can drive any speaker system comfortably and has more than enough

sensitivity for almost any application.

The unit uses all-silicon transistors, including the new plastic-encapsulated power transistors which transfer their heat efficiently to the chassis and do not require massive heat sinks. Because of this and the large radiating surface of the all-metal cabinet, the receiver runs completely cool, even though it has no louvers or ventilating holes. The power supply and output stages are protected by thermal circuit breakers, which reset automatically and eliminate the need for fuses.

The front-end circuits employ MOS-FET stages for low noise and freedom from cross-modulation. In the i.f. section, integrated circuits provide high gain, excellent limiting, and the wide bandwidth necessary for a good capture ratio. The company specifies a 1-dB capture ratio.

Among its many features, the Studio Pro 120 has automatic stereo/mono switching, a tuning meter (zero center), and provision for tape monitoring with a three-head machine while recording from the receiver. The tone controls are concentric, with slip clutches which permit individual adjustment for each channel. A separate volume control and balance control are provided, with the a.c. switch operated by the volume control. There is switchable loudness compensation, as well as low- and high-cut audio filters, a multiplex noise filter, interstation FM noise muting, manual stereo/mono switching effective on all inputs, and a local/remote speaker switch. The stereo-headphone jack on the panel is always energized, although there is no way to silence the speakers except by switching to remote when no speakers are connected to these terminals.

The input selector has four positions: tape head, phono, FM, and auxiliary (high level). Except for this control, all the switches are rocker types, clearly labeled and easy to operate.

The receiver we tested met or surpassed virtually all the specifications for which we were able to test. The FM tuner had a usable sensitivity (IHF) of 2.5 microvolts, very close to its rated 2.3 microvolts. The FM frequency response was +0, -2.5 dB from 30 to 15,000 Hz, with stereo separation of 36 dB at middle frequencies and bet-

(Continued on page 87)

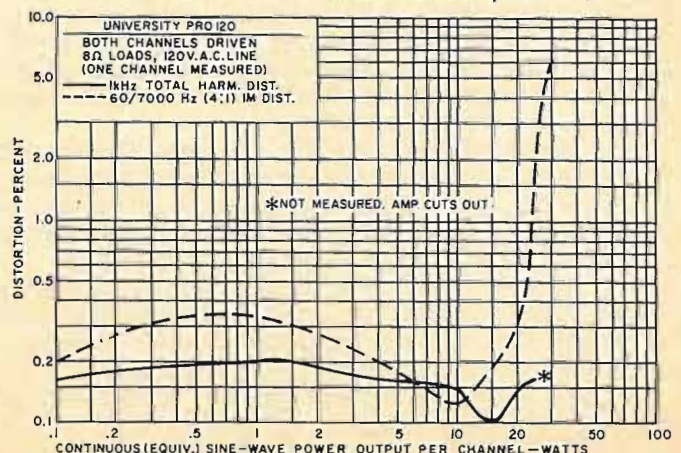
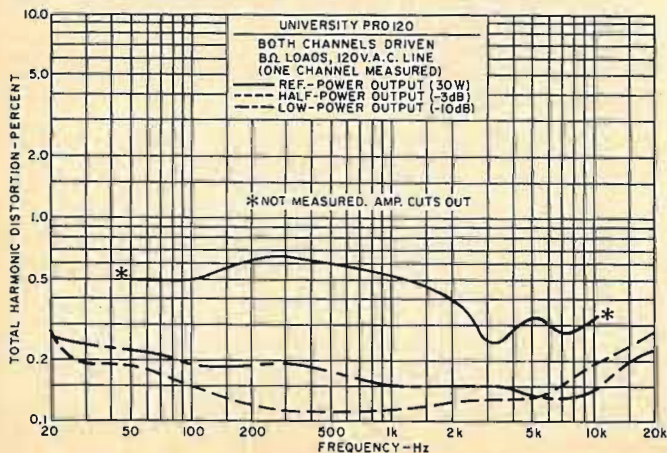

HIGH CURRENT DC AMPLIFIER

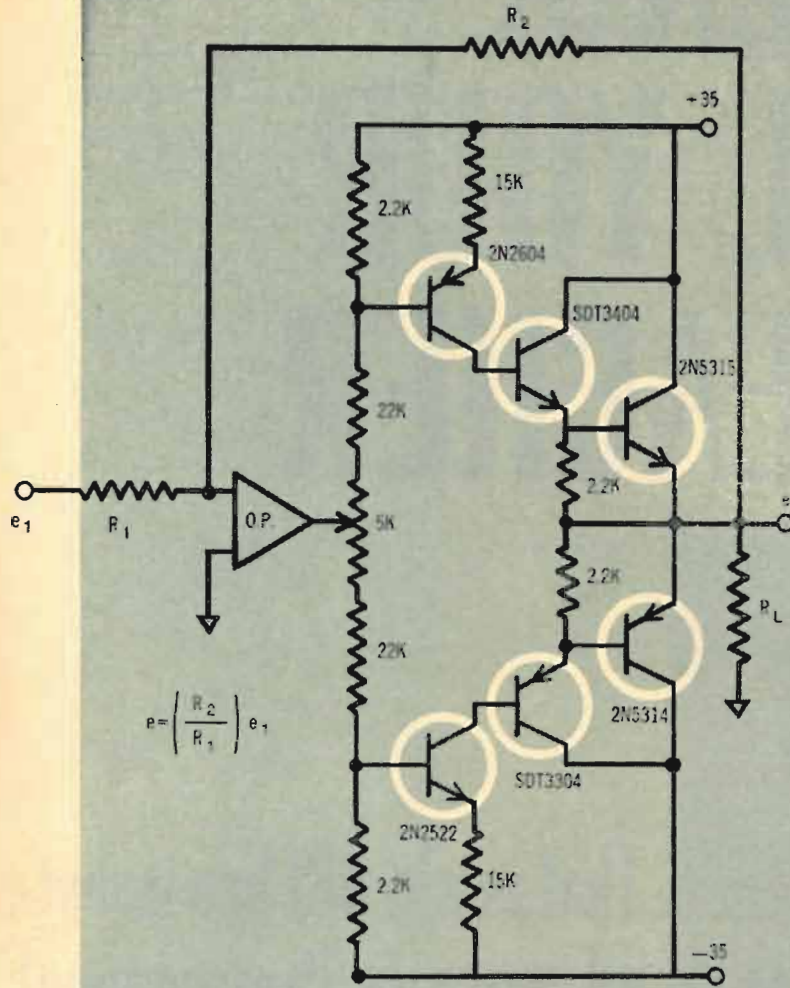

$$P = \left(\frac{R_2}{R_1} \right) e_1$$

20 Amp NPN and PNP Complementary Pairs

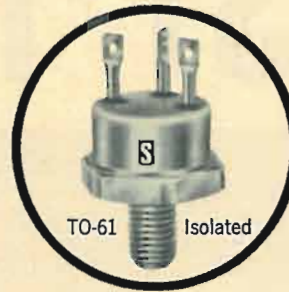

From
Solitron

NPN Type Number TO-61 Isolated	PNP Type Number TO-61 Isolated	MAXIMUM RATINGS			PRIMARY ELECTRICAL CHARACTERISTICS (T _c = 25°C)					
		V _{CEX} Volts	V _{CEO} Volts	V _{EB0} Volts	h _{FE}		V _{CE(sat)} Volts	V _{BE(sat)} Volts	I _{CEX} μA	f _T MHz
					I _C = 20A V _{CE} = 5V	I _C = 10A V _{CE} = 5V				
					Min.	Range	Max.	Max.	Max.	Min.
SDT3201	SDT3101	40	40	6	5	30-90	1.75	2.5	10	30
SDT3202	SDT3102	60	60	6	5	30-90	1.75	2.5	10	30
2N5313	2N5312	80	80	6	5	30-90	1.75	2.5	10	30
2N5315	2N5314	100	100	6	5	30-90	1.75	2.5	10	30

DIAL 1-800-327-3243 FOR A "NO CHARGE" TELEPHONE CALL AND FURTHER INFORMATION.

*When you think of semiconductors...
think Solitron!*

Solitron
DEVICES, INC.

1177 Blue Heron Blvd./Riviera Beach, Florida
TWX: (510) 952-6676

EXPERIENCE IS STILL YOUR BEST TEACHER



That is why NRI has invested more in Professional Lab Equipment than all other home-study schools combined. It makes train-

ing at home in Electronics fast and fascinating. Your hands are trained as well as your head.



**OLDEST AND LARGEST
SCHOOL OF ITS KIND**

Accredited by the Accrediting Commission of the National Home Study Council

You get more for your money from NRI

—more value, more solid experience so essential to careers in Electronics. NRI's pioneering "discovery" method is the result of more than half a century of simplifying, organizing, dramatizing subject matter. In each of NRI's major courses you learn by doing. You demonstrate theory you read in "bite-size" texts programmed with NRI designed-for-learning professional lab equipment. Electronics comes alive in a unique, fascinating way. You'll take pleasure in evidence you can feel and touch of increasing skills in Electronics, as you introduce defects into circuits you build, perform experiments, discover the "why" of circuitry and equipment operation.

Almost without realizing it, the NRI discovery method gives you the professional's most valuable tool—practical experience. You learn maintenance, installation, construction and trouble-shooting of Electronic circuits of any description. Whether your chosen field is Industrial Electronics, Communications or TV-Radio Servicing, NRI prepares you quickly to be employable in this booming field or to earn extra money in your spare time or have your own full-time business. And you start out with training equivalent to months—even years—of on-the-job training.

NRI Has Trained More Men for Electronics Than Any Other School

—By actual count, the number of individuals who have enrolled for Electronics with NRI could easily populate a city the size of New Orleans or Indianapolis. Over three-quarters of a million have enrolled with NRI since 1914. How well NRI training has proved its value is evident from the thousands of letters we receive from graduates. Letters like those excerpted below. Take the first step to a rewarding new career today. Mail the postage-free card. No obligation. No salesman will call. NATIONAL RADIO INSTITUTE, Electronics Division, Washington, D.C. 20016.



L. V. Lynch, Louisville, Ky., was a factory worker with American Tobacco Co., now he's an Electronics Technician with the same firm. "I don't see how the NRI way of teaching could be improved."



Don House, Lubbock, Tex., went into his own Servicing business six months after completing NRI training. This former clothes salesman just bought a new house and reports, "I look forward to making twice as much money as I would have in my former work."

APPROVED UNDER NEW GI BILL. If you served since January 31, 1955, or are in service, check GI line on postage-free card.



G. L. Roberts, Champaign, Ill., is Senior Technician at the U. of Illinois Coordinated Science Laboratory. In two years he received five pay raises. Says Roberts, "I attribute my present position to NRI training."



Ronald L. Ritter of Eatontown, N.J., received a promotion before finishing the NRI Communication course, scoring one of the highest grades in Army proficiency tests. He works with the U.S. Army Electronics Lab, Ft. Monmouth, N.J. "Through NRI, I know I can handle a job of responsibility."



COLOR TV CIRCUITRY COMES ALIVE

as you build, stage-by-stage, the only custom Color-TV engineered for training. You grasp a professional understanding of all color circuits through logical demonstrations never before presented. The TV-Radio Servicing course includes your choice of black and white or color training equipment.



COMMUNICATIONS EXPERIENCE

comparable to many months on the job is yours as you build and use a VTVM with solid-state power supply, perform experiments on transmission line and antenna systems and build and work with an operating, phone-cw, 30-watt transmitter suitable for use on the 80-meter amateur band. Again, no other home-study school offers this equipment. You pass your FCC exams—or get your money back.

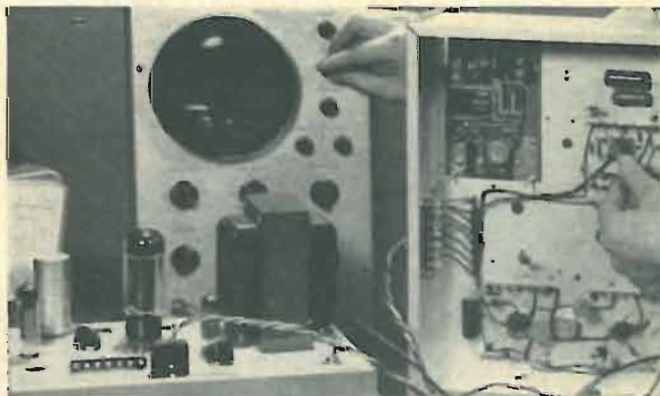

COMPETENT TECHNICAL ABILITY

can be instantly demonstrated by you on completing the NRI course in Industrial Electronics. As you learn, you actually build and use your own motor control circuits, telemetering devices and even digital computer circuits which you program to solve simple problems. All major NRI courses include use of transistors, solid-state devices, printed circuits.

A vital determinant of the quality of an automatic turntable is the tone arm system. Here are some of the tone arm and related features that make the BSR McDonald automatic turntables the sophisticated units they are.



A resiliently mounted coarse and fine Vernier Adjustable Counterweight delicately counterbalances the tone arm assuring sensitive and accurate tracking.

Micrometer Stylus Pressure Adjustment permits $\frac{1}{3}$ gram settings all the way from 0 to 6 grams. This important part of the tone arm assures perfect stylus pressure in accordance with cartridge specifications.



A much appreciated feature built into all BSR McDonald automatic turntables is the Cueing and Pause Control Lever. It permits pausing at any listening point and then gently permits the tone arm to be lowered into the very same groove. Positioning of the stylus anywhere on the record is accomplished without fear of damaging the record or the cartridge.

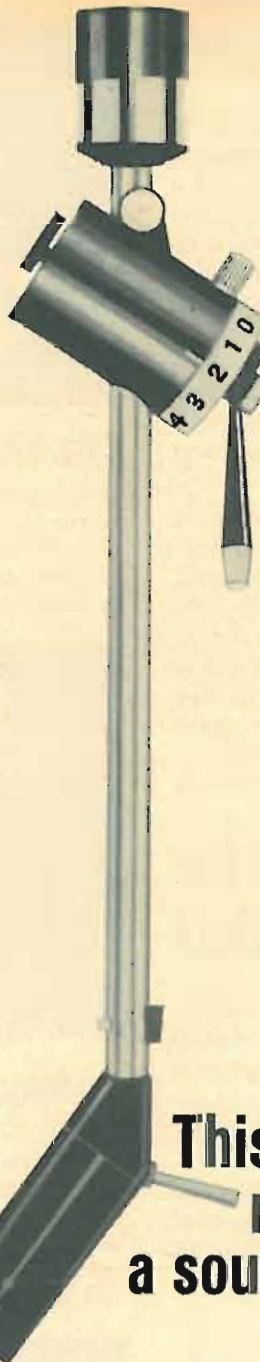

To achieve the ultimate in performance, BSR McDonald has brought to perfection the Anti-Skate Control. This adjustable dynamic control applies a continuously corrected degree of compensation as required for all groove diameters. It neutralizes inward skating force and eliminates distortion caused by unequal side wall pressure on the stylus. All of the BSR McDonald automatic turntables incorporate anti-skate.

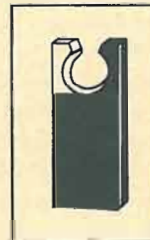
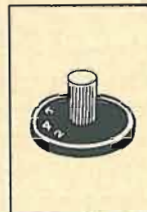

After the last record has played on any of the three BSR McDonald automatic turntables, the tone arm automatically returns to the Locking Rest. In conjunction with this action, the On-Off-Reject lever automatically shifts into the Off position which securely locks the tone arm in its cradle to protect it from accidental drops and resulting stylus damage.

All BSR McDonald automatic turntables have a Clip-In Cartridge Head. This lightweight tone arm head, with finger lift and clip-in cartridge holder, provides universal mounting and quick change facility. It can accommodate practically every contemporary cartridge currently on the market.

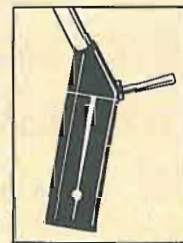

**This unique tone arm
makes BSR McDonald
a sound investment.**



Please send free literature on all the new BSR McDonald automatic turntables.

Name _____

Address _____

City _____ State _____ Zip _____



McDONALD

PRECISION CRAFTED IN GREAT BRITAIN
BSR (USA) LTD., BLAUVELT, N.Y. 10913

BSR McDonald 600 • Suggested Retail Price \$74.50

CIRCLE NO. 123 ON READER SERVICE CARD

Radio & Television news

By FOREST H. BELT / Contributing Editor

Standardizing Black-and-White Portables

Foreign competition has forced the portable-TV industry to re-evaluate ways to push prices down on domestic models. Production economy by standardization is one recurring answer. One step is suggested by *Sylvania*--pick one picture-tube size and stick with it. A 12-inch "standard" tube is being offered at a price lower than ever before, in OEM quantities. A survey (by a different pix-tube maker) has shown the 12-inch size to be the preferred one among buyers of small TV sets.

The argument for a standard CRT size to be used by all portable-TV builders: it's a step toward automated production lines. The ideal situation, according to some, is an all-industry black-and-white TV chassis, with a standard picture tube and standard circuitry. This is reminiscent of the "all-American five" a.c.-d.c. table radios developed in the years before transistors.

General Electric took another tack toward the same goal last year when it introduced a "4 plus 1" portable receiver prototype. So far, little more has been heard of this concept. The set was designed around four multipurpose compaction tubes, but also boasted new circuit ideas--none of which was made public. The aim was to bring out a set that could retail for under \$50. That figure seems to be considered the "ultimate" at present.

Standard CRT and circuitry are two steps in the right direction. However, the still-sliding prices of integrated circuits and semiconductor products suggest that the real breakthrough may come with an "all-American dozen" of these devices, designed into a package using circuits as yet untried in consumer equipment. We can at least gamble that this won't appear first in some foreign brand.

Asian Low-Cost TV Idea

The standardization idea isn't confined to the U.S. The Asian Broadcast Union, meeting in Singapore, emphasized the need for a low-cost TV set for the mass populations in Asian countries. The attending members felt this could help, as much as any one thing, to speed up development in "backward" countries. The receiver must be simple to operate and easy to service, besides being cheap to produce. ABU members hope for a receiver that could receive TV signals directly from a satellite. That's quite a combination of specifications; we can help them hope.

TV Service Pricing

Beware! That's the advice of the Federal Trade Commission (FTC) to anyone planning to "suggest" prices to charge for television service. The National Alliance of Television and Electronics Service Associations (NATESA) received this dictum from the FTC, regarding a standard rate schedule NATESA was preparing. Just why the FTC considers this practice would have an "overriding adverse effect of reducing competition" isn't exactly clear. Other industries have been doing it for years; published manuals of standard repair charges are common in the auto industry.

Perhaps a standard-time schedule would be more acceptable. With it, the shop-owner could base his flat rates on normal average testing and replacement times; he would then apply to the time whatever hourly rate is appropriate to his locality and his business judgment. This system has been used successfully by a number of service shops around the country.

The X-Ray Credibility Gap

It seems one monkey that is on the back of the TV industry to stay--as if there weren't enough already--is the one of color sets radiating x-rays. The more the industry tries to prove there's no real danger, the worse becomes the confusion. What began as an unfortunate mistake has become an official concern and, if publicity continues, will become a matter of public worry. Even the President saw fit to mention it in his State of the Union speech. Yet, so far, only 1% of possible buyers questioned in a sample survey indicated any worry about color-TV radiation.

The set manufacturers keep making several important points, even though no one listens much: (1) There is no excessive radiation from any properly installed and adjusted color-TV. (2) Any radiations from maladjusted sets are *soft* x-rays, having little penetration capability. (3) Checks of receivers tested

for radiation in their factories show none being shipped that has any indication of excessive radiation—or any likelihood of developing such. (4) There is no cause for even the mild alarm that keeps flaring up.

The Public Health Service, the Department of Health, Education, and Welfare, a consumer-testing organization, and certain self-appointed guardians of the public “welfare” come along with their own versions—at least as reported by the press. (1) An x-radiation survey of 100 receivers belonging to PHS employees suggests that 10% or more color sets radiate above the 0.5 mR/hr acceptable limit. (2) Poorly trained or careless service technicians can inadvertently create an x-radiation boobytrap by not adjusting the color receiver correctly. (3) Line voltage that is too high can increase x-radiation beyond the limits. (4) Legislation is needed to protect viewers.

In the middle, between the two sides, is the public—the viewers. With publicity on the rise, sooner or later the innocent bystanders are going to demand explanations. The key questions are: (1) Do color sets radiate x-rays, how much, and where? (2) Are those x-rays capable of any harm to humans? (3) What has been done to overcome the danger, if indeed there is any?

Right now, the x-ray situation remains in flux. Even with the first report on receiver tests conducted by PHS in Pinellas County, Florida, no real answers seem forthcoming. Both sides can't even agree on the weapons they're using: a new PHS geiger-counter type instrument as against the industry's “standard” Victoreen unit. A standard method of measurement seems like one place to start in determining whom to believe. Certainly, when the dust settles, and before the sheriff (Congress, probably) starts making new rules, the final solution should be based on something more substantial than just who headed off whom at the credibility gap.

Wired or Wireless TV?

A complete changeover from aired TV broadcasts to cable systems throughout the country was suggested by the *ad hoc* Land Mobile Advisory Committee in its report to the FCC. The relinquished spectrum space would ostensibly be taken over by the mobile two-way radio services.

Such an idea isn't all fantasy, either. In a speech to the Association of Electronic Manufacturers (AEM) a New York consultant opined that a move like this might be forced by spectrum crowding. The CATV people would like to see it, subscription-TV advocates like the idea, and of course so do land-mobile users. There's a strong case being put together in Washington, favoring the wired-TV idea.

Still, it hardly seems necessary. Even presuming a real need for all that spectrum space by two-way and other radio services, there are so many alternatives. Satellite TV awaits the resolution of technical problems. The u.h.f. band is still largely unused.

Whether good or bad, the wired-TV idea is getting a lot of attention suddenly. The National Association of Broadcasters (NAB) is taking the threat seriously. The National Cable Television Association (NCTA) is eyeing the situation quietly. The voice of the public is yet to be heard on this topic. The next few years could see some radical changes in how we receive TV.

Place in the Sun for CB?

Citizens Band radio still suffers the pangs of being treated as the illegitimate child of the communications business. Ignored completely by its cousins—commercial two-way radio and amateur communications—this once-booming industry still commands respect when you add up a few statistics. There are between 7 and 10 million units in use; no one seems to know for sure. If unlicensed (Part 15) walkie-talkies were included, the total might be doubled or tripled. Sales run about 3 million sets a year. The FCC granted around 225,000 class-D licenses last year.

Biggest disillusionment with class-D Citizen Band has been the congestion that blocks so many would-be users from having any real chance at communication. Right now, three things are responsible for most congestion: uncaring and thoughtless hobbyists who use their (often illegally souped up) transmitters for pointless gabbing; the proliferation of 100-mW transceivers which, although weak, do jam the band; and that freak of nature, sunspots, which are permitting skip reception that blocks use in some sections of the country for hours or days at a time.

The first is a problem of regulation and enforcement, the excruciating burden of the FCC. They're working on it, and within the next year or two the Commission hopes its tougher treatment of violators will dampen enthusiasm among channel-hoggers. Limiting Part 15 transceivers to certain channels is one way to free others for usefulness; most of these low-power units are used by children as toys, anyway. The third problem, no one can help. But there is relief in sight. The sunspot cycle is expected to peak within the next couple or three months; and in another year or so it should diminish enough to quit disrupting communications. Maybe in a couple of years, Citizens Band will assume a more important place in the scheme of American communications. ▲

"King of the hill"

Keep on top of your solid-state replacements... with RCA "Top-Of-The-Line" SK-Series. They make up just a handful of types—23 transistors, 6 rectifiers, and 2 integrated circuits. Together these 31 RCA SK-Series types can keep you ahead of 10,000 solid-state replacements in entertainment-type equipment. Designed especially for this purpose, you'll find these devices useful in line-operated and battery-operated radios, phonographs, tape recorders, TV receivers, AF amplifiers, automobile radios, and stereo.

RCA SK-Series transistors and rectifiers and the 10,000 types they replace are cross-referenced in the RCA Solid-State Replacement Guide. It's a handy booklet listing comparably-rated types including industry standard EIA types, foreign types, and those identified only by device manufacturers' or equipment manufacturers' parts numbers.

Check with your RCA Distributor. He stocks the complete line in either cartons or see-through display packs. Also, pick-up your copy of the RCA Replacement Guide SPD-202-E available through your RCA Distributor. RCA Electronic Components, Harrison, N. J. 07029



RCA





**Power
Supply
Users**

TM

HOW WOULD YOU:

- ... Evaluate the effects of environmental change on a regulated current?
- ... Program a voltage inversely?
- ... Control very small currents ?
- ... Measure dynamic output impedance?
- ... Provide variable voltage limiting?
- ... Connect a feedback signal to a power supply from a temperature sensor? ... From a photo electric cell?
- ... Determine programming speed?
- ... Calculate the effect of duty cycle loading?
- ... Convert a source to a sink?
- ... Make a voltage corrector?
- ... Determine the effect of offset voltage and offset current on a power supply's output?
- ... Write the operational equation that controls feedback power supply behavior?

These are the kinds of questions answered by the 160 page *Power Supply Handbook* published by Kepco, Inc.

This book, now in its fourth printing, takes a close look at the complexities of regulated power supplies and describes their behavior and characteristics in clear, consistent terms using readily understood, simple mathematics and profuse illustrations.

Of course, if you have a power supply project in mind, we'll be glad to discuss it with you personally.



For your personal copy of this handy Handbook, write on your company letterhead to:



**Dept. J-25
G.P.O. BOX 67
FLUSHING, N.Y. 11352**

CIRCLE NO. 198 ON READER SERVICE CARD
16

LETTERS FROM OUR READERS

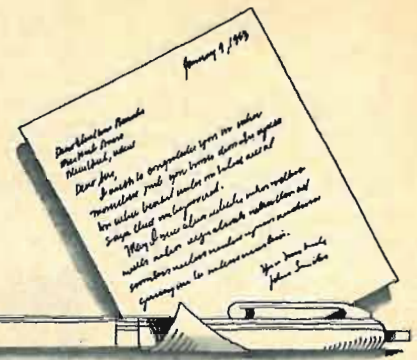

RADIATION AND THE TECHNICIAN

To the Editors:

John Frye is to be congratulated on his timely and informative article "Radiation and the Technician" (November, 1967, p. 52). However, the article is a little confusing with respect to some of the units mentioned.

The *roentgen* is a unit of exposure, the *rad* is a unit of absorbed dose, and the *rem* is a measure of the biological damage done by the absorbed dose.

The *roentgen* is defined as producing 1.61×10^{12} ion pairs per gram of air, which is equivalent to 87 ergs per gram of air. Tissue exposed to one *roentgen* will absorb a dose of 93 ergs per gram.

The term "relative biological effectiveness" (RBE) is no longer recommended in radiation protection and is reserved for radiobiology only. It has been replaced by the term "quality factor" (QF). For internal exposure the recommended QF for *alpha* radiation is 10, not 20. Externally, of course, it does not apply since *alpha* particles are unable to penetrate the outer dead layer of the skin.

The *curie* is defined as that quantity of radioactive material which decays at the rate of 3.7×10^{10} disintegrations per second, not 3700×10^{10} .

With respect to diagnostic x-ray exposures, it should have been pointed out that although a mass radiography unit chest x-ray does represent an exposure of 1-3 R, for a hospital chest x-ray it is only about 20-30 mR.

Finally, I am sure that ORNL did not "prove conclusively that lower dosages result in better pictures." I suspect that what was meant was that better pictures can be obtained, which at the same time result in lower doses (presumably by using a higher voltage with better resolution and shorter exposure times).

J. U. BURNHAM
Hydro-Electric Power Commission of
Ontario
NPD G.S. Rolphton
Ontario, Canada

Thanks to Reader Burnham for setting us straight on some of the latest terms and for correcting our omission

of a decimal point. Author Frye, in answer to some of the other comments, has the following to say:

"Most of our other differences are semantic. For example, I quote the Oak Ridge National Laboratory as saying lower dosages result in better x-ray pictures. You say higher voltage and shorter exposure will probably result in better pictures, and at the same time in lower doses. (Emphasis mine.) That is pretty much the same thing, isn't it?"

"I used the 1-3 R figure you admit to be correct for mass radiography chest x-ray units. I did this deliberately because I believe when a grave danger is being pointed out you don't use the least dangerous example. Dr. Karl Z. Morgan of the ORNL estimates the national average dosage of hospital chest x-rays in the U. S. to be 200 mR, instead of 20-30 mR. He also suggests anywhere from 3500 to 30,000 U. S. deaths may result each year from the cumulative effects of radiation.

"If my article and this correspondence help save just one of those lives, I'll be content."—Editors ▲

* * *

ELECTRONIC ORGAN KITS

To the Editors:

I enjoyed reading the article on electronic organ kits in the January issue, but I would like to point out an error or two. First, the photo on page 54 shows the *Schober Theatre Organ*, not the *Recital*. Second, in the third paragraph from the last on page 53, you seem to suggest that harmonica, saxophone, clarinet, and accordion tones are sine waves. The fact is that these are all reeds and reeds generally produce the sounds with the greatest emphasis on harmonics—about the farthest you can get from sine waves, as evidenced by the relatively harsh and blatant timbres. Actually, no real instrument produces sine-wave tones. The flutes are closest, but they definitely have harmonics.

Finally, it is not an advantage of individual-oscillator organs that the higher octaves can be tuned high and the lower octaves low as in a piano (this is known as "stretching"). Stretching is never done on any instrument but a

piano. And even a nonmusician *can* tell the difference between a stretched piano and one tuned precisely. The "correct" tuning sounds dull and uninteresting by comparison. It even sounds out of tune because the harmonics of a struck string are sharp (slightly above the frequency) of exact multiples of the fundamental, and the upper octaves *must* be tuned slightly sharp to accord with the sharp harmonics of the lower octaves.

RICHARD H. DORF, President
The Schober Organ Corporation
New York, N. Y.

* * *

KUDOS FOR A MANUFACTURER

To the Editors:

On the basis of advertising in your magazine, I ordered a "Mark Ten" capacitive-discharge ignition kit from *Delta Products* for my 1968 Volvo.

Instead of filling the order, *Delta* replied that I would encounter some unanticipated problems in installation due to the "theft-proof" armored cable which Volvo uses, and inquired if I still wanted the order filled. They could just as easily have shipped the order and dumped this problem in my lap.

On the assumption that the company applies the same high standards of business to their manufacturing as they do to their order-filling, I believe they should be publicly commended.

EDWARD M. ROBERTS
Glen Head, N.Y.

We never fail to hear about the complaints that our readers have, but it's unusual and gratifying to hear about cases like the above.—Editors

* * *

CANADIAN MARINE SSB

To the Editors:

There was a letter in the "Letters from Our Readers" column for December from R. C. Eldridge of Vancouver, B. C. in which he claimed that my statement (in the September RTCM article) that Canada had "already implemented" a change-over to SSB in the 2- to 3-MHz marine band was not so.

I quote from the Canadian Proposals to the ITU World Administrative Radio Conference as presented to the May RTCM Assembly by Mr. A. G. E. Argue (Superintendent, Radio Authorization and Enforcement, Department of Transport): "In 1961 Canada instituted a program to implement single sideband in the 2- and 4-MHz bands at Canadian coast stations, and this plan is now expected to be completed in 1969."

Since this program, according to Mr. Argue, is *to be completed in 1969*, it's fairly obvious that Canada is much farther along than Mr. Eldridge suggests.

RICHARD HUMPHREY
Staten Island, N.Y. ▲



JOHNSON'S BEST SALESMAN!

Johnson CB transceivers speak for themselves! What they say can mean a lot to the CB enthusiast who wants unmatched performance and reliability!

All Johnson transceivers

- Have built-in audio compression and outstanding transmitter efficiency for clear, distinct *Talk Power* without splatter or distortion.
- Have premium quality components throughout . . . many made by Johnson and considered the finest in the world.
- Are quality controlled during and after production . . . each and every

Johnson transceiver is "screen room" tested to insure performance that meets or exceeds Johnson's rigid standards.

- Are engineered to equal or exceed FCC and Canadian DOT specifications. All are FCC Type Accepted and DOT Approved. (where applicable).
- Are built for *solid* communications. None have meaningless features to increase cost and reduce reliability.

Johnson has manufactured more fully transistorized transceivers than all other U.S. manufacturers combined.

Stop in at your Johnson Dealer today. Meet our best salesman!



E. F. JOHNSON COMPANY

Providing nearly a half-century of communications leadership

E. F. JOHNSON COMPANY
1159 Tenth Ave. S.W., Waseca, Minn. 55093
Please send complete details on Johnson C. B. Transceivers.

Name _____
Address _____
City _____ State _____ Zip _____

CIRCLE NO. 108 ON READER SERVICE CARD



STEREO/HI-FI DIRECTORY

Giant 180 page buyers guide to virtually every new audio component on the market — amplifiers • changers and turn tables • receivers • tuners • tape machines • speakers, etc.

1968 #56

1967 #45

TAPE RECORDER ANNUAL

The only buyers guide of its kind available to the brands and models on the market. Over 132 pages of full information on over 250 models plus articles covering every aspect of tape recording.

1968 #59

1967 #42

Ziff-Davis Service Division—Dept. W • 595 Broadway, New York, N.Y. 10012
I am enclosing \$_____ for the annuals circled below. My remittance includes an additional 15¢ per copy for shipping and handling (50¢ for orders outside U.S.A.). I understand quantities are limited and orders will be filled on a first come-first served basis.

\$1.25 each

42 45 56 59

Print Name _____

Address _____

City _____

State _____

Zip _____

— PAYMENT MUST BE ENCLOSED WITH ORDER —

10 Reasons why RCA Home Training is your best investment for a rewarding career in electronics:

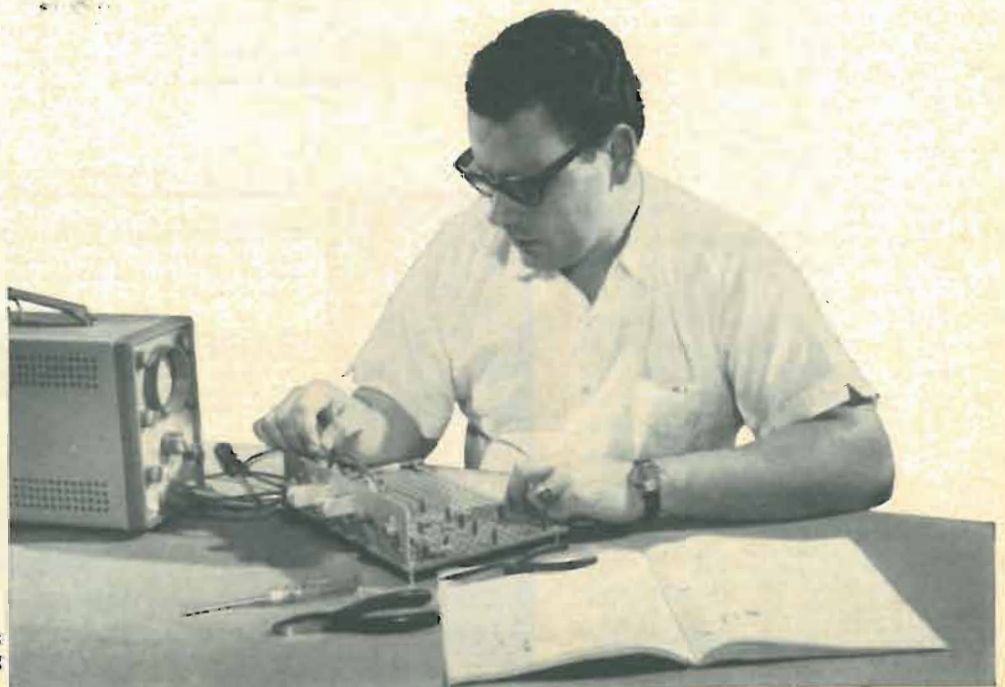

Performing transistor experiments on programmed breadboard—using oscilloscope.

1 LEADER IN ELECTRONICS TRAINING

When you think of electronics, you immediately think of RCA...a name that stands for dependability, integrity and pioneering scientific advances. For over a half century, RCA Institutes, Inc., a service of Radio Corporation of America, has been a leader in technical training.

2 RCA AUTOTEXT TEACHES ELECTRONICS FASTER, EASIER, ALMOST AUTOMATICALLY

Beginner or refresher, AUTOTEXT, RCA Institutes' own method of programmed Home Training will help you learn electronics more quickly and with less effort, even if you've had trouble with conventional learning methods in the past.

3 THOUSANDS OF WELL PAID JOBS ARE NOW OPEN TO MEN SKILLED IN ELECTRONICS

RCA Institutes is doing something positive to help men with an interest in electronics to qualify for rewarding jobs in this fascinating field. Every year, literally thousands of high paying jobs in electronics go unfilled just because not enough men take the opportunity to train themselves for these openings.

4 WIDE CHOICE OF CAREER PROGRAMS

Start today on the electronics career of your choice. On the attached card is a list of "Career Programs", each of which starts with the amazing AUTOTEXT method of programmed instruction. Look the list over, pick the one best suited to you and check it off on the card.

5 SPECIALIZED ADVANCED TRAINING

For those already working in electronics or with previous training, RCA Institutes offers advanced courses. You can start on a higher level without wasting time on work you already know.

6 PERSONAL SUPERVISION THROUGHOUT

All during your program of home study, your training is supervised by RCA Institutes experts who become personally involved in your efforts and help you over any "rough spots" that may develop.

7 VARIETY OF KITS YOURS TO KEEP

To give practical application to your studies, a variety of valuable RCA Institutes engineered kits are included in your program. Each kit is complete in itself. You never have to take apart one piece to build another. At no extra cost, they're yours to keep and use on the job.

8 FROM RCA INSTITUTES ONLY - TRANSISTORIZED TV KIT, VALUABLE OSCILLOSCOPE

Those enrolled in RCA's television course or program receive complete transistorized TV Kit. All students receive a valuable oscilloscope—both at no extra cost and only from RCA Institutes.

9 UNIQUE TUITION PLAN

With RCA Home Training, you progress at the pace that is best for you! You only pay for lessons as you order them. You don't sign a long-term contract. There's no large down-payment to lose if you decide not to continue. You're never badgered for monthly

bills. Even if you decide to interrupt your training at any time, you don't pay a single cent more.

10 RCA INSTITUTES GRADUATES GET TOP RECOGNITION

Thousands of graduates of RCA Institutes are now working for leaders in the electronics field; many others have their own profitable businesses. This record is proof of the high quality of RCA Institutes' training.

CLASSROOM TRAINING ALSO AVAILABLE

If you prefer, you can attend classes at RCA Institutes Resident School, one of the largest of its kind in New York City. Coeducational classroom and laboratory training, day and evening sessions, start four times a year. Simply check "Classroom Training" on the attached card for full information.

JOB PLACEMENT SERVICE, TOO!

Companies like IBM, Bell Telephone Labs, GE, RCA, Xerox, Honeywell, Grumman, Westinghouse, and major Radio and TV Networks have regularly employed graduates through RCA Institutes' own placement service.

SEND ATTACHED POSTAGE PAID CARD TODAY! FREE DESCRIPTIVE BOOK YOURS WITHOUT OBLIGATION! NO SALESMAN WILL CALL!

All RCA Institutes courses and programs are approved for veterans under the New G.I. Bill.

RCA INSTITUTES, DEPT. EW-48
320 West 31st Street,
New York, N.Y. 10001

Accredited Member National Home Study Council

RCA

Construction of Multimeter.

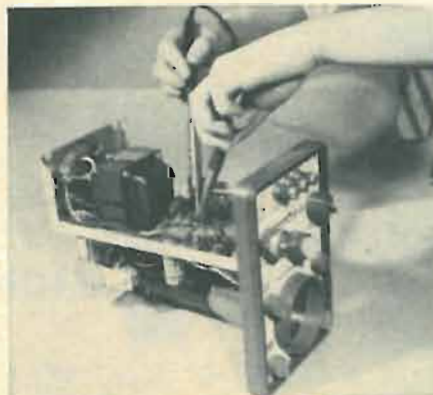

Construction of Oscilloscope.

Temperature experiment with transistors.

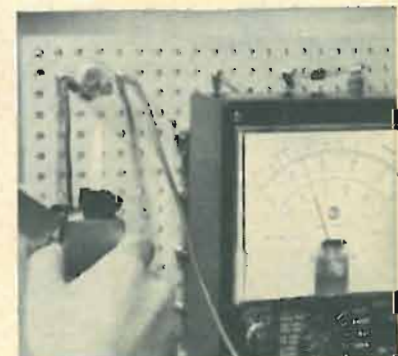

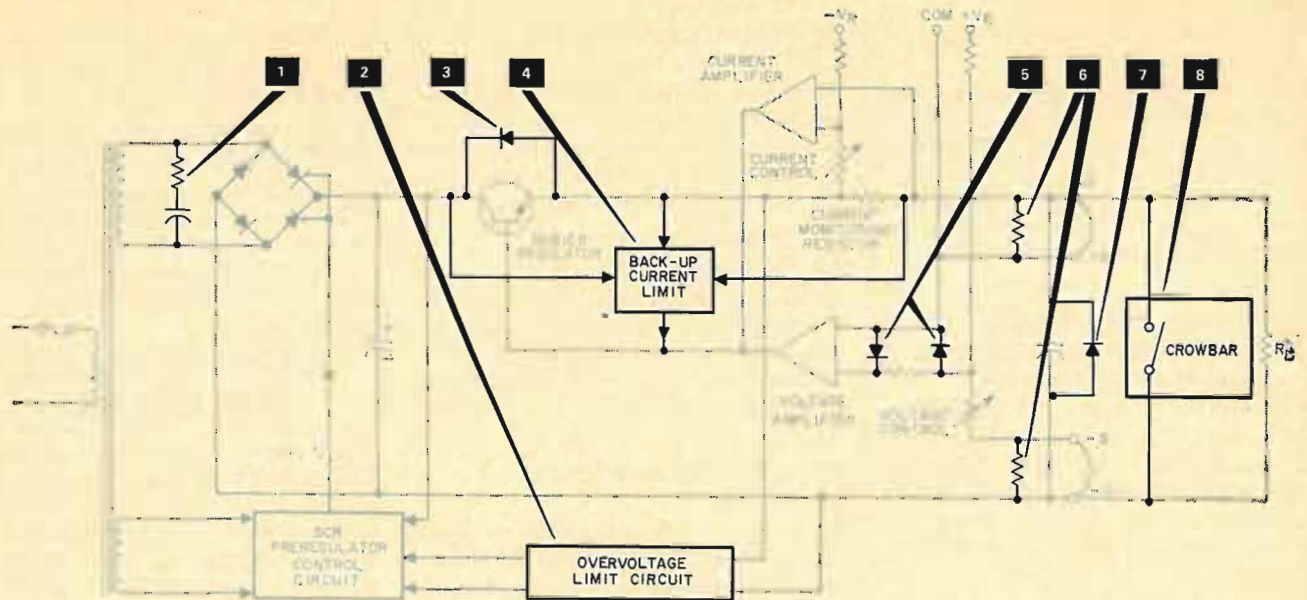

8 ways hp protects dc power supplies ... and your load

- 1.** Rectifier Damping Network . . . Protects downstream elements against short duration input line transients.
- 2.** Preregulator Overvoltage Limit . . . Protects load against excessively high output voltage.
- 3.** Series Regulator Diode . . . Protects series regulator against reverse voltage from external source (active load or parallel power supply).
- 4.** Back-up Current Limit . . . Protects load by providing back-up current limit, in case primary current limit fails or series regulator voltage becomes excessive.
- 5.** Amplifier Input Clamp Diodes . . . Protects voltage amplifier by limiting its input to less than 1 volt during violent output changes.
- 6.** Sensing Protection Resistors . . . Protects load from receiving full rectifier voltage if remote sensing leads or straps are accidentally open-circuited.
- 7.** Output Diode . . . Protects the power supply against reverse output voltage from external source (active load or series power supply).
- 8.** Crowbar Circuit* . . . Protects independently of any other power supply malfunction by providing fast clampdown of undesired overvoltage.

*Standard on some hp supplies—optional on most others

A Constant Voltage/Constant Current supply with automatic crossover inherently protects by providing adjustable current limiting in constant voltage operation and adjustable voltage limiting in constant current operation. The diagram shows eight *additional* protective features used in hp MPB-5 Series medium power bench supplies.

These protective features, in fact, are typical of those found in all hp DC power supplies. If you want to know more about the hp approach to power supply design, we'll be glad to send you our 1968 Handbook and Catalog combination. For the copy, call your local hp field representative or write Hewlett-Packard Company, 100 Locust Avenue, Berkeley Heights, New Jersey 07922; Europe: 54 Route des Acacias, 1211 Geneva 24.



HEWLETT **hp** PACKARD
POWER SUPPLIES

CIRCLE NO. 200 ON READER SERVICE CARD

Reflections on the news

By WALTER H. BUCHSBAUM/Contributing Editor

Medical Monitor

With the rapidly increasing use of electronic instruments in the medical profession, *Tektronix* has found it worthwhile to market a new, small, solid-state oscilloscope designed specifically for hospital use. The Type 410 Physiological Monitor operates up to 12 hours on internal, rechargeable batteries and can be used by medical people who have no knowledge of electronics. Its 5-inch screen displays electrocardiogram (ECG) or electroencephalogram (EEG) waveforms or related signals selected by a rotary indicating switch while a second switch permits the choice of 25, 50, or 100 mm/s sweep speeds. All markings and scales are in terms familiar to medical people. In addition to the display, the heartbeat is also made audible through a loudspeaker and an earphone jack. The unit includes an automatic heartbeat monitoring circuit which sounds an alarm less than four seconds after a heartbeat signal is lost.

The entire monitor is about 5 inches high, 9 inches wide, and 12 inches long. It can be mounted above the patient's bed or carried from room to room. Complete with battery, the monitor costs \$825.

Probably the major application for the Physiological Monitor is in intensive-care units, where critically ill patients require constant supervision. The nursing shortage has forced almost every hospital to resort to electronics for monitoring and alarm services, especially for cardiac failure. While \$825 is not cheap for a 5-inch oscilloscope, the savings in the cost of nursing care on a 24-hour basis make this unit a very economical device. We predict that many manufacturers not presently in the medical electronics field will be entering this growing market.

Electronics for the Deaf

The Lexington School for the Deaf recently moved into a new building in Jackson Heights, New York and revealed its almost complete dependence on electronics in helping deaf children to learn to use whatever hearing they have. In addition to a \$150,000 investment in electronics equipment, the school boasts soundproof construction and an anechoic chamber with extensive audio instrumentation. A separate shop, with over \$35,000 worth of test equipment and a full-time technical staff keeps the various electronics devices in working order. A complete line of auditory test apparatus, normally found only in ear clinics, is available to measure the hearing capability of each child.

Among the unique electronics aids is an r.f. network consisting of some 15 receivers, worn by the students, and a transmitter for the teacher. Made by *Electronics Features Inc.* of North Haven, Conn., this equipment uses very low power (on a Citizens Band channel) and allows the students to move around while the teacher talks to them. Each child has a microphone as well but, at present, this only feeds into the headset to help him hear himself. In the near future the school hopes to install full 2-way facilities.

In another classroom, 10 microphones, mounted on students' desks, allow each student to talk to the rest of the class through their earphones. Since the mikes are open and have no push-to-talk controls, individual preamps and amplifiers are used to avoid cross-modulation and distortion. Each student's hearing equipment is individually adjusted for frequency response and loudness. Equipment for this 10-station intercom net was made by *Precision Acoustics Inc.*, according to a special Danish design.

The audio equipment is technically not very complex, but its use in helping children overcome their hearing handicap often requires ingenuity and innovation. This is an excellent example of how electronics technology is helping to make a better life for the handicapped.

New Computer Input Devices

The major bottleneck in data processing and computing operations is still the human operator who must convert hand or typewritten data into punched cards or punched tape. These are read electronically and converted into machine language for actual use by the computer. Two new input devices promise to speed up the process of getting data into the computer.

Motorola's MDR 1000 reader is the size of a portable typewriter and can read either punched cards or cards marked with an ordinary pencil, or a combination of both, fed in singly or in batches up to 500. It can also read pencil-marked documents of standard 8½ x 11 inch size. An advanced optical reading system, combined with solid-state logic circuits, form the heart of this new device. A variety of output codes and data rates is available to make it compatible with practically any make and model computer. Depend-

ing on specifications as to codes, data rates, and input format, the MDR 1000 sells for \$1950 to \$2650.

To bridge the gap between punched cards or tape and the magnetic tape, *Honeywell* recently introduced the first direct keyboard-to-tape device, called the "Keytape". This unit permits the operator to enter data directly on the magnetic tape, in the actual computer language.

The "Keytape" also resembles a portable typewriter on a typing table with the tape transport mounted in a separate adjacent cabinet. Four different models in each of the 7- and 9-channel series are available with such optional features as telephone transmission, mixing with automatic card or punched tape readers, etc. Prices range from \$7250 to \$13,000 depending on the optional equipment and model type.

In our opinion, the most neglected portion of the computer field is still the interface between the human who is usually the source of the data and the machine which processes it. The *Motorola* unit is a great step forward because it can handle pre-punched cards with ordinary pencil markings. The technical innovation of the *Honeywell* "Keytape" tape drive is significant too, but its application primarily affects machine operations. Human operators now enter data on cards or paper tape, which is converted by machine into magnetic data, and this machine step can be eliminated by using the "Keytape". The ultimate goal in designing the best interface between man and machine is still the voice recognition machine and, while progress has been reported, it is really still "just around the corner", and a very large corner at that.

Control without Muscles

Man communicates with his environment through his muscles, either by voice or by moving some portion of his body. To turn a knob, push a button, or even roll his eyeballs, requires interaction between innumerable nerve cells and muscle fibers. In high stress environments, ordinary body movements require extraordinary energy. In a space suit, for example, the energy required to press a button on the control panel of the space capsule may be a hundred times that required under normal conditions. In many such situations the human reaction time, plus the time required to move a limb and actuate a control, is too long for safety. For these reasons, the Air Force and NASA have been experimenting with such exotic ideas as Microswitches in the teeth, eye movement detection systems, and detecting neuron potentials through microelectronics.

One system, which is ready for flight testing, was developed for NASA by *Dunlap & Associates* of Santa Monica. It uses the muscle-action potentials (MAP) of the jaw muscles. By tightening his jaw muscles, the pilot starts a control sequence which he then follows with conventional joystick action. In comparison tests, the MAP system produced 150-millisecond reaction time, with the conventional control system requiring more than twice as long.

The skin electrodes are mounted around the face in a plastic helmet similar to that used by a skin diver. Three electrodes are positioned on the forehead, each temple, and the chin. False alarms caused by inadvertent clenchings of the teeth or tightening of the jaw muscles are locked out by the system logic.

This development brings two different thoughts to our mind. The first is that skin electrodes need a great deal of improvement, as anyone who has had a cardiogram will testify. The second thought concerns the basic problem of man's communication with a machine. Barring a breakthrough in mental telepathy, we foresee a tremendous need for voice recognition machines, if and when they become available.

Terminal Radio Stations

Present passenger planes generally provide a number of channels of music in addition to the TV or movies shown in flight. Still another feature due to be added by *Eastern Airlines* in 1968 will be the broadcast of local news and weather. *Newsrad Inc.* has been conducting tests with *Eastern* and other airlines in a novel scheme whereby local FM stations use either a 41-kHz or a 67-kHz subcarrier to broadcast the latest news and local weather on a continuous basis. A special miniature helical antenna located in the cockpit is used to pick up the pretaped broadcast. The stewardess can relay the broadcast to the passengers over one of the wired music channels or over the aircraft's p.a. system.

The news and weather programs will originate from the *United Press International* offices in New York and will be piped by leased phone lines to local *Newsrad* offices at respective airports. There, decoded control signals will indicate the particular portion of the transmission intended for each local office and only that section will be recorded. Each airport station will receive approximately 45 seconds of local weather, but all stations will receive, for retransmission purposes, a short up-to-date summary of national and international news.

While this system is intended primarily for news and weather information, perhaps local advertisements for car rentals, hotels, entertainment, and tourist attractions may be added to produce revenue for the system operators. If properly handled, the system can prove helpful to air travelers, although some may prefer the more personal sound of the pilot's voice—without the pushy commercials. ▲

Be the man who's always
first to say: "I've got
the answer right here!"



START USING THIS REMARKABLE

ELECTRONICS SLIDE RULE

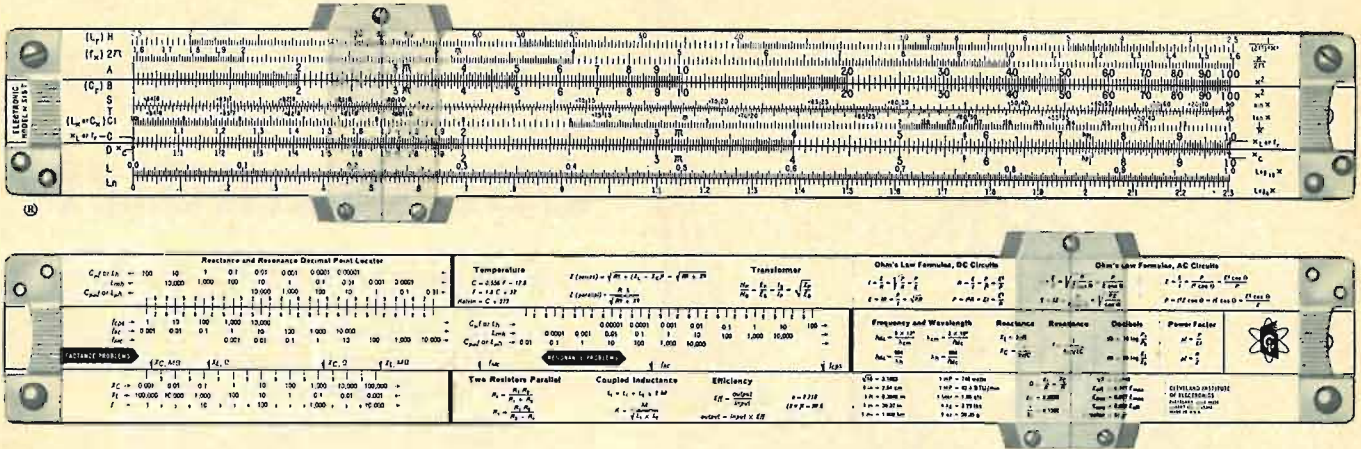

SOME DAY EVERYONE in electronics may have a slide rule like this. Till then, the man who uses one will seem like a wizard as he solves reactance and resonance problems in 12 to 20 seconds —without pencil and paper.

This is a professional slide rule in every detail, a full 10" long, made exclusively for Cleveland Institute of Electronics, to our rigid specifications, by Pickett, Inc. It can be used for conventional computation as well as special electronics calculations. All-metal construction assures smooth operation regardless of climate.

Handsome top-grain leather carrying case has heavy-duty plastic liner to protect slide rule; removable belt loop for convenient carrying. "Quick-flip" cover makes it easy to get rule in and out of case.

You also get four full-length **AUTO-PROGRAMMED™** Lessons, which teach you how to use the special electronics scales on the slide rule. These lessons have been carefully designed to meet the same high educational standards as the electronics career courses for which our school is famous. Even if you've never used a slide rule before, you'll soon whiz through the toughest problems with this CIE rule.

Deliberately underpriced. Many men in electronics have told us that this unique slide rule, leather case, and 4-lesson course easily add up to a \$50 value. But we have deliberately underpriced it at less than \$25. Why? Our reason is simple: we are looking for men in electronics who are ambitious to improve their skills...who know that this will require more training. If we can attract you with the low price of our slide rule and course—and impress you with its quality—you are more

likely to consider CIE when you decide you could use more electronics training.

Send for free booklet. See for yourself why this amazing slide rule and course have made such a big hit with busy electronics men everywhere. No obligation, of course—just an opportunity to get in on the best offer ever made to people in electronics. Just mail coupon, or write Cleveland Institute of Electronics, Dept. EW-150, 1776 East 17th St., Cleveland, Ohio 44114.

CIE Cleveland Institute of Electronics
1776 East 17th Street, Cleveland, Ohio 44114

MAIL THIS COUPON FOR **FREE BOOKLET**

Cleveland Institute of Electronics
1776 East 17th Street Cleveland, Ohio 44114
Please send me without charge or obligation your booklet describing CIE Electronics Slide Rule and Instruction Course. **ALSO FREE** if I act at once: a handy pocket-size Electronics Data Guide.



Name _____ (please print)
Address _____
City _____ State _____ Zip _____



Accredited Member National Home Study Council
A Leader in Electronics Training... Since 1934

EW-150

Circle No. 120 on Reader Service Card

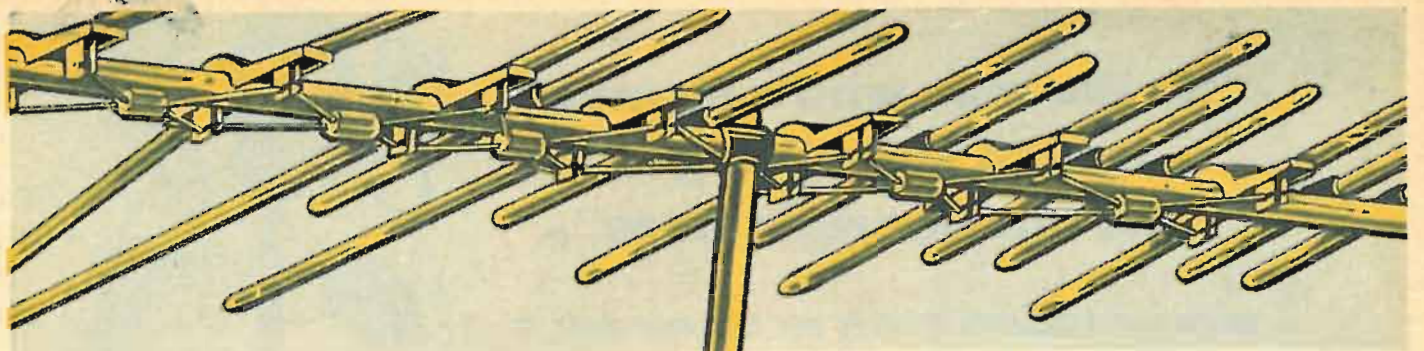

Gavin Throws Down The Gauntlet!

We hereby challenge the entire antenna industry to side-by-side comparison tests. We claim that GAVIN antennas outperform all others. Our new V-Yagi design delivers stronger signals, better pictures than any other type antenna on the market.

But anybody can make claims. We're ready to back ours with objective proof, anytime, anywhere. The proof is simple. Using our specially equipped vans, we check your favorite antenna on a field strength meter and a color receiver simultaneously. Then, we replace your antenna with a GAVIN antenna, about the same size and costing the same or less. So far, we've never lost.

If you'd like to see a side-by-side comparison test, contact your local GAVIN representative or write us a note. We'll drive the van to your door — let you make all the adjustments and set up the test yourself, if you like.

This challenge applies to all distributors, installers, and antenna manufacturers. Any takers?

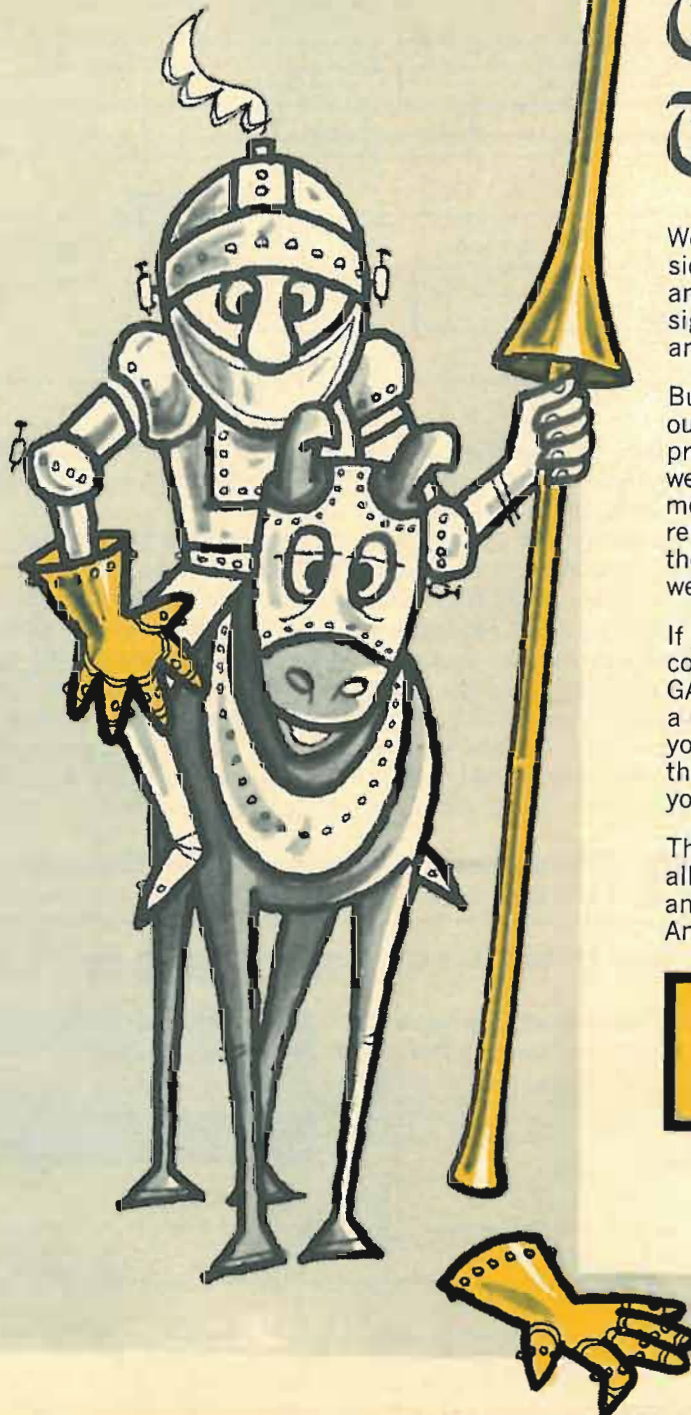

GAVIN INSTRUMENTS, INC.

Subsidiary of **ADVANCE ROSS CORP.**
Somerville, N. J. 08876 U. S. A.



THE TECHNICAL INSTITUTE GRADUATE

How does he compare?

By JOHN H. McELROY

In spite of a shortage of qualified engineers and engineering technicians, the technical institute graduate with an A.S.E.E. degree or equivalent is not being fully used. Due to lack of knowledge of the extent and depth of his training, the scientific and the professional community often undervalues such a graduate and denies itself the benefit of his ability. Here is a comparison between courses offered by a number of universities and tech institutes; results may surprise you.

Editor's Note: Our author is an electrical engineer who is currently engaged in laser research for NASA. Prior to obtaining a degree in electrical engineering, he graduated from a technical institute and worked as an electronics technician for nearly twelve years. For five of those years, he served as an instructor and technical writer on guided-missile electronics. Functioning as both a technician and engineer has given him an unusual view of the electronics industry.

A disturbing aspect of the industry that the author has observed--and with which we concur--is the profound ignorance of many engineers with regard to the training offered by the nation's technical institutes as

well as schools and colleges offering associate degree programs in electronics technology. Few engineers or engineering supervisors appreciate the technical depth of these programs. As a result, there has been in some cases gross underutilization of the skills of the technical institute graduate simply because his supervisor believed that he had received only very low level training. There is no excuse for this attitude, especially today when both our universities and technical institutes are graduating an insufficient number of trained technical people. The following article is the result of the author's and of the editor's concern about this particular situation.

THE shortage of qualified engineers and technicians needed to supply the ever-increasing demands of the electronics industry has been the subject of more speeches and articles in the last year than perhaps any other technically oriented topic. Simple business economics dictate that when a shortage exists, a careful examination should be made of how well the available supply is being utilized. This article concerns the utilization of the technical institute graduate--the graduate of a 27-month

program which leads to the awarding of a certificate or an associate degree in electrical engineering or technology. Present such programs in electronics technology, as well as two-year programs offered in some colleges and technical institutes leading to associate degrees, exhibit a depth which is often surprising to practicing engineers, other technologists, and engineering supervisors. Because of simple ignorance of the extent of his training, the scientific and professional community often undervalues the technical



Design techniques are an important part of the technical institute student's training. In this photo an instructor checks out a student-designed circuit with transistor circuit synthesizer.

institute graduate and consequently denies itself the benefits of his training.

The purpose of this article is to clarify to both technicians and engineers the way in which the training provided by a number of technical institutes compares with that given to engineering students at several representative colleges. It will be shown that the technical institute graduate compares favorably in some respects with the typical engineering graduate—in spite of the comparisons being drawn between an associate degree program normally lasting 27 months and a baccalaureate program requiring a minimum of four years.

It will be shown that, at least in the cases studied, *the technical institute graduate has had at least as many and usually more hours of instruction in his field of specialization than has the typical engineering graduate.* It will be further shown that the technical institute graduate cannot be regarded as mathematically illiterate, since *he has been exposed to nearly the same range of mathematical topics as the engineer,* although not necessarily at the same depth. The technical institute graduate's mathematical background will be shown to be more than adequate to carry him far into the theoretical aspects of his chosen field. Convincing evidence will be given to warrant a careful study of the employment of each technical institute graduate by his supervisor to ensure that his abilities are being well utilized.

Making the Comparison

For purposes of comparison, the curricula are divided into the following areas: English, other non-technical subjects, chemistry, physics, engineering fundamentals, mathematics, and electrical engineering or electronics technology. This division seemed most appropriate in order to take in the various curricular differences.

Four universities were selected for use in the comparison. Each is accredited by all appropriate authorities, including the Engineer's Council for Professional Development. They are representative of the schools which produce the majority of the electrical engineering graduates each year in the United States. Although it was inevitable that the author's personal bias would be reflected in the schools that were chosen, every effort was made to select only distinguished schools with fine reputations. The name of each would be instantly recognized by any person in the electronics industry.

Three technical institutes were chosen for the comparison. Each would certainly rank in the top 10 technical schools in the country. Like the universities, these schools

and their programs are accredited by all regional and national authorities. It will be noted that the names of the universities and technical institutes do not appear in the article. It was not the author's intention to either praise or condemn a particular school, but to indicate how representative programs compare.

Results of Comparison

The results of the comparison are shown in a series of bar graphs. These graphs show the number of semester hours that a student would take in each of the subject areas. A semester hour is approximately the equivalent of attending class for one hour each week for one fifteen-week semester. A three-semester-hour course, therefore, represents nominally 45 hours of classroom instruction. Some of the bar graphs relating to the universities are made up of both a solid and a shaded portion. The solid portion represents the number of hours required by the university as a minimum. The shaded portion is the number of additional hours that a student might elect to take in that area. It would be a rare graduate whose education contained either all or none of the shaded portions—the average program would include some elective subjects. It is not possible to be more specific because of curricular differences between schools and between individuals within the same school.

The first comparison concerns the subject of English and is shown in Fig. 1. It was surprising to find that one of the technical institutes requires more hours in this subject than any of the universities. This contrasts sharply with the view that a technical institute gives only a very narrow education. While it must be admitted that some technical institutes spend a certain amount of time on remedial work which is below university level, it is highly creditable for the technical institutes to make any sort of comparable showing at all.

The area of other non-technical subjects is shown in Fig. 2. This area includes government, history, philosophy, and other courses of a similar nature. Considering the limited amount of time available to the technical institutes, their relative weakness in this area is not unexpected. Note, however, that these subjects are not entirely neglected by two of the technical institutes.

Fig. 3 shows the next area to be discussed, chemistry. This too was a surprising area. Two of the technical institutes give no instruction in chemistry, just as expected. On the other hand, the remaining technical institute requires an amount just short of that required by the universities.

The comparison of physics programs shown in Fig. 4 is somewhat deceptive. Although the number of hours the technical institutes devote to physics is not unrespectable, a closer examination of the curricula reveals that the courses are usually conducted at a somewhat lower mathematical level. It is not unexpected, nor a criticism of the technical institutes, that they should trail the universities in this subject. Physics is one of the areas in which the engineer should quite naturally receive more and deeper instruction than the technician or technologist. This area has been one which has seen increased emphasis in recent years as the trend toward a better scientific background for the engineer has become established.

The fifth area studied, engineering fundamentals (see Fig. 5), consists of courses in engineering drawing, thermodynamics, statics, dynamics, mechanics of materials, and fluid mechanics. None of these subjects, with the single exception of engineering drawing, has been a traditional part of the training provided by the technical institute.

The subject of mathematics is covered by the sixth graph (Fig. 6). Math coverage has been the traditional demarcation between the technician and the engineer. As is shown in the graph, that boundary has been the object of a vigorous assault by the technical institutes. The technical in-

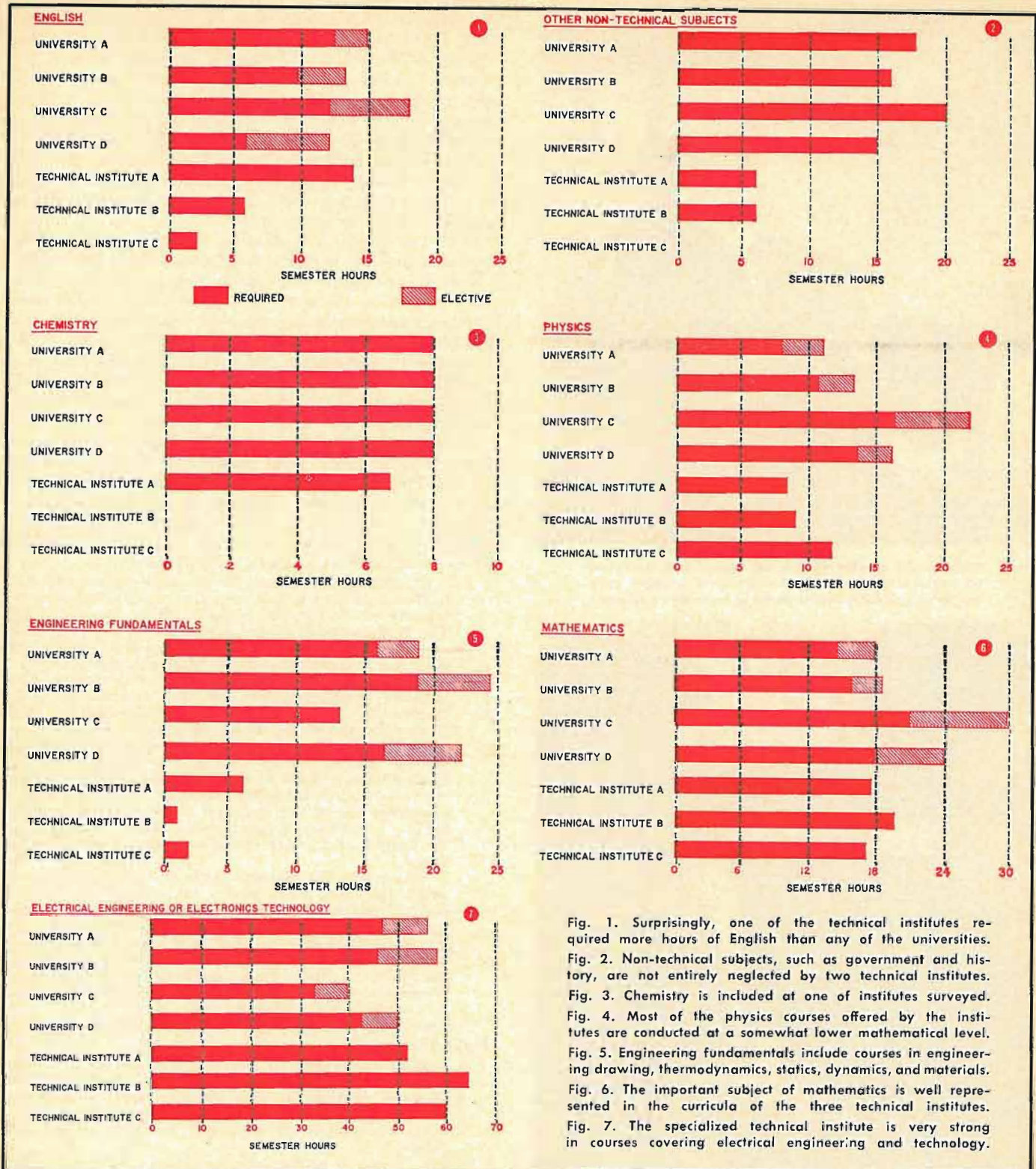

Fig. 1. Surprisingly, one of the technical institutes required more hours of English than any of the universities. Fig. 2. Non-technical subjects, such as government and history, are not entirely neglected by two technical institutes. Fig. 3. Chemistry is included at one of institutes surveyed. Fig. 4. Most of the physics courses offered by the institutes are conducted at a somewhat lower mathematical level. Fig. 5. Engineering fundamentals include courses in engineering drawing, thermodynamics, statics, dynamics, and materials. Fig. 6. The important subject of mathematics is well represented in the curricula of the three technical institutes. Fig. 7. The specialized technical institute is very strong in courses covering electrical engineering and technology.

stitute graduate of present-day programs has a striking mathematical background that cannot be easily dismissed. It is clearly seen that each of the technical institutes devotes a very substantial amount of time to this vital subject. Every technical person knows that no other subject is more important to a man's future technical growth than mathematics.

The amount of time that the technical institutes devote to mathematics does not in itself establish anything about the level attained by their graduates. When, however, it is coupled with the fact that each of the technical institutes requires training through and beyond the level of differential equations, it is indicative that their graduates

have reached a degree of competence which permits them to function at a relatively high technical level. Since all the technical institutes include training in the Laplace transform either as a part of their differential equations course or in a separate course, the whole range of modern operational techniques of circuit analysis and synthesis is open to the technologist completing these programs. The difficult transients problems which so many of us sweated over during our initial introduction to circuit analysis become simply exercises in algebra with these powerful mathematical tools.

Any engineer who carefully examines his day-to-day mathematical needs will be forced to admit that the topics

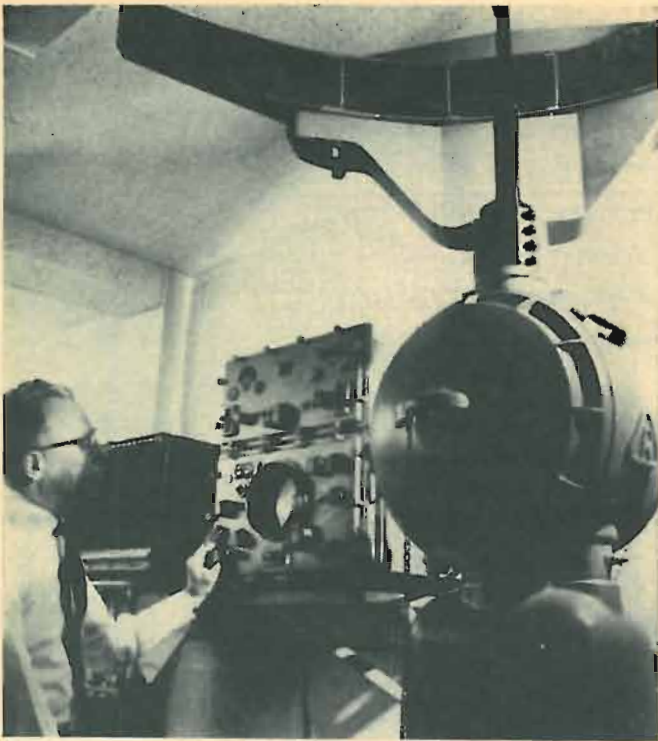

Practical side of electronics is not neglected at the technical institute. Here an instructor sets up a simulated problem in range finding for his course in microwave and radar.

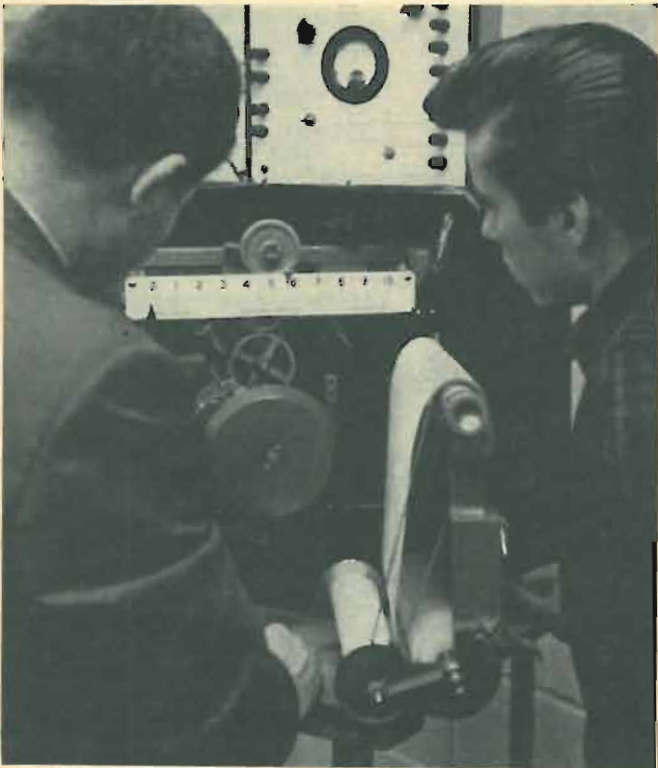

The modern technical institute student receives training in a good many fields. The student and instructor shown are engaged in temperature measurement in an instrumentation lab.

presented by the technical institutes cover the vast majority of his needs. This is not true for the research engineer probing deep into the frontiers of his profession, at least not in all cases, but it is certainly true for the average working engineer with a bachelor's degree.

Electronics Technology

The last area of comparison is the most important of all—electrical engineering or electronics technology. The

seventh graph (Fig. 7) clearly shows the results of the specialization of the curriculum of the technical institute. Each of the technical institutes surpasses each of the universities in the number of required semester hours in this subject. A closer examination of the curriculum reveals an even more surprising fact. If the total number of hours that a student actually spends under the supervision of an instructor (both classroom and laboratory) are determined, it is found that each technical institute requires more contact hours than any of the universities. In one case, a technical institute requires more than twice as many contact hours as three of the universities.

Even this impressive showing would not warrant the statement that the technical institute graduate has reached a level of training in some areas that approaches that of many engineers. However, if the individual course offerings are examined, it is seen that great similarities exist between courses covering the same subject matter at the two types of institutions. (*As a matter of fact, we know of cases where the same textbooks are used, although the course given in the technical institute is somewhat longer than that offered by the university.*—Editor)

As an illustration, two areas will be given special attention: electromagnetic field theory and automatic control systems. These two areas were chosen because they are usually considered to be more demanding than such subjects as beginning circuit theory and electronics. Consider first electromagnetic field theory. Technical Institute C provided the following course descriptions in this area:

Electromagnetic Fields: Vector analysis, an important mathematical tool in field theory, is undertaken before the subjects of electric and magnetic fields are considered. The fundamental laws and equations of these two fields are discussed with many applications given. Time-varying fields are discussed, leading to Maxwell's equations.

Lines and Antennas: The first part of this course is an analytical study of transmission lines at audio and radio frequencies, covering the general development of transmission-line theory and its special application to the transmission of r.f. power, including the use of line sections in place of lumped constants in the v.h.f. and u.h.f. ranges. Extensive use is made of the Smith chart in the graphical solution of transmission-line problems. The second part is a continuation of the analytical study of electromagnetic fields . . . with the application of Maxwell's equations in the analysis and design of transmitting and receiving antennas.

Microwaves: An analytical study of the components used in that portion of the frequency spectrum assigned to u.h.f. and microwave applications. Beginning with u.h.f. tube types and transmission-line oscillators and amplifiers, the course continues with the analysis of microwave tubes employing the velocity modulation principle. . . . Maxwell's equations are applied in the mathematical analysis of the rectangular waveguide and in the discussion of the circular waveguide and cavity resonator.

Technical Institute A gives a course entitled simply "Field Theory". Its course description reads:

Static fields, electric and magnetic; quantitative relationships; Maxwell's equations; vertical, horizontal, and elliptical polarization; elementary antennas; interference; reflection; refraction; diffraction; transmission lines: tuned, untuned, characteristic impedance, matching stubs, Smith chart.

A further course in waveguides, antennas, and propagation follows the field theory course.

Compare these course descriptions with the following received from the universities. University C administers a two-semester course entitled "Fields and Waves". It has the following course description:

An introduction to the theory of electromagnetic fields with stress on physical concepts and engineering applications. The fundamentals of electromagnetic theory in vector notation, circuit and field concepts at low and high frequencies. Maxwell's equations. Propagation and reflection of plane waves; solution of the wave equation, waveguides, cavity resonators, radiation from antennas and antenna arrays.

University D provides the following description for its course in electromagnetic theory: (*Continued on page 83*)

NEW FILTER DESIGNS

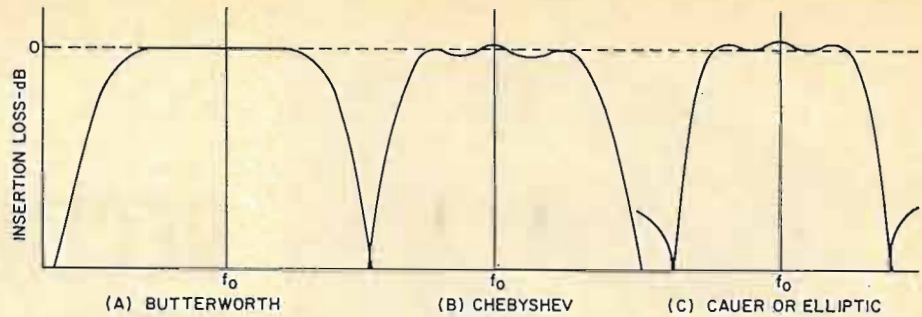

Fig. 1. Response curves of the three filters described in text.

By WILLIAM M. STUTZ/Sr. Lab Technician, T.R.G. (Div. of Control Data Corp.)

The newer filters, such as Butterworth, Chebyshev, and elliptic types, are more accurate and easier to design.

WITH the many advances being made today in the field of semiconductors, it is almost impossible to keep abreast of developments. Therefore, it is not strange to find that familiar old passive circuits have advanced too. One particular area, filters, has changed radically from what many remember from technical school and college days. The old filters, such as constant-K and M-derived types, have been replaced by the Butterworth, Chebyshev, and elliptic types. These newer designs have much to recommend them. Their responses are more accurate over a wide range and are easier to design. (Fig. 1)

The constant-K and M-derived types were traditionally designed section by section. This method was involved since each section had to be matched while trying to optimize the response. The results of such designs were approximate to say the least. Today the filter is designed as a whole, which simplifies the matching and allows us to optimize the response. Both problems actually reduce to almost "cookbook" simplicity in most cases. The third problem in filters, realization, now becomes the main problem.

The actual mathematics involved in a filter design today is very abstract and is usually best left to the mathematicians. The filter's properties are expressed by a transfer equation that is a function of frequency. The shape of the response is then set, but actually that is all that is permanent. The frequency and impedance information contained in such a transfer equation may be extracted. The remaining information is said to be "normalized". A normalized number or quantity may then be used under a large number of circumstances as opposed to the unique value or quantity simply by supplying the missing information to de-normalize the quantity. This mathematical trick allows us to catalogue the elements of a specific filter type and to design from them a filter of any particular bandwidth or impedance value that we require.

Originally, the term "realization" meant the mathematical realization process. This requires at least a mathematician and at most a digital computer. The term now means the physical as well as mathematical processes of determining the actual *L* and *C* component values to be used. I prefer the terms "de-normalization" and "realization" to distinguish the two.

Transformers are sometimes added to the filter for impedance matching or for balance-to-unbalance conversion.

The various filter circuits can be made in two general forms. These are the *ladder* network and the *lattice* or *bridge* networks, Fig. 2. The ladder network is an unbalanced network, that is, it is a three-terminal network. This type of network is used where the input is single-ended such as for unbalanced antenna lines or single-ended r.f. or a.f. amplifiers.

The three basic filter circuits may all be built as a ladder, in fact, this is the most common configuration.

The lattice or bridge type is a balanced or four-terminal network. This makes the circuit useful only when the source is balanced with respect to ground such as in 300-ohm balanced lines or any other area where the source and load are balanced. This circuit is sometimes used with crystals to form a crystal-lattice network.

Physical capacitors and inductors are not perfect, *i.e.*, the best capacitors have some leakage and the best coils have some resistance. How, then, may a filter be made which was designed assuming ideal elements? As a rule of thumb, it has been found that the more the filter requirements tighten, the less dissipation is allowable, and the closer the elements must be to the ideal. This is related to the elements by a term called the *minimum "Q"*.

The ratio of reactance to resistance of a coil is called "Q". When this ratio is small, the coil acts as an *RL* circuit and not like an inductor. This will put a large insertion loss in the filter passband and distort the passband shape, usually at the edges first. Because of this problem we must have a certain

(Continued on page 82)

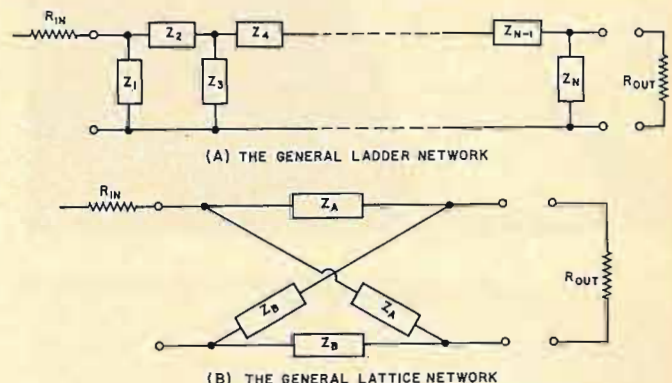

Fig. 2. (A) Unbalanced and (B) balanced arrangements.

Table 1. Unloaded minimum "Q's" for two filter types.

TYPE OF FILTER	NUMBER OF POLES					
	2	3	4	5	6	7
Butterworth	1.4	2	2.6	3.25	3.9	4.6
Chebyshev (0.1 dB ripple)	1.65	2.8	4.5	6.8	9.5	13.0
Chebyshev (0.3 dB ripple)	1.8	3.4	5.4	7.1	12.1	16.3
Chebyshev (1 dB ripple)	2.3	4.5	7.5	11.8	16.8	21.9
Chebyshev (2 dB ripple)	3.15	6.6	11.8	18.3	26.2	36.4



RECENT DEVELOPMENTS IN ELECTRONICS



Tiny Antenna-Amplifier. (Top left) The unit being held at the left is a small spiral microwave antenna which has a tunnel-diode amplifier built in. The amplifier is powered by a single flashlight battery. The antenna-amplifier is designed for use on combat aircraft where it serves as an active reflector. When a ground-based radar or other transmitter is picked up by the spiral antenna on the plane, the signal is then amplified by the tunnel diode and retransmitted back to the ground. In this way the plane is accurately identified so that high-security directions may be transmitted to the plane. Without the correct activating signal, the device is completely passive. In designing the unit for the Air Force, Sylvania engineers had to balance the negative resistance of the tunnel diode against the positive resistance of the antenna. Hence, careful control must be maintained both in the design and manufacturing of the antenna-amplifier unit.

Air-Data Computers for Jet Planes. (Center) This 23 1/2-pound universal air-data computer provides signals for use with aircraft flight instruments, automatic flight controls, and navigation equipment. Other tasks include generating information for altitude reporting and for control of cabin pressure. The computer, which is in use or on order by 46 airlines, centralizes air-data functions formerly performed by a variety of devices. Honeywell, the computer's manufacturer, recently announced a \$3.1 million order from Boeing, an order that brought total air-data computer sales to nearly \$12 million in about two years. The devices will be used on 707, 727-200, and 737 commercial jet airliners. The computer senses and measures air properties, such as pressure and temperature, and electrically derives precise flight information that is required for use by the pilot and the automatic control systems that are employed in planes.

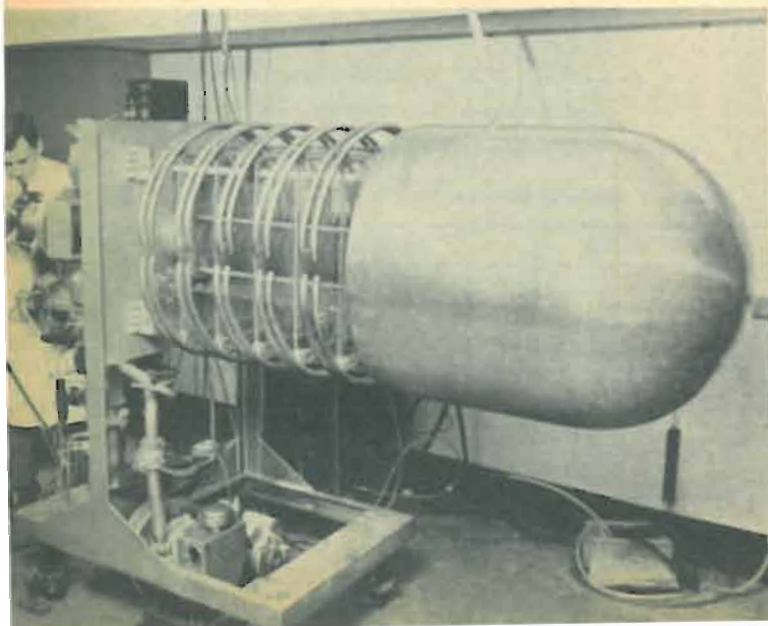

Accelerator for Cancer Research. (Bottom left) Investigation into radio-biological treatment of cancer by fast neutrons will be increased by a West German research institution that recently purchased the specialized particle accelerator shown. This 300,000-volt accelerator will assist the research center in extending to humans a fast neutron therapy program that has been used previously on animals. Since fast neutrons penetrate tissue deeply, they have been used in cancer therapy research in various parts of the world for some time. One problem, however, has been the difficulty of generating enough neutron flux for proper penetration before dissipating the radiant beam. This particular accelerator, which is designed and manufactured by Radiation Dynamics, should produce enough flux to make fast neutron therapy practical. The unit costs about \$70,000.

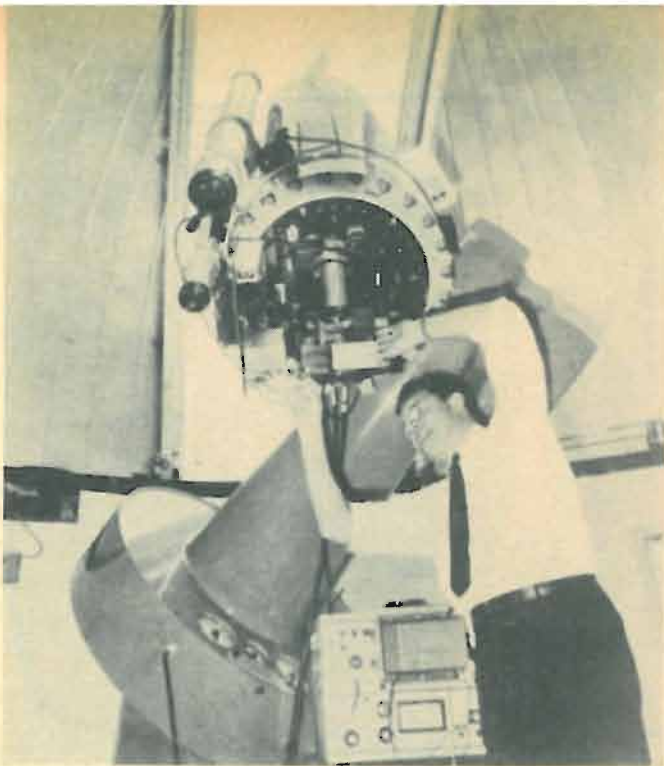

Infrared Scanner for Moon Landings. (Top left) The 24-in telescope shown is equipped with an infrared scanning system to evaluate possible Apollo landing sites. By analyzing the heating and cooling rates of lunar areas during the day-night cycle, information becomes available for planning touchdown and subsequent exploration. The IR scanner, designed by Barnes Engineering, is attached to the back of the telescope tube while associated electronics is in cabinet shown at the bottom.

Rear-Port Cathode-Ray Tube. (Top right) The 8-in CRT shown here not only produces images from a fairly conventional electron gun, but its screen can have projected on it optical images from a slide projector. Hence, it is possible to display changing radar information superimposed on a fixed background map. The map can be projected in a different color for ease of viewing. This method of producing the background is far less expensive than if the map were generated electronically. The new rear-port cathode-ray tube was designed by Ferranti Electric primarily for air traffic control use.

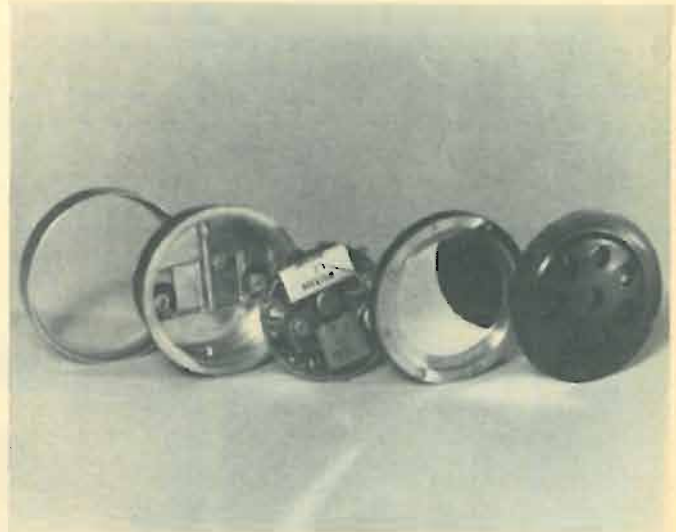

Experimental Electret Telephone Mike. (Center) This new telephone microphone combines a pre-polarized electret element with a semiconductor amplifier. Main advantage is reduction in operating current by 90%. The dielectric used to make the electret film is granular polycarbonate. The film, previously charged by a high-voltage electrostatic field, is able to hold its charge permanently just as a permanent magnet retains its field. The permanently charged film is then used to produce an electrostatic field in an air gap between a vibrating diaphragm and a rigid backplate, hence forming a capacitor microphone but without any polarizing voltage source. Although the mike can be made to produce a flat response, its output is altered by the developer, Northern Electric, to match the response of a more conventional telephone microphone.



Historical TV Tubes. (Below right) These five 40-year-old TV camera and receiver picture tubes, which are among the world's first, have just been donated to the Smithsonian Institution by their inventor, Dr. Philo T. Farnsworth. The noted scientist, now with ITT, has been called the "father of electronic television." Laboratory notebooks and other documents have also been donated by the scientist, who invented the TV camera and picture tubes in his late teens and early twenties.

Tuning in on

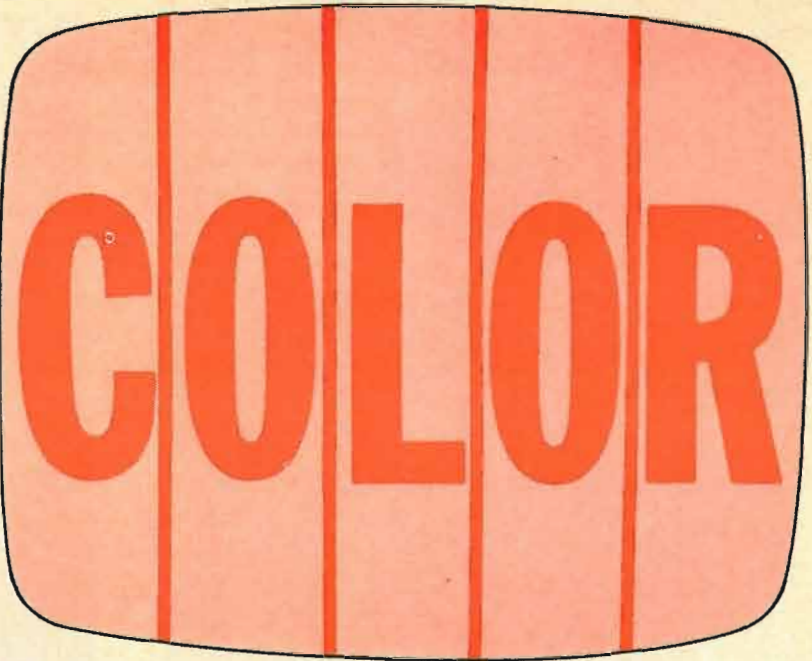

By FOREST H. BELT / Contributing Editor

Here's the right way to tune color sets along with an explanation of what the controls do. Also covered are circuits that are built in to make tuning easier.

COLOR-TV is about 15 years old and, like most teenagers, it isn't always understood by the adults who live with it. With both, there is a certain amount of adjustment to be made before they work their best. Fortunately, there are definite rules to guide the person faced with developing a working relationship with a color receiver.

Explaining these guidelines is one of the responsibilities of the service technician when he installs the color receiver. Some do the job well; others either neglect the job or are unable to make the instructions clear. When the job is done right, the owner will know the 1-2-3 procedure that pro-

duces a clear and properly hued picture—and every time.

The color tuning procedure isn't really difficult to understand. There are five controls which determine how well the color set renders color. They are: Brightness and Contrast, which also affect the black-and-white picture; Fine Tuning, which affects black-and-white but must be set much more carefully for color; and Hue (or Tint) and Color controls, both used only for color. There is a definite order in which to operate these five controls. Out of sequence, tuning in a really good color picture becomes a haphazard process. Someone with experience can do it, but for the average color-set owner it may not be so easy.



Fig. 1. (A) Severe beat interference. (B) Slight beat interference, (C) Properly tuned-in black-and-white picture.

Fig. 2. (A) Excessive brightness and contrast. (B) Insufficient brightness and contrast. (C) The proper settings.



To understand the color-tuning process thoroughly, you need to know what effect each control has on the picture, on the operation of the circuits in the set, and on one another. You should also be aware of the aids and helps built into many modern color receivers. They take several forms and represent innovative circuits. However, before we get into those, here's the correct way to tune in a color program, and some explanation of what the controls are doing to the set as you operate them.

From Black-and-White to Color

If you're starting from scratch, the best thing is to turn the Color control to minimum (counterclockwise) and the Hue or Tint control to its center. The other three controls can be set best on a black-and-white picture, without color to confuse.

Set Brightness and Contrast arbitrarily at first, so you can see a picture of some sort. Then concentrate on the first and perhaps most important of the five adjustments—Fine Tuning. This operating adjustment is critical; it is the only one of the five that so far has deserved special aids in some of the newer models, and even automatic adjustment in more expensive ones. (*The fine-tuning control actually adjusts the frequency of the receiver local oscillator. The effect is to place the received signals properly in the receiver's i.f. band-pass response curve.*—Editor)

First, though, without aids: Turn the Fine-Tuning knob toward the end of its rotation which produces clear sound but a blanked-out picture or severe sound-grain interference such as that shown in Fig. 1A. Then turn it back, almost clearing up the interference grain (Fig. 1B). Interference here is as much a 3.58-MHz beat as 4.5-MHz grain. It is at this point that the chroma signal and the color-sync burst are tuned in most strongly. But you can't view the picture comfortably with this interference in it, and besides, the video signals are not yet properly located on the receiver band-pass curve. So you turn the control just a little more to rid the picture of the grain—but no further. This is a critical adjustment; make it carefully. When it is done properly, the black-and-white picture should look smooth, as in Fig. 1C. There will be no interference and picture details will be clear.

Next, adjust the Brightness and Contrast. This must always be a compromise between too dark and too light. The usual tendency is to turn the Brightness too high, then make up for it by turning the Contrast well up. Fig. 2A shows the result—a rather garish, harsh picture. Such a picture would never look well when color is added. Rather, keep both the brightness and the contrast as low as possible without washing out the picture. Fig. 2B shows both at too-low settings. Start with them low and work up to a good range of blacks, grays, and whites. Too much brightness will wash out colors and too little contrast will even affect hues. The picture should appear soft, but with good "body". Fig. 2C shows a picture that will portray color well, when color is finally added.

Now comes the color. Turn up the Color control slowly. On most sets, it is labeled Color. On *General Electric* sets it is called Chroma Gain, and *Packard-Bell* labels it Color Gain; both more aptly describe its action. On *Motorola* sets, the label Color Intensity is used. The purpose of the control is to adjust the amplification in the chroma-signal amplifier stages, determining how much of the color signal is fed to the demodulators. On the screen, the result appears as intensifying whatever color is visible; that is, the control increases color saturation. This control should not affect the hue of any color; that is, it shouldn't make green turn blue, or anything like that. Turn it up only until you see color. You'll readjust it again after you have made the next tuning-in adjustment.

It is the job of the Hue control to make the colors what they should be. The Hue control is called Tint on about

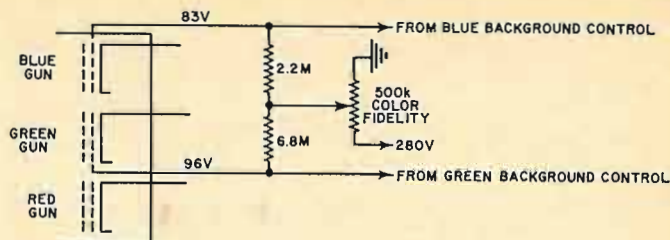

Fig. 3. Putting increased d.c. voltage on the blue and green picture-tube guns makes the picture take on a brownish color.

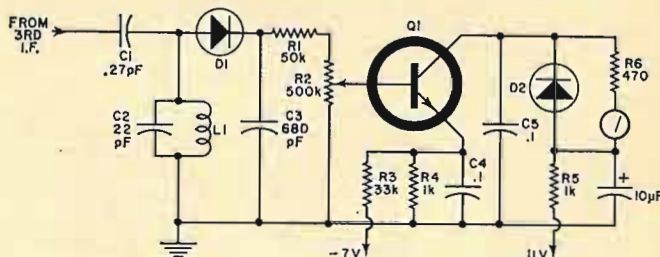

Fig. 4. Tuning meter circuit from one General Electric model.

half of the most recent models. It could be labeled Color Phase, because it varies the phase of the 3.58-MHz color subcarrier that is fed to the demodulators for recovery of the chroma signals. Its action is most noticeable in the faces of actors, since the flesh color makes a good reference. With the Color control already set for not-too-strong colors, the Hue control is adjusted for as accurate a flesh tone as you can get. Too far one way makes faces green, and too far the other makes them purple. (One caution: Certain *Motorola* models have a control called Tint which is *not* a color-phase control; on *Motorola* color sets, the color phase is adjusted with the Hue control. This unorthodox Tint control will be explained later.)

Next, readjust the Color control for a soft flesh tone, and so that other colors are not garish. Turning the Color control too high may also result in slight interference patterns in the color picture, a pattern that somewhat resembles the grain effect from incorrect fine tuning. A "dead" and faded picture is a sign that the Color control is too low.

The Color and Hue controls should show very little interaction, although the Hue control cannot be adjusted at all unless the Color control is turned up enough to put color on the screen. But, once the Hue control is set, the Color control on most models will not alter the flesh tone—just make it lighter or deeper. If the Color Gain control does affect phase, there is trouble in the set (usually an alignment problem in the chroma section) which should be cleared up.

Auxiliary Controls

On some sets there are two other operating controls which affect the color picture as well as the black-and-white. They are not basically for color reception, but like the Brightness and Contrast they must nevertheless be set properly before a decent color picture can be viewed. Both are most easily adjusted with the receiver tuned to a black-and-white picture. If a color show is on, turn the Color control all the way down to view a monochrome picture.

The first of these auxiliary controls is called a Peaking control, although it has several designations. *Clairtone* and *Magnavox* label it Sharpness, *Packard-Bell* calls it Pix Fidelity, and *Setchell Carlson* labels it Detail. One older set calls it Crispness. Most others call it Peaking, if they have it. In some, notably *Motorola*, it is a servicing adjustment rather than an operating control.

It may be a switch and it may be a control, but its purpose is to peak up the high-frequency response of the video amplifier stage and give the picture whiter sharper edges. With a monochrome picture, set the peaking control for a

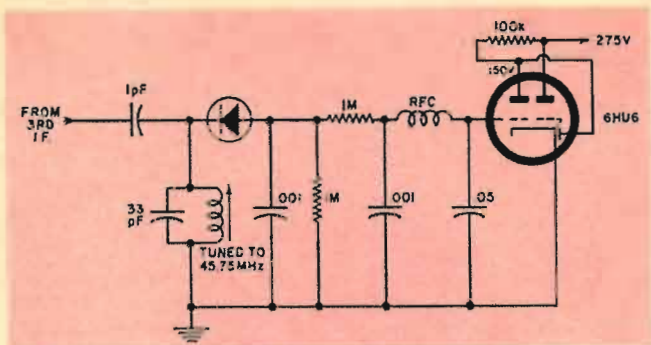

Fig. 5. Target-ray tube used as tuning indicator in a Philco.

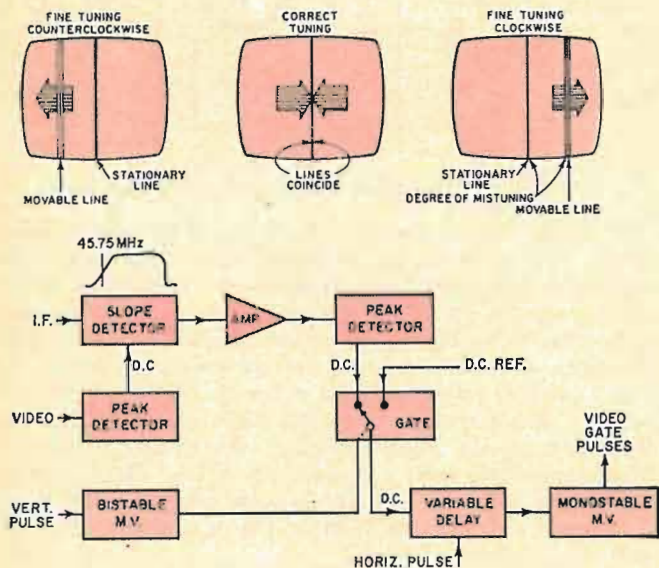

Fig. 6. Westinghouse fine-tuning indicator is probably the most complicated; uses vertical lines on picture-tube screen.

crisp picture, but don't overpeak it. Overpeaking may cause some color "bleed", particularly in the red; if so, turn it down some for a softer picture. One important point about setting this control: It is for the viewer's taste, so don't set it for a crisp picture unless the viewer wants the picture that way; some prefer softness.

The other control is a sort of "trick" control—sometimes a switch—that lets the viewer make a black-and-white picture take on a sepia or brownish hue. It does this by cutting down the blue and green and stepping up the red coloring of the raster. Before a color program can be tuned properly, this switch or control must be in the normal black-and-white position.

This control carries some undescriptive names. *Admiral* calls it Color Fidelity, and Fig. 3 shows how it is wired in the CRT circuit. Most others are wired similarly, although a switch may be used instead of a control. Other designations include *Clairtone's* Colorfast, *Hoffman's* Cinema, and *Magnavox's* Chromatone. This is the control that recent *Motorola* models call Tint instead of using that label for the Hue control.

With these two auxiliary controls in mind, let's review the sequence of tuning in a color picture. First, the Fine Tuning is set for a clear monochrome picture, as near the "sound" end as possible. Then, Brightness and Contrast are adjusted for a soft but clear picture with good grays and blacks. If the set has them, the peaking and brown-shading controls are set for a picture that is sharp and black-and-white. Finally, the color is turned up enough to permit adjusting the Hue control for a good flesh tone, and then the Color control is reset for a picture that shows a good range of color intensity without being gaudy or showing interference patterns.

Of all the operating controls that have to be adjusted to produce an acceptable color picture, experience has shown that the Fine Tuning is the one least likely to be set correctly by the average color-TV viewer. And yet, a wrong setting may prevent color reception altogether. So many of this year's models include one circuit or another to make fine tuning easier. In some sets, they are mere aids; in others, automatic circuits take over and do an accurate job if the receiver is tuned even near a proper setting.

Aids to Fine Tuning

One of the simplest aids to use, at least for many viewers, is a tuning meter. An example is the one used with the *General Electric* KD chassis. The user merely sets the channel selector to the desired channel and then fine-tunes for a maximum indication on the meter. A diagram of the *G-E* system is shown in Fig. 4.

All of the fine-tuning aids and automatic circuits use the same basic principle: tuning the receiver oscillator so that a precise 45.75-MHz video i.f. signal is produced. A very small capacitor, C1 in Fig. 4, couples a sample signal from the third i.f. stage to a 45.75-MHz tuned circuit, C2-L1. Diode D1 rectifies the sample signal, and R2 feeds a certain amount of the resulting d.c. to the base of Q1, a d.c. amplifier. Conduction of Q1 determines how much current flows in the meter, which is in the collector circuit. As the fine-tuning control moves through the "best" 45.75-MHz point, the signal developed across tuned circuit C2-L1 goes through a peak. The resulting maximum of d.c. developed by D1 is passed on to Q1 and the meter registers a collector current peak. C3, C4, and C5 help keep the video signal from reaching the meter and making it "wiggle" with changes in scene brightness. Diode D2 damps the meter, making it easy for the viewer to see a true peak.

Philco and *Andrea* use a system that is similar, except that a tuning-bar tube is used instead of a meter. The *Philco* circuit is shown in Fig. 5. Again, a tuned circuit senses when the most 45.75-MHz signal is being produced by the tuner. The signal is rectified and filtered and the resulting d.c. applied to an indicator—in this case, a 6HU6 shadow-bar tube. A dark "bar" appears against a lighter background and it becomes narrowest when the most d.c. voltage is applied to its input or control grid. Since maximum d.c. is developed when the oscillator fine tuning is permitting the most 45.75-MHz signal, the narrowest bar indicates optimum fine tuning.

Motorola uses a slightly different form of indication, although the principle of producing it is the same. Instead of indicating when fine tuning is correct, the *Motorola* system causes a lamp to glow when tuning is incorrect. A 45.75-MHz tuned circuit and a transistor work exactly as with the *G-E* system already described. The d.c. "peak" is coupled, instead of to a meter, to a switching transistor that extinguishes a lamp when the set is fine-tuned for maximum 45.75-MHz i.f. signal. If the tuner drifts, the lamp lights, signaling the viewer that the fine tuning needs touching up if a proper color signal is to be received.

Westinghouse uses a still different form of indication for its fine-tuning indicator. The viewer can pull a switch and a vertical bar (or two) appears on the screen. If two bars appear, it is an indication that the set must be fine tuned. When the two coincide, the 45.75-MHz signal is at its peak in the i.f. strip, which means the fine tuning is correct.

Producing the *Westinghouse* indicator pattern is more complicated than any of the others. Fig. 6 will help you understand how it is done. One of the vertical lines, the stationary one, is produced by "marking" the midpoint of each line during one vertical field; thus, 262 of the raster lines carry the video pip that produces the stationary vertical line which serves as the tuning reference. Its position on the screen is determined by a fixed d.c. reference voltage.

The movable tuning line is the (Continued on page 64)

The author received his B.E.E. from City College of New York in 1957. He joined Lambda in 1963 as Senior Engineer in the Advanced Development Group, where he was engaged in research on high-powered SCR switching systems, high-stability, low-power circuitry, and studies in FET applications. Later he designed low- and high-voltage series pass regulated power supplies and was in charge of supplying application information and quotations for non-standard requirements. He was formerly Manager of Instrument Products.



Power-Supply Principles and Parameters

By EDWARD S. BRENNER/Director of Engineering
Lambda Electronics Corp.

To make an intelligent selection from the large variety of available supplies, the user must know the operation and the most important specifications that are covered here.

POWER SUPPLIES and power regulators can be represented by a wide assortment of devices ranging from batteries and generators to dynamic electronic units using feedback. These include a large family of electronic converters: a.c. to a.c., d.c. to d.c., d.c. to a.c., and a.c. to d.c. Here we will be concerned with the a.c. to d.c. converter employing a series regulator.

Power-distribution systems usually use a.c. power because this power is easily generated and distributed. However, most system applications of power require d.c. power sources to energize the electronic circuitry. The specific function of the power supply is to provide substantially constant, ripple-free d.c. voltage and current from a primary source which is a.c.

Power conversion generally starts with rectification, a process which converts a.c. voltage to d.c. voltage. Because the output of a rectifier contains a relatively large a.c. ripple component in addition to its d.c. value, a filter must be used to attenuate the ripple component before this d.c. power is applied to the load. Figs. 1A and 1B illustrate two filtering configurations while Fig. 1C shows the effects of these networks.

The amount of ripple present after filtering the rectifier output is a function of the components used and the load current. No matter how efficiently ripple is reduced, the rectifier-filter d.c. output can change substantially with load current and/or power-line variations. Control of these variations is defined as power-supply regulation.

The demand for better regulation imposed by today's sophisticated circuits and complex systems can be met more effectively by the regulated or feedback-controlled power supply. Regulated power supplies are capable of maintaining a substantially constant output voltage at some selected value, even though changes occur in the a.c. supply voltage (within specified limits) and/or in the rated d.c. load current. In addition, these power sources can be made short-circuit-proof, preventing damage to the supply caused by the load, and can be made load-protecting by utilizing overvoltage protectors, which prevent load damage caused by internal supply failures.

The greatest demand for power supplies is in low-voltage

(less than 100 volts) semiconductor applications, creating a market exceeding \$100 million. The power supplies for this market are generally all-solid-state designs with more recent models using silicon semiconductors for high reliability and greater power-handling capacity per unit volume.

Power-supply packaging is dictated more by function than by appearance. Modular or system-type power supplies are available for various mounting configurations. Multiple-output power-supply systems can be assembled using modular power supplies and metered panels in rack adapters.

Some supplies can be used for either laboratory or system applications. When used in electronic systems, the rubber feet can be removed and a rack adapter provided for convenient mounting (as shown in photo on page 39). High-powered, full-rack regulators can be supplied with

Fig. 1. Rectifier and filter configurations showing (A) capacitor and (B) LC filters. (C) D.c. output voltage waveforms for single-phase, full-wave rectifier with (1) no filter, (2) capacitor filter, and (3) LC filter.

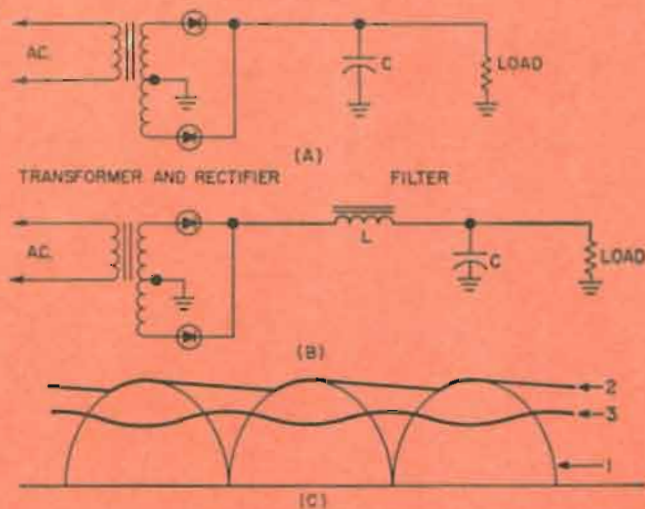

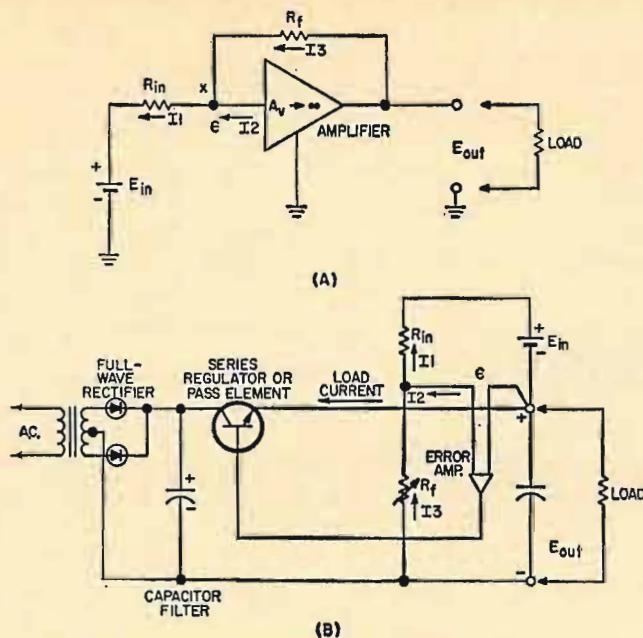

Fig. 2. (A) Operational amplifier. (B) Regulated supply.

rubber feet that are suited for laboratory and bench use.

In most cases, the user will find the power supply he requires from some manufacturer's "off-the-shelf" catalogue. To the user, this means that the device is readily available as a standard product with minimum delivery-time lapse. Standard product lines include supplies with ratings from the milliwatt range to units with ratings exceeding 10 kW. The price may be well under \$100 or well over \$5000, depending upon the power capacity and performance characteristics required.

Operating Principles

The series-regulated power supply belongs to a family of circuits referred to as d.c. operational amplifiers. These are extremely high-gain amplifiers that use feedback to control their output function and are capable of operating from d.c. to some finite limit in frequency. We will mainly concern ourselves with d.c. operation. See Fig. 2A.

The open-loop gain of the amplifier (A_v) is very large and assumed to be near infinity compared to the closed-loop gain or gain with feedback. Values of A_v on the order of 100,000 are not uncommon. In order to generate an output signal of magnitude E_{out} , an input or error voltage (ϵ) of E_{out}/A_v is required. Since A_v is many orders of magnitude larger than E_{out} , the error voltage can be considered to be zero. Using this approximation, we can then state that $I_1 = E_{in}/R_{in}$ and $I_3 = E_{out}/R_f$ because ϵ is at zero or virtual ground. Also, knowing that currents entering a node must equal currents leaving a node, we can sum the currents around node X and obtain $I_1 = I_2 + I_3$. Generally, a system must be designed with I_2 many times smaller than either I_1 or I_3 , so that essentially $I_1 = I_3$. Consequently, $E_{out}/R_f \approx I_1$, and $E_{out}/E_{in} = I_1 R_f / I_1 R_{in} = R_f / R_{in}$ is closed-loop gain. Hence, closed-loop gain is a function of external components R_f and R_{in} , as long as A_v is much larger than R_f / R_{in} and I_1 is much larger than I_2 .

We now rearrange Fig. 2A to satisfy the circuit requirements of the series-regulated power supply, shown in Fig. 2B. Although this is basically a model of a power supply which can be operated over a wide voltage range starting from zero volts (zero supply), the theory is applicable to narrow-range (slot) supplies.

In the power supply, the error amplifier and pass element together are equivalent to the entire operational amplifier of Fig. 2A. A full-wave rectifier and a capacitor filter provide "B+" voltage for the pass element. The error

amplifier is normally powered by an auxiliary bias supply. The input voltage, E_{in} , is created by a stable zener reference element using a compensated current source to supply it with constant excitation current. Similarly, the output of the power supply is: $E_{out} = E_{in} R_f / R_{in}$.

The output can be changed by varying either R_f or R_{in} . Varying R_{in} would then cause a variation in the current I_1 supplied by E_{in} . A change in I_1 causes a change in E_{in} because the stability of a zener diode is dependent upon specific constant operating conditions. Because varying R_f has no effect on I_1 , it is the preferred method for varying output voltage.

Most supplies can vary the feedback resistor, R_f , from a remote source either by providing a pair of terminals in series with R_f or by replacing it entirely. Both methods permit control of the output voltage from some point far removed from the regulator location. This is referred to as remote programming. Since I_1 is a constant, the power-supply user can easily program the output voltage linearly by varying the feedback (or programming) resistor. As would be expected, a supply should only be programmed within its rated limits of operation.

Operating Parameters

Let us examine the important power-supply operating parameters, relate them to circuit performance, and investigate their limitations.

Load Regulation. Load regulation is defined as the amount the output voltage will vary for a specified change in load (output) current. It can be seen from Fig. 2B that load current is supplied by the pass transistor to the load. Because a transistor is a current-amplifying device, the current required at the base of the pass transistor is only a small fraction of the load current. The change in the error amplifier input current (I_2) required to supply this base current is extremely small and normally less than a microampere. This change in input current causes a change in the error voltage (ϵ) which is the main factor affecting load regulation. For the circuit shown: $\Delta E_{out} = \Delta \epsilon (1 + R_f / R_{in})$.

Load regulation depends upon two components, then; one a constant and the other a proportion of output voltage. The constant component is more important when a supply is operated at or near zero since, under these conditions, R_f / R_{in} would be essentially zero. When the power-supply operating point is such that R_f / R_{in} is much greater than unity, the variable component of regulation predominates. Because power-supply output requirements do vary, the user must recognize the need for specifying load regulation in two quantities. The series-regulated power supply will typically have a variable regulation band of from 0.01% to 0.1% of output voltage and a fixed component of from 1 to 5 mV for load current changes of from no load to full rated load. Values above and below this band normally are considered poor and good regulation, respectively.

Line Regulation. This parameter defines how much the output voltage will vary for a specified change in a.c. input voltage. This change causes a number of variations within the supply, e.g., "B+" for the pass transistor changes, the error-amplifier bias supply voltage changes, and the reference zener diode (E_{in}) current source changes.

Because the pass transistor is within feedback loop, a change in its "B+" potential will not cause an appreciable change in E_{out} . Referring to Fig. 2B, the minimum capacitor-filter voltage must be equal to or greater than the maximum output voltage plus the pass transistor saturation voltage plus any internal voltage drops around the power loop, plus the peak ripple voltage across the capacitor-filter. Any capacitor-filter voltage less than the sum of these voltages will cause the pass transistor to become saturated, resulting in loss of control of the output and

causing the excessive ripple of the capacitor-filter output to appear across the output terminals.

At the high end, the a.c. input is limited by the amount of power the pass transistor can dissipate. For a given load current, the power in the pass section will be a maximum when the difference between the capacitor-filter voltage and the output voltage is a maximum since this difference appears directly across the pass transistor. When developing the power rating for a unit, the power-supply manufacturer starts by selecting a reasonable a.c. line variation (usually 105-132 V r.m.s.), and then designs a transformer to deliver maximum output voltage at full load with low line input. Power dissipation capability required with maximum input line voltage and minimum d.c. output voltage determines package size because the power circuitry required for dissipating the excess power contributes largely to physical size. Its direct contribution to over-all gain and regulation is relatively small.

In addition to voltage variations, the a.c. input can also cause frequency variations. Normally a power supply is designed to operate over a wide input frequency range. The lower limit will be determined by either excessive transformer heating or increased ripple across the capacitor filter. The lower limit can usually be extended by reducing the maximum load current requirement. The upper limit is determined by a reduction of input voltage due to transformer leakage inductance or by increased output noise. Series-regulated power supplies are, in most cases, operable from 45 to 440 Hz. The effect of frequency variations on regulation is usually negligible.

Ripple and Noise. Fig. 3A illustrates a typical ripple and noise pattern at the output of a series-regulated power supply. Three distinct signal sources are detectable: (1) random noise generated by the reference zener and error amplifier as characterized by the thickness of the line; (2) ripple attributed to the line frequency, which has its origins in the reference zener bias circuit and pickup in the circuit wiring; and (3) low duty cycle spikes synchronized to the line frequency, which are generated by the input rectifiers and transmitted to the output. These spikes are normally reduced by using r.f. attenuation techniques.

To properly describe this over-all a.c. component at the d.c. output requires an r.m.s. as well as a peak-to-peak limit.

Temperature Coefficient (TC). The amount the output voltage of the supply changes in proportion to the ambient temperature (with all other operating conditions remaining constant) is expressed as the TC. The TC is mainly dependent upon the closed-loop parameters of the supply. Changes within the amplifier after the first stage caused by temperature variations can normally be neglected (assuming that the magnitude of these changes is within the dynamic range of the amplifier) since the effect reflected back to the input would be attenuated by the gain of the subsequent stages. Acceptable TC's are normally less than $0.05\%/^{\circ}\text{C} + 1 \text{ mV}/^{\circ}\text{C}$.

Because load and line changes cause dissipation within the supply, internal ambient temperatures will vary independent of external ambient changes. Such variation could be from 10°C to 40°C at different locations within the package, depending on component layout and thermal properties. The effect would be the same as changing the external ambient temperature. This effect is not specified on a manufacturer's power-supply data sheet because its calculation depends on the user's techniques for ventilating and/or cooling, together with the magnitude of the user's line and load changes. However, it should be taken into account by system designers who use power supplies in large quantities in restrictive environments.

Recovery Time (Transient Response). A power supply will usually be required to operate into a varying load,

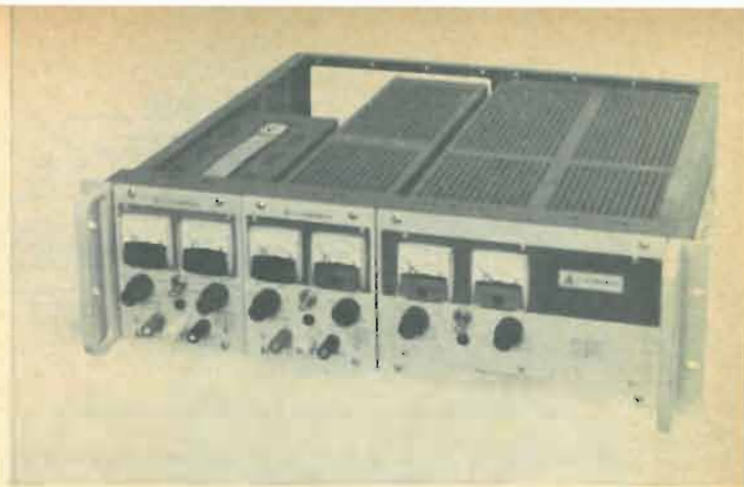

Three laboratory power supplies mounted in rack adapter.

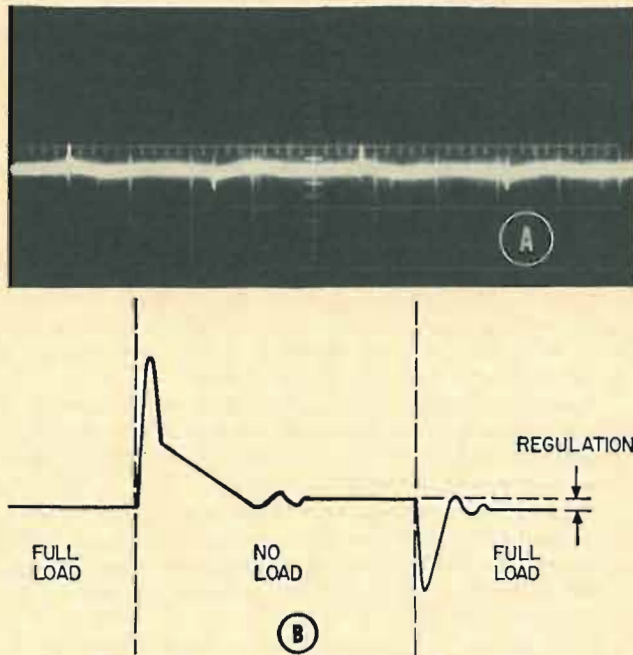

Fig. 3. (A) Waveform showing typical ripple and noise. (B) Transient response of series-regulated power supply.

with extremely fast variations in relation to the response time capabilities of the power supply circuitry. Hence, power supply output terminals are shunted by a capacitor, which supplies reserve energy when operating into rapidly varying (transient) loads. Fig. 3B illustrates the transient response time of a series-regulated power supply. Changing from a full-load to a no-load condition results in an output voltage spike caused by the inherent inductance of the internal and external circuitry. Simultaneously, the power supply still supplies load current to the output capacitor until the amplifier regains control. This causes the output capacitor to be charged to a voltage higher than the desired output voltage. The power supply's internal circuits will then bleed off this excessive charge until the output voltage reaches the selected level. Going from no-load to full-load first causes the load current to be drawn from the output capacitor since the amplifier cannot respond immediately to the changed power requirement. When the amplifier again regains control, the capacitor is recharged and the desired output voltage is restored.

It is apparent that the nature of the load can have a significant effect on the transient response characteristic. A highly capacitive load will cause small peak excursions but relatively long settling times, while a highly inductive load will have just the opposite effect on these characteristics. Transient response is normally specified as the time required to return and stay within specified voltage limits surrounding the regulation band. For instance, a typical

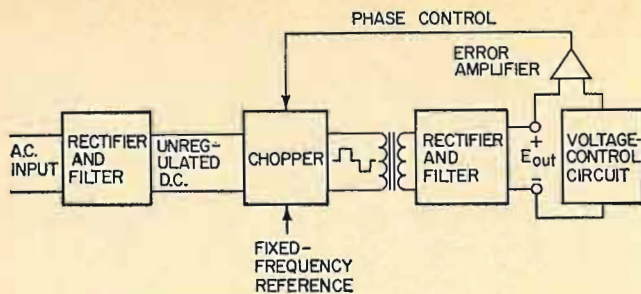

Fig. 4. Efficient phase-modulated switching power supply.

specification would be 100 μ s to be within 100 mV of the regulation band. This specification refers to a resistive-type load, where error sensing is done at the power-supply output terminals.

Stability. Assuming that a power supply is operating from a constant input line and into a constant load while installed in any environment with fixed ambient temperature, small deviations, or drift, of its output voltage can be observed. This drift is referred to as the stability characteristics of the power supply. Even when operating under constant conditions, the power supply creates ambient differentials within isolated portions of its circuitry. Thermal currents thus created cause variation in temperature-sensitive components and mechanical stresses in critical potentiometers resulting in output variations. Easily available components used in today's circuitry will yield an output voltage stability of 0.1% or better for 8 hours after an initial warm-up period.

The power supply is a complex instrument, capable of many performance options and features. Consequently, a suggested model should be analyzed for intended application to insure the most economical and efficient handling of the customer's requirements. A convenient way of specifying performance is to select a regulation band which encompasses all the static operating conditions. This involves specifying upper and lower limits for each of the operating conditions.

There are many other specifications applicable to power-supply use: environmental specs describing vibration, shock, temperature cycling, and humidity limits, as well as specs for radio-frequency interference generation.

Whenever a standard model cannot meet a user's needs, a specification can be generated by the user, tabulating performance goals and physical requirements. This normally requires liaison with a power-supply manufacturer's applications engineer who will insure reasonable specifications and a clear understanding of the problems involved in creating a modified or custom power supply.

Other Types of Regulators

The series-regulated power supply is the most widely used type. Its major attributes are versatility and excellent performance; however, its greatest drawback is its low efficiency. When the input and/or output vary widely, the efficiency can be as low as 25% and not much better than 50%. For example, a 5-volt power supply with a $\pm 5\%$ output variation and a line voltage specification of 105 to 132 V r.m.s. will have a typical worst-case efficiency of 25% caused by the combination of high line input, low-voltage output with full-load operation. The efficiency can approach 50% for units with higher voltage ratings but will not rise much higher. The internal power dissipation can become excessive in uses requiring large amounts of power in a single system.

A partial solution to the problem is to utilize a method of power control employing switching techniques. This method, in turn, causes deterioration in such performance characteristics as response time, ripple, and noise, in addition to causing increased RFI. Recognizing these deficien-

cies, a user can obtain operating efficiencies exceeding 70%. In such circuits, a different and more efficient power control mechanism is substituted for the series regulating pass transistors.

One such technique is the use of line-voltage phase modulation with SCR's as discussed elsewhere in this Special Section. Another widely used high-efficiency system for power conversion is illustrated in Fig. 4. In this method, the a.c. input signal is first converted to unregulated d.c., then a chopping or switching circuit, controlled by a feedback loop, is used to produce a fixed-frequency output. The power is controlled by varying the duty cycle of this fixed-frequency output. A regulated d.c. output is obtained by rectifying and filtering this phase-controlled signal. The chopping frequency is normally many times higher than the input line frequency. This factor allows the use of a smaller isolation transformer which, in turn, makes possible the attainment of high voltages while using low-voltage control devices because the maximum output voltage then becomes a function of the transformer. Either SCR's or transistors can be used in the chopper section. SCR's handle large quantities of power but are limited to an operating frequency of about 10 kHz. Transistors are limited in power-handling capabilities but operate at faster chopping rates. This provides better response characteristics than SCR systems.

Making the Choice

When selecting a power supply, the user should evaluate three main factors:

Electrical Specifications. Consider the entire band of regulation desired instead of one or two attractive published specifications. For instance, a line or load specification of 0.005% is inconsistent with a temperature coefficient of 0.05%/°C. A power supply should be capable of operating with substantial input line variations. The load should be analyzed for severe demands such as those required by lamp filaments, motor windings, capacitor and pulsed loading. The performance of the power supply should then be evaluated accordingly. Special features and protective circuits for the load and for the supply should also be considered.

Mechanical Specifications. Intended usage should govern the physical appearance of the power supply. A laboratory supply should possess a full complement of meters and accessible controls whereas a system supply must be compact and adaptable to what may be a difficult mounting requirement. When necessary, system mounting can be provided together with accessible controls. The interior power-supply layout should allow convenient access for servicing or internal calibration and adjustment.

Thermal Environment. Power supplies, by the very nature of their use, generate heat. Control of temperature build-up can be accomplished either by convection or by forced-air cooling. Control becomes a critical factor when a power-supply rating is based upon the operating ambient temperature. When installed in large systems, the power supply presents a problem of great concern to designers. The units must be situated so that they do not heat up critical system components, yet they must still be capable of dissipating their generated heat into surrounding external ambient. For laboratory use, the power supply must possess no external heat sinks that can harm the user and cause damage to other equipment.

Before selecting a power supply, a careful check list should be made based on intended usage. Because a large capital expenditure can be involved in the supply and the circuitry dependent upon it, a selection must be carefully made based upon good judgment, intended use, and economics. Such an approach to selection is feasible only if all the characteristics associated with the product are understood and evaluated. ▲



The author is chairman of the Electronic Power Supply Committee of the National Electrical Manufacturers Association. A graduate of the Technical University of Warsaw, he worked several years in England before coming to the United States in 1951. He has worked in product engineering, application engineering, and has held management positions in marketing and manufacturing. He is a Senior Member of IEEE, a Registered Professional Engineer, and has a number of papers and articles to his credit.

How To Measure Power-Supply Performance

By B.C. BIEGA/Director of Engineering
Sola Electric Div., Sola Basic Industries

In order to compare specifications properly, measurements should be made according to certain standards. Here are the proper methods to use to avoid measurement errors.

A GLANCE at the ads in any magazine devoted to electronics and instrumentation technology will indicate the availability of many types of electronic power supplies. Their power outputs—ranging from milliwatts to kilowatts—are designed to provide fixed or variable voltage or current with almost any desired degree of precision and stability.

Growth of the power-supply industry, in a relatively short time, has been so rapid that it has been necessary to develop a whole new terminology to describe the performance characteristics of these power supplies. Further, as circuits and components have been improved, specifications for regulation, temperature coefficient, ripple, and drift have become tighter and tighter. But, for lack of common terminology and definitions, the user is often unable to make meaningful comparisons of the products of two different manufacturers.

Recognizing this problem, a number of major power-supply manufacturers are cooperating in the development of a Standard for Electronic Power Supplies through the Electronic Power Supply Committee of the National Electrical Manufacturers Association (NEMA). The Standard will include sections covering definitions, ratings, safety provisions, and measurement methods. This Standard is

expected to be completed late this year. Its adoption by all power-supply manufacturers will eliminate most of the existing confusion as to the exact meaning of the various specifications.

Avoiding Errors in Measurement

The tighter the power-supply specifications, the more difficult it is to make measurements verifying spec conformance. This is so because measurement errors can become greater than the change in output being measured.

For example, if a power supply is rated at 24 volts output with 0.01-percent load regulation, this means the terminal voltage varies no more than $(0.01/100) \times 24 = 0.0024 \text{ V} = 2.4 \text{ mV}$ for a no-load to full-load change. If rated output current is 5 A, the internal impedance is $(2.4 \times 10^{-3}) / 5 = 0.48 \text{ milliohm}$ or 0.00048 ohm. The measurement of load regulation is, in effect, the measurement of this internal impedance—not an easy matter. Note that 1 inch of #20 A.W.G. copper wire has a resistance of 0.84 milliohm at a temperature of 20°C. The contact resistance of an alligator clip may be much higher. Consequently, it is essential to eliminate any series voltage drops between the power-supply terminals and the point where the measurement is made, and to keep the current

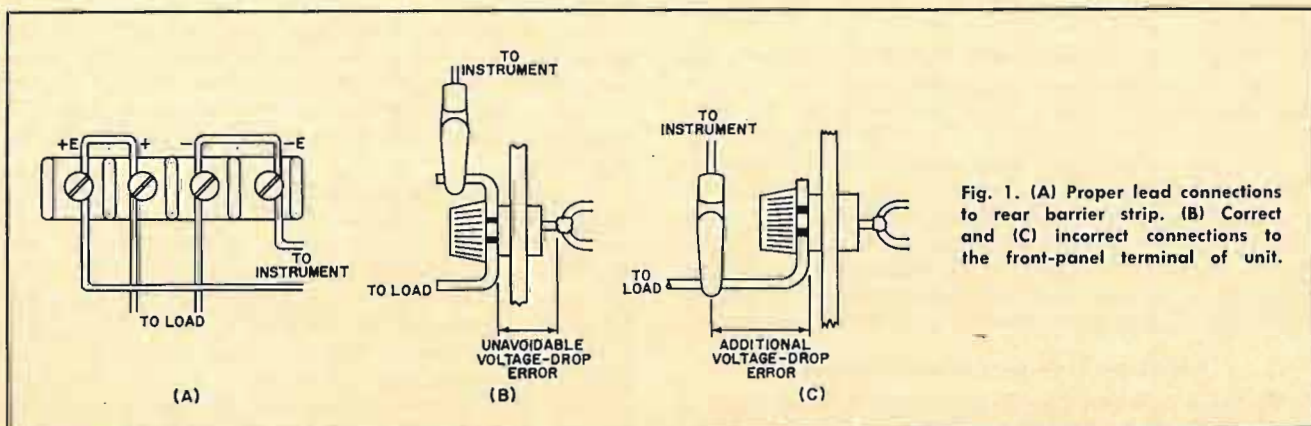

Fig. 1. (A) Proper lead connections to rear barrier strip. (B) Correct and (C) incorrect connections to the front-panel terminal of unit.

Minimum Equipment Needed

Oscilloscope	Minimum bandwidth, 100 kHz; Vertical sensitivity 1 mV/cm
V.T.V.M. Millivoltmeter Variable	With center zero
autotransformer	
A.C. voltmeter	
D.C. ammeter	
Power supply	With voltage output of same magnitude as one being tested

Preferred Equipment

Oscilloscope	Minimum bandwidth 20 MHz; Vertical sensitivity 100 μ V/cm; Differential input
Digital voltmeter or differential voltmeter	

Table 1. Equipment needed to make power-supply measurements.

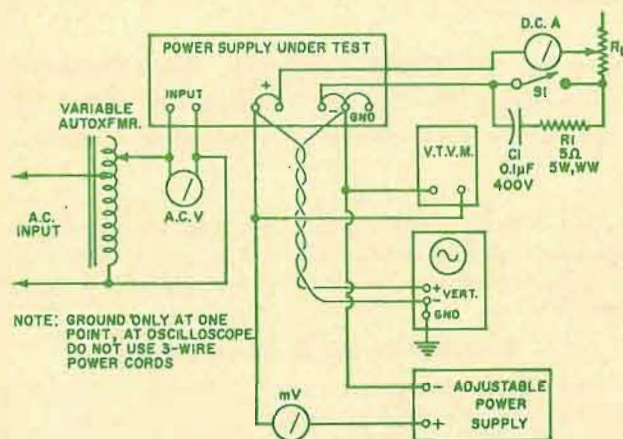

Fig. 2. Setup for measuring constant-voltage power supply.

flowing in the measuring circuit leads as low as possible.

Most precision power supplies have a rear panel containing two pairs of terminals; one for output or load leads, the other for remote error-sensing leads. Connect leads as shown in Fig. 1A to obtain the most accurate results.

In power supplies with only one pair of front-panel output terminals, connect the measurement leads as shown in Fig. 1B, rather than as in Fig. 1C. Even with the proper connection, an uncompensated source of error exists in the voltage drop on that part of the terminal post extending through the panel.

Separate pairs of measuring leads must be run from the same monitoring points to each instrument, avoiding mutual coupling effects. The pairs should be twisted to avoid pickup and, in some cases, shielded leads may be necessary.

Instrument resolution must be at least one order of magnitude better than the smallest quantity to be measured. For example, to measure down to 1 millivolt, the voltmeter must have a resolution of at least 100 microvolts.

Since the power supply being tested and the power supplies and amplifier in the measurement instruments all experience some drift or change during warm-up, it is essential that the equipment be energized, and the power supply connected to its load, for the specified warm-up time. If no specific warm-up time is indicated, allow a minimum of 30 minutes for the purpose.

Constant-Voltage Power Supplies

The most important measurements to be made are line and load regulation, PARD (Periodic and Random Devia-

tions) which includes both ripple and noise, and transient recovery time. Table 1 lists the minimum and preferred equipment needed.

Fig. 2 shows the test set-up using the "minimum" equipment. The variable autotransformer is used to vary the monitored input voltage to the power supply. Make sure the rating of the autotransformer is 20 percent higher than the total output rating of the power supply, since it must handle the power-supply losses in addition to the load.

Load resistor R_L must have a resistance and wattage rating capable of handling the maximum current at the maximum output voltage of the power supply. The v.t.v.m. is used to measure the power-supply output voltages while a d.c. ammeter is used to measure the output current. Switch S1 is used for measuring load regulation. C1 and R1 are connected across the contacts of S1 to minimize switching noise. A double-pole relay should be used for S1 since the second set of contacts can then be used for triggering the oscilloscope sweep.

The adjustable power supply is used to buck out the output voltage of the power supply being tested so that the zero-center millivoltmeter measures only the change in output voltage. The adjustable power supply must have an output at least as high as that of the unit being tested, but its power requirement is very small. Ripple content should be lower than that of the supply being tested.

If a high-quality 6-digit digital voltmeter or differential voltmeter is available, it can replace the v.t.v.m. and the bucking-supply/millivoltmeter combination.

Measurement Procedure: Energize the set-up at rated a.c. voltage. Adjust the power supply for maximum rated output voltage and adjust R_L to draw maximum rated current. If the power supply has an adjustable current limit, set it well above maximum current rating. If it has automatic constant-voltage/constant-current crossover, adjust R_L so that the current is at 90 percent of the crossover point. Check set-up for pickup and ground-loop effects by switching the power supply "off" and observing the scope first with its leads connected together and then to each of the output terminals of the supply. If any signal is observed on the scope, change lead routing and ground connections until the problem is corrected.

After the specified warm-up time, readjust R_L to obtain correct output current. Finally, adjust the bucking supply so that the millivoltmeter is nulled.

Line Regulation: Vary the input voltage over the specified range (usually 10 percent above and below normal) and record the millivoltmeter reading. This will provide ΔV , the absolute value of the line regulation, in millivolts.

$$\text{Percent regulation} = (\Delta V/1000E) \times 100$$

where E is the total output voltage, in volts.

For variable power supplies, repeat at various levels of output voltage. Also repeat with no load on the power supply.

Load Regulation: Switch the load "on" and "off" and record the change in output voltage, allowing time for re-establishment of equilibrium after each load change. Repeat for lowest and highest specified line-voltage settings. The calculations for percent regulation are the same as for line regulation.

Recovery Time: During the load-regulation measurement, an output voltage transient may be observed on the oscilloscope. Typically, it may appear as shown in Fig. 3A. If the dashed lines represent upper and lower limits of the specified transient recovery band, recovery time will be specified in the NEMA Standard as "time elapsed from the initial excursion of output voltage beyond the limit until it returns and stays within this band" Fig. 3B shows the case of an overshoot along with an undershoot. Unless otherwise specified by the manufacturer, the transient

recovery band is equal to the regulation band and is centered on the average of output levels before and after load change.

PARD (Ripple and Noise): The PARD of the power-supply output is a new and preferred method of specifying ripple and noise (periodic and random deviations) by indicating its maximum peak-to-peak value in millivolts. The value can be observed directly on an oscilloscope (Fig. 3C). The r.m.s. value of ripple, which is sometimes specified, may be two to four times lower in value, depending upon the waveform of the ripple component and the amount of noise present. The r.m.s. value may be measured by substituting a sensitive true r.m.s.-reading a.c. meter for the oscilloscope.

In order to detect high-frequency spikes on the output, a scope with at least a 20-MHz bandwidth is required. In fact, a differential oscilloscope with special coax cables and connectors must be used to accurately measure the amplitude of high-frequency spikes.

Note that a 60-Hz component in the ripple is usually indicative of undesirable stray pick-up. This should be eliminated to obtain a correct measurement of PARD.

Constant-Current Power Supplies

To measure constant-current power supplies, variations in output current (due to input line or load variations) are changed to variations in voltage drop across a series sensing resistor R_s . Then the procedures outlined for constant-voltage power supplies can be followed. The observed millivolt values are divided by the value of R_s to obtain milliampere current deviations.

However, difficulties in obtaining accurate results are even greater here than for constant-voltage supplies. For example, if the rated output of the power supply is 10 A and load regulation is stated as 0.01 percent, the specified current change is actually $10 \times 0.0001 = 1$ mA. If the sensing resistor R_s is 0.1 ohm, the voltage drop across it at rated current will be 1 V, while the change in voltage due to regulation will be 1 mV. This magnitude of change will also occur even in a precision resistor with a temperature coefficient of 20 ppm/°C if its temperature increases 50°C during this test.

Therefore, the sensing resistor must be selected with a power rating of at least 10 times (preferably more) the power dissipated in it at full rated current. Its resistance value should be chosen to provide an approximate 1-volt drop at rated current. A higher value would help in making measurements, but would reduce the available compliance voltage of the supply and tend to increase the circuit resistance when load resistor R_L is shorted out during the load regulation test.

A good quality ammeter shunt or a precision wirewound resistor should be used. To avoid sudden changes in its temperature, it should be shielded from drafts and preferably placed in an oil bath. The sensing leads must be connected between the resistor and its load terminals, as shown in Fig. 4. Keep all sensing leads as short as possible.

Load resistor R_L should be selected so that the supply's voltage output does not exceed its permissible compliance voltage rating. In the case of constant-voltage/constant-current supplies with automatic crossover, the supply's voltage output should not exceed 90 percent of its constant-voltage operating value. It is desirable to use a fixed resistor of ample power rating here. Small resistance changes at the brush contacts of a rheostat will show up as additional noise in making the PARD measurement. The power-supply voltage-limit control must be set at a level well above the maximum compliance voltage used in the tester.

Current flowing through the output voltmeter will show up as an additional load on the supply; therefore, a high-

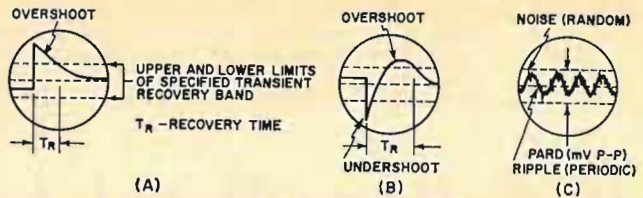

Fig. 3. (A), (B) Typical output voltage transients and recovery times. (C) PARD is specified in millivolts, peak-to-peak.

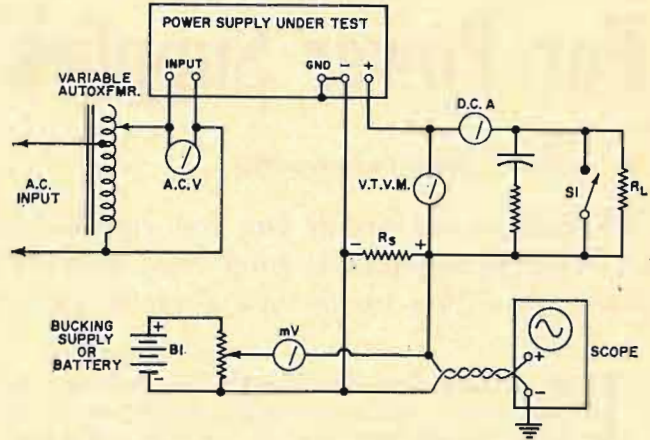

Fig. 4. Setup for measuring constant-current power supply.

impedance v.t.v.m. should be used, connected as shown.

Note that switch S1 shorts out the load resistor when closed. Therefore, the load regulation test is made by switching from rated load to short-circuit load.

Temperature Coefficient & Drift

Temperature coefficient tells us how the regulated output is varied as a result only of changes in ambient temperature, and is specified in absolute change ΔV or ΔI , or as a percentage change, per degree centigrade. This variation is not generally linear and should be specified as a maximum rate of change that occurs anywhere within the specified operating ambient temperature range of the supply. To measure this coefficient, an oven with precise temperature control is needed.

The power supply is placed in the oven and the temperature control is varied in 10°C steps over the entire specified range. After each temperature change, it is necessary to wait for the output to stabilize at its new level. This may take about 30 minutes for each step. It is important to maintain all other parameters (such as input line voltage and load resistance) constant. Stability of the measuring instrument is an important factor in making accurate measurements. It is also desirable to retrace all temperature points in the reverse direction to average out any errors that may occur.

Drift is the maximum change of output over a period of eight hours with all other parameters held constant. It is the most difficult characteristic to measure precisely, because unavoidable changes in the line voltage, load resistance, ambient temperature, and especially drift of the measuring instruments may have as great, or even greater effect on the measured supply output voltage or current than the inherent drift of the power supply itself. Tests should be conducted with both the power supply and all measuring equipment held in an ambient temperature which varies less than 1°C.

Measurement of drift should not begin until initial warm-up is completed. The output and all other parameters (such as ambient temperature and input voltage) must be checked every few minutes during the eight-hour period. Obviously, strip-chart recorders are ideal for this purpose. ▲

The author, Assoc. Professor of Electrical Engineering at Pratt Institute, received his B.E.E. Cum Laude from CCNY in 1951 and attended Columbia and Hofstra Universities (M.A. in Physics, 1958). His areas of interest are solid-state electronics and computer logic. He is the co-author of "Semiconductor Fundamentals: Devices and Circuits" and is currently at work on a new book, "Electronic Circuit Analysis" which will be published in the very near future.



IC Voltage Regulators For Power Supplies

By A.H. SEIDMAN/Contributing Editor

The integrated circuit has now invaded the power-supply industry. IC voltage regulators, some with current ratings of 2 amperes and load regulation up to 0.05 percent, offer new design opportunities.

THE integrated circuit, already well-established in digital-circuit applications and a growing factor in analog systems, has made its debut in power supplies. Typical of the industry, the five firms in Table 1 are marketing monolithic and hybrid IC voltage regulators in TO-5 and other small-size packages. Based on proven discrete designs, these units are capable of delivering up to 2 amperes at regulated voltages as high as 48 volts with 2 percent or better load regulation. Prices range from approximately \$6 to \$60 each in small quantities. With additional external components, the capabilities of some of these devices can be extended to current ratings as high as 25 amperes and voltage regulation on the order of 0.025 percent.

The advantages of integrated circuit regulators over conventional designs are numerous. These include small size, potentially greater reliability because of fewer connections, packaging flexibility in OEM designs, small inventories, and small design and lead times.

Two basic circuit configurations used for voltage regulators are the emitter-follower and series-regulator circuits of Figs. 1A and 1B, respectively. In both circuits a Darlington pair is used for the pass transistor where Q1 is a power device and Q2 a small-signal transistor. The small-signal transistor requires little base current thus permitting resistance R to be large. A large value of R simulates a constant-current source for the reference zener diode, thereby providing improved regulation.

The Darlington pair operates as an emitter-follower, reducing the output impedance of the unregulated source. Although it is simple and inexpensive, the voltage output of an emitter-follower regulator is limited to a value approximately equal to the zener diode voltage and load regulation is not much better than 2 percent.

In the series regulator, a portion of the output voltage that appears between the base of the control transistor (Q3) and common (pin 7) is compared with the zener reference voltage. The difference voltage is then amplified by the transistor. Assume, for example, the output voltage tends to increase because of a rising input voltage; the difference voltage increases and the collector current of Q3 rises. The collector-base voltage of Q2 increases and almost the entire change in voltage appears across Q1; the output therefore remains essentially constant. The series regulator is flexible and its regulation can be made to exceed 2 percent.

Integrated-circuit regulators share certain common features that must be considered by the applications engineer in his design. These features are:

1. The d.c. unregulated input voltage must be greater than the desired d.c. regulated voltage by approximately 2 to 15 volts, depending on the manufactured device used.
2. The operating temperature range is typically from -55°C to $+125^{\circ}\text{C}$.
3. Most units can be used with external discrete or IC components to extend their current range or improve regulation. These components, however, can take up more space than the IC regulator.
4. For some applications, an external heat sink may be required. Specific details can be obtained from the manufacturer's data sheet.

To illustrate the flexibility of IC voltage regulators, the Westinghouse WM 110 monolithic regulator of Fig. 1B will be used as an example. Selling for \$25 in small quantities, the circuit is housed in a low-profile TO-3 can and is rated at 0-2 amperes from 8 to 48 volts; load regulation at 1 ampere is 2 percent. Because the chip substrate and case are at ground potential, the device can be bolted di-

Table 1. A listing of some currently available IC voltage regulators and their important characteristics.

MANUFACTURER & NUMBER	TYPE	PACKAGE	MAX. AMPERES	REGULATED OUTPUT (V)	UNREGULATED INPUT (V)	PERCENT LOAD REGULATION	COST (\$) (small quan.)
Beckman 803.	Hybrid	Flat	0.5	21 to 32	27 to 38	0.05	30
Bendix BN-4100	Discrete	TO-3	1	5 to 25	9 to 40	2	6.60
Fairchild SH 3200	Hybrid	TO-5	50 mA*	8.5 to 30	10.5 to 35	0.05	50
National Semiconductor LM 100	Monolithic	Low-profile TO-5	20 mA*	2 to 30	8.5 to 40	0.5	60
Westinghouse WM 110	Monolithic	Low-profile TO-3	2*	8 to 48	10 to 51	2**	25

* Can be extended with external transistors, see text. ** Can be improved with external components, see text.

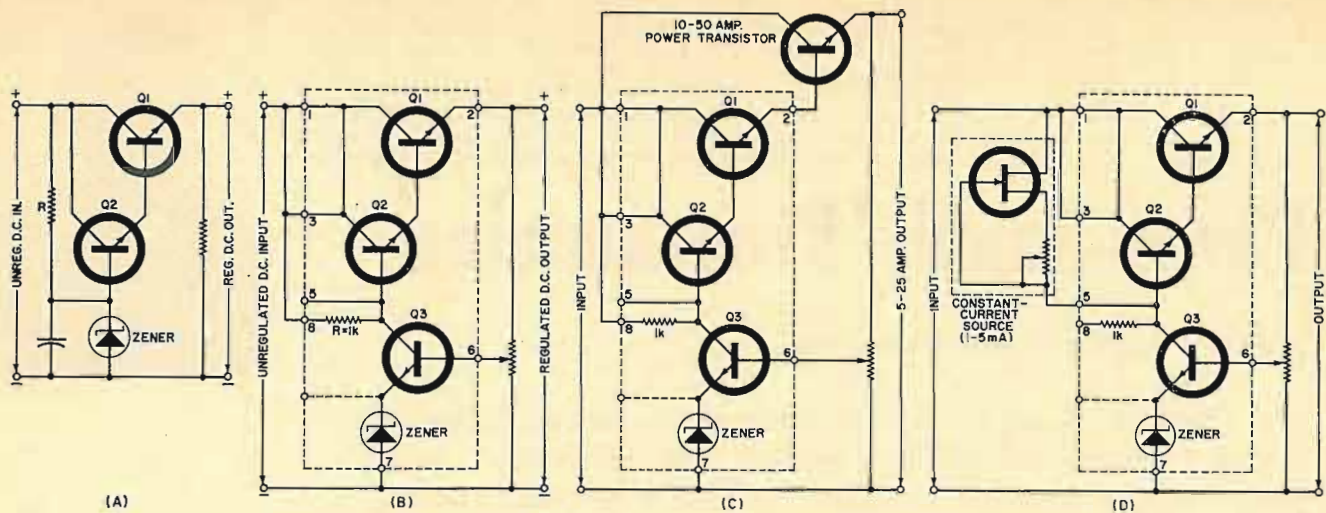

Fig. 1. (A) Emitter-follower as used in Bendix discrete regulator. (B) Series regulator used in Westinghouse monolithic unit. Methods of increasing the capabilities of an IC regulator. (C) Increasing current. (D) Improving regulation.

rectly to a chassis or to structure members for heat sinking.

For increased power handling, a discrete transistor may be added to form a triple Darlington, as shown in Fig. 1C. No additional biasing components are required and the 2-ampere output of Q_1 is sufficient to drive 10- to 50-ampere power transistors to provide outputs from 10 to 25 amperes. Regulation may be improved by the use of an FET as a constant-current source for the zener diode (Fig. 1D). Regulation obtained with this modification is on the order of 0.1 to 0.2 percent for input voltage variations of ± 20 percent and load variations of 1 ampere.

If precision voltage regulation is needed, the feedback signal to pin 6 may be boosted by another amplifier. With, for example, the *Westinghouse* WM 115 differential IC amplifier inserted into the circuit at pin 6, regulation will hold to 0.025 percent over a 2-ampere load range and a ± 20 percent input voltage variation. Short-circuit protection can be provided by placing a small series resistance at pin 2 and having the voltage drop across this trip a small transistor whenever over-current conditions exist.

Beckman is offering its Series 803 thick-film hybrid voltage regulator with voltage output between 21 and 32 volts. Selling for \$30 in small quantities and packaged in a small rectangular housing which is compatible with both flat-pack and dual in-line IC packages, the device handles a maximum of 0.5 ampere and provides 0.05 percent regulation for both line and load variations. Referring to Fig. 2, a triple Darlington is used to provide a gain greater than 10^6 . A constant-current source comprising zener diode D_1 and transistor Q_1 operates between the unregulated input voltage source and the common line to provide an initial regulated constant current which is essentially independent of input voltage variations. The remaining circuitry is fairly similar to that used in the *Westinghouse* and other regulators.

Bendix has a series of discrete-circuit regulators housed in the standard TO-3 package. In the least expensive BN-4100 series, which sells for \$6.60 in small quantities, an emitter-follower regulator (Fig. 1A) delivers 1 ampere. Output voltages of 5, 6, 12, 18, or 25 volts with load regulation in the range of 2 percent are available. Other units in the BN-4000 line provide 1 percent regulation and are higher in cost.

The monolithic (LM 100) voltage regulator made by *National Semiconductor* is packaged in a low-profile TO-5 can. Selling for \$60 in small quantities, the output voltage is adjustable from 2 to 30 volts; load regulation is 0.5 percent maximum. Rated for a load current of 20 mA, the range can be extended to currents greater than 5 amperes by using external transistors.

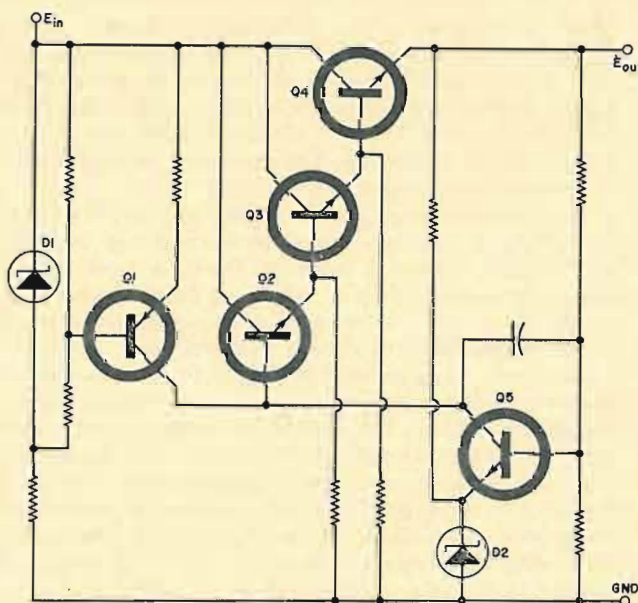

Fig. 2. Schematic of Beckman's hybrid voltage regulator.

Fairchild's SH 3200 adjustable hybrid voltage regulator is housed in a TO-5 can. A complementary version, the SH 3201, is also available for negative regulated voltages. Load regulation of 0.05 percent at 50 mA over an adjustable voltage range of 8.5 to 30 volts is obtained with the aid of the internal FET acting as a constant-current source for the zener diode. An external transistor extends the current range to 5 amperes. Cost of the SH 3000 is \$50 in small quantities.

Other manufacturers producing comparable IC voltage regulators include *Amelco Semiconductor*, *Bourns*, *Continental Devices*, *General Instrument*, and *Raytheon*.

Where space and reliability are of considerable importance, the IC voltage regulators are superior to those using separately packaged, discrete components. IC regulators are especially attractive in systems where it is desirable to have many local regulators for noise isolation rather than one central power supply. Also, because of their small size, the designer has greater flexibility in layout, permitting him to come up with an optimum package size.

If cost is the important factor, the IC regulator may not always be able to compete with discrete designs—at least for the present. There is little doubt, however, that with improved technology and increased production, these units will drop in cost and become competitive with discrete regulators of comparable operating characteristics. ▲

The author is engaged in the development and marketing of d.c. regulated power supplies. He is the author of the "Kepco Power Supply Handbook" and various magazine articles on regulated power supplies. Prior to his association with Kepco, he served with the Army Ordnance Corps, attached to the Army Rocket & Guided Missile Agency (ARGMA), Research Branch, at Redstone Arsenal, Alabama. Preceding this service, he did circuit design in d.c.-d.c. power supplies with Universal Transistor Products Corp. of Long Island. He holds a BSEE from the Polytechnic Institute of Brooklyn.



Power-Supply Programming

By PAUL S. BIRMAN / Applications Engineer, Kepco, Inc.

The feedback circuit of the regulator section is well suited for use in adjusting the supply's output. Such adjustment, called programming, may be done either locally or at a remote location.

REGULATED power supplies are often used in circuits and systems where the ability to control, vary, or modulate the output is required. A remarkable property of the regulator section of the modern power supply is that its feedback mechanism is just as well suited to the problem of control as it is to the maintenance of a constant output voltage or current. The process of varying a power supply's output is called *programming*.

The output of many power supplies may be programmed by varying a resistance—or a conductance—or by applying a signal voltage or current. These, in turn, may be shaped or controlled by a variety of function generators, motor-driven devices, or may be output-related to the power supply itself to close a feedback loop.

In general, programming is limited to those power supplies whose design does not depend on mechanical aids to dissipation limiting. For example, units employing variable autotransformers as part of their control will normally be incapable of electronic *remote* programming (except by the use of motor-driven or similar mechanisms). Similarly, some power supplies that employ range switching—where that switching involves transformer taps—will usually be limited to external control within the span of any one range.

Error sensing is also provided with most precision power supplies to allow the equipment to feed back its corrective signals over a wire path separate from that used to deliver current to a load. This allows a power supply to include the drops in its load wiring as part of its own internal resistance, joining, among other items, the transformer resistance and rectifier drops. The process of compensating for an unwanted drop in the load circuit may be considered a form of *restricted programming* in which the supply *programs itself* by the needed amount. Even power supplies using mechanical control and otherwise not considered programmable, will have a 0.5 to 1-volt programming range for the sensing circuit. Simpler power supplies lacking feedback control mechanisms will, of course, not have even the degree of programming needed for remote error sensing.

Analysis of a power supply in terms of its signal flow rather than its power flow may be aided by a symbolic diagram (Fig. 1A) which reduces the supply to three basic elements:

1. A raw d.c. source, the output of a transformer, rectifier, and filter.
2. A regulator element, typically a tube or transistor, in series with the raw d.c. (An equivalent analysis could also be drawn for a shunt regulator.)
3. A high-gain d.c. comparison amplifier connected to

drive the regulator in such a way as to maintain a null (zero volts) across its input terminals. (*If the amplifier has sufficiently high gain, its feedback voltage is practically the same as its output voltage so that its input voltage is vanishingly small, or essentially zero.—Editor*)

The amplifier input and the power supply's negative output form a feedback pair of terminals so that the output voltage will always be equal to the voltage across this pair (to maintain the input "null"). Several properties of the feedback pair are significant.

1. It passes negligible current into the amplifier and, therefore, possesses an apparent high impedance.

2. Any voltage achieved across the feedback pair will program the power supply's output one-for-one. Programming, then, becomes a matter of controlling the magnitude of the feedback-pair voltage.

Methods of Programming

The simplest method of programming involves placing a voltage source directly across the feedback terminals—perhaps a battery controlled by a potentiometer (Fig. 1B). Because of the high impedance, the potentiometer's wiper will not be loaded, yielding good linearity *vs* position. Programmed in this way, power supplies are sometimes used as impedance transformers. With "input" impedances in the megohm range and output impedances in the milliohm region, transformation ratios from 10^9 to 10^{12} ohms are common.

Becoming a bit more sophisticated, the feedback voltage might be controlled by placing a resistor across its terminals and contriving to pass a current through it. The IR product voltage will then program the output to an equal, but opposite, level. The current for the feedback resistance may be obtained from a separate source. If this current is constant, then the power supply's output voltage will simply be proportional to the resistance. For example, if the current is 1 milliamperes, the output will be 1 volt for every 1000 ohms of feedback resistance. This is often called the *programming ratio*; 1 milliamperes control current corresponds to 1000 ohms per volt, 2 milliamperes will give 500 ohms per volt, etc.

Output may also be controlled by varying the current; or the current and resistance may be varied simultaneously with the power supply's feedback circuit by simply multiplying the two, with the product being the power supply's output.

The current for the feedback circuit can be generated by connecting a current source *across* the feedback resistance (in which case the current generator must be capable of supporting the output voltage) or it may be con-

nected across the amplifier's null terminals. Since the null terminals support little voltage (because of the gain), this pair appears to have a very low, almost zero, input impedance, and so is easily driven by a current source. Since the current does not flow into the amplifier itself, the path takes it through the feedback resistor where its passage generates the IR drop needed to program the power-supply's output (Fig. 1C).

A current source in this position is readily simulated. Because the amplifier's input impedance is nearly zero, any voltage in series with a suitable resistance can be used to generate the needed current. (Since there is no voltage across the input terminals, the effective impedance across these terminals is close to zero. This nearly zero input impedance should not be confused with the very high "input" impedance of the feedback pair shown previously in Fig. 1B.—Editor.) The current will be the input voltage divided by its series resistor. This current, and thus the current through R_f , is subject to control by varying either the source, E_r (the reference) or its series resistor, R_r . Control will be directly proportional to E_r and inversely proportional to R_r . (It is directly proportional to the conductance $G_r = 1/R_r$.)

Writing the complete equation: $E_o = E_r = E_r (R_f/R_r)$.

The resistance ratio R_f/R_r is sometimes called the *operational gain*, or *closed-loop gain*. When either R_f or R_r is varied to control output, the operation can be considered equivalent to varying the *gain* of an amplifier with a fixed input (E_r). If the gain ratio is allowed to remain constant, output may be varied in the selected proportion by controlling E_r .

E_r may, of course, be any voltage level as long as it is used in series with the appropriate resistor to produce the control current. The current needed will be dependent on the value selected for R_r , with larger values requiring the least amount of current.

In most modern power supplies, a shunt-regulated zener source is commonly used to produce the stable reference (E_r). The current from it is determined by a precision series resistor (R_r) and is customarily between 1 mA (1000 ohms per volt) and 10 mA (100 ohms per volt). The feedback resistor (R_f) is made variable and is mounted on the front panel and labeled "voltage control". To qualify as a remotely programmable power supply, these elements are connected to the circuit *via* appropriate terminals and links, so arranged that users have access to any or all elements for the substitution of external components (Table 1).

Programming mechanisms might include a remote feedback resistor which is variable, stepped, sequenced, or driven by a motor; or it might include an external source of voltage substituted for the reference. This, too, may be variable, derived in whole or in part from a function generator, sweeper, or sensor output for process control.

Next, let us consider some of the important design parameters that are involved.

ELEMENT (control by)	OUTPUT	LIMITS	ADVANTAGES
E_r (feedback voltage)	Directly proportional, 1:1	Needs voltage equal to output	Impedance transformer
R_r (feedback resistor)	Proportional to control current	R_r must support voltage E_r	Direct linear program
R_r (reference resistor)	Inversely proportional	Current from reference varies	R_r need only support E_r
E_r (reference voltage)	Proportional to R_f/R_r	E_r must provide control current	Low-level programming

Table 1. Programming is done by varying one of these elements.

The ability of a power supply to make its output follow a program accurately, linearly, and with good resolution is largely a function of the comparison amplifier's gain. The higher this is the more nearly perfect is the comparison. The gain is usually reflected in the power supply's load regulation rating with 0.1% to 0.01% supplies requiring 80-100 dB of amplifier gain. Actually, the significant gain is the open-loop gain (A) less the closed-loop gain (R_f/R_r). The balance is called the "loop gain" or *feedback return ratio*.

Also involved in an analysis of accuracy or linearity are the amplifier's offsets (residual input voltages and currents) whose presence must be accounted for in determining the precise output.

With modern emphasis placed on varying output (rather than the traditional power-supply role of maintaining constant output), the question of a power supply's dynamics (behavior while varying) becomes significant. Typically, power supplies have used large capacitors across the output terminals. These capacitors are characterized by high energy storage, low a.c. impedance, and resistance to voltage change, making them ideally suited to the demands of the classical *constant-voltage* power supply. These same characteristics, however, make the traditional output capacitor unsuited to the demands of a variable (modulated) power supply. In particular, the capacitor affects the *programming speed*—or *slewing rate*, the rate of voltage change following a step command, say from a switched feedback resistor. (Slewing rate is measured as the chord from the origin to the first time-constant on the exponential response to a step command, as in Fig. 2.) The relationship $I = C dv/dt$, where dv/dt is the voltage rate-of-change, limits the slewing rate to the current divided by the capacitance. Typically, for most output filtered supplies, this will be just a few hundred volts per second.

Fast-Programming Supplies

Some manufacturers now offer high-speed, or fast-pro-

Fig. 1. (A) Simple series dissipative regulator type of power supply showing signal voltage relationships. E_o equals E_r . (B) Voltage repeater 1:1 programming produces impedance transformation from very high-Z input to very low-Z output. (C) A voltage E_r in series with R_r produces a current through R_f equal to E_r/R_r . This current times R_f produces program $E_o = E_r (R_f/R_r)$. Current arrows show direction of electron flow.

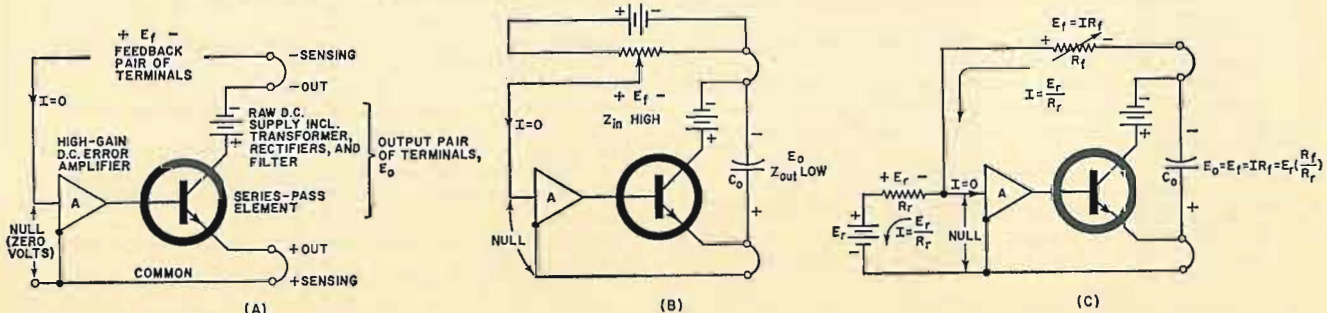

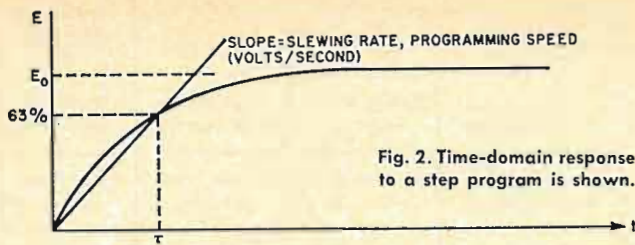

Fig. 2. Time-domain response to a step program is shown.

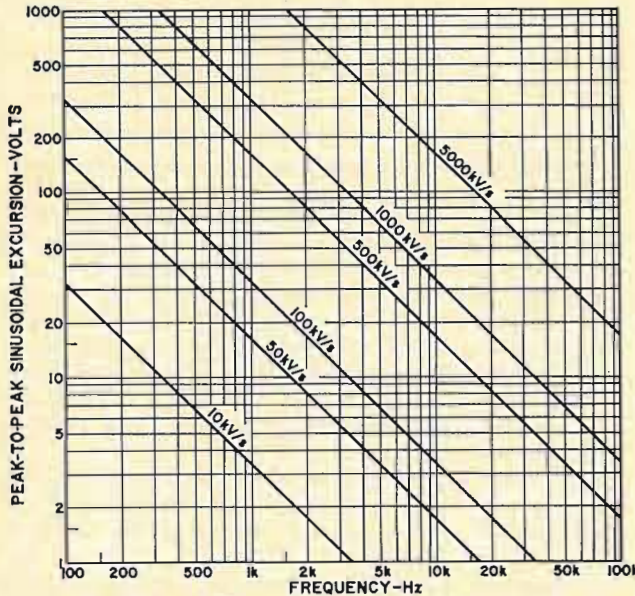
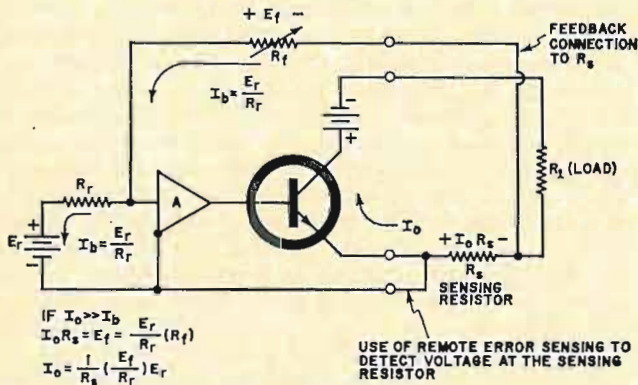

Fig. 3. Chart showing the maximum sinusoidal frequency vs the peak-to-peak voltage excursions for number of slewing rates.

Fig. 4. A sensing circuit for current regulation and control.



gramming power supplies. In these the output filter capacitance is reduced or completely eliminated. This yields relatively high slewing rates, on the order of $\frac{1}{2}$ to 2 volts per microsecond. Such power supplies are well suited to rapid programming of test circuits, or to digitally controlled step-value feedback-resistance programs. They may also be modulated with speech or other complex audio-frequency or sinusoidal waveforms, just as if the power supply were a wideband d.c. amplifier.

Sinusoidal bandwidth can be related to slewing rate by the chart in Fig. 3. This depicts the product $E_{p-p} \pi f = dv/dt$, which, for a given slew rate, dv/dt , and amplitude, E_{p-p} , plots the maximum sinusoidal frequency, f .

Power supplies used to regulate current are especially benefited by the capacitorless high-speed circuits. The transient response of a current regulator is a measure of its ability to restore the set current following a step load change. Since such a load resistance change calls for a corresponding change in the current regulator's output voltage, or compliance voltage, the speed of response is directly related to the voltage-rate-of-change, the programming speed. Essentially, the current regulator is a self-programmed power supply which automatically adjusts its output voltage to correspond to changes in load resistance, to maintain a constant voltage-resistance ratio.

Power supplies are made to control current, rather than voltage, simply by connecting their feedback resistor to a sensing resistor instead of the output load (Fig. 4). When this connection is made, the circuit regulates the voltage across the sensing resistor and makes it equal to the feedback voltage. Because the voltage across the sensing resistor is the product of output current and R_s , and since R_s is constant, then controlling the sensing voltage controls the output current.

The connection of the feedback resistor to either the load or sensing resistor—to the *point of regulation*—constitutes one of the power supply's *error-sensing* connections. The other is the connection between the reference voltage and the common terminal. By making these connections directly to the point of desired regulation, the voltage drops in the load-carrying wires are not included in the critical comparison of load voltage with feedback voltage, and the errors are compensated.

Modern regulators, subject to a variety of command controls, able to be modulated and capable of functioning as impedance transformers, summers, scalars, integrators, amplifiers, fulfill a growing role in the field of control engineering. By their ability to handle a small signal command, and respond to it with substantial power, such equipment can often simplify systems design, and reduce the burden on other equipment. ▲

OFTEN-USED POWER-SUPPLY TERMS

Ambient Operating Temperature: The range of environmental temperatures in which the supply is operated.
Bipolar: A system with two poles, polarities, or directions.
Compliance Voltage: Output voltage of a d.c. power supply in a constant-current mode.
Constant-Current Power Supply: A supply capable of maintaining a preset current through a variable load.
Constant-Voltage Power Supply: A supply capable of maintaining a preset voltage through a variable load.
Current Cut-off: An overload protective device designed to reduce load current as the load is reduced.
Current-Sensing Resistor: A resistor in series with the load that develops a voltage proportional to current.
Error Signal: The difference between the output voltage and a fixed reference voltage.
Filters: LC or RC devices arranged as low-pass devices. They determine output ripple value.
Frequency Response: A measure of a power supply's ability to respond to a sinusoidal program.
Isolation Voltage: The external voltage between the power-supply output and ground.

Lead, Lag Networks: Resistive-reactive components that control phase-gain roll-off versus frequency.
Load Regulation: The maximum change in output current or voltage with corresponding changes in load.
Overshoot: A transient rise beyond regulated output limits.
Programming: The control of a power-supply function by means of an external variable control.
Regulation: Maximum change in output caused by line voltage, load, temperature, or time changes.
Response Time: Time required for voltage or current reduction to 37% of its peak value after a step load or line change.
Ripple: The a.c. component in a d.c. output.
Series Regulator: A device in series with a power source that controls voltage or current output.
Short-Circuit Protection (Automatic): A current-limiting system that enables a power supply to operate into a short without damage.
Shunt Regulator: A device placed across the output which enables a supply to maintain constant output.
Stability (Long Term): Output voltage or current changes as a function of time.
Voltage Reference: A separate voltage source used as a standard.



The author jointly holds two patents in power-supply circuitry, one of which involves protection features in a voltage-extending circuit known as the "piggy-back" design. He holds BSEE and MSEE degrees from Newark College of Engineering. He is active in power-supply applications engineering and in contributing to the current NEMA meetings on standards in power supply specifications and definitions. He has been associated with the company (then known as Harrison Laboratories) since 1955; previously he was with the Television Research Dept. of Bell Labs.

Protection Circuits For Solid-State Power Supplies

By ARTHUR M. DARBIE/Marketing Manager
Harrison Div., Hewlett-Packard

Fuses and circuit breakers are much too slow for adequate protection. Hence, electronic circuits must be used to safeguard the supply and its load.

SOLID-STATE devices can break down in microseconds as a result of over-voltage or over-current. The traditional fuse and circuit breaker take much longer to respond to current and voltage excesses. Hence, protection circuits must be incorporated into modern regulated power supplies which use all-semiconductor circuitry.

It has always been necessary to protect the power supply when voltage or current gets out of hand; but more important, a power supply must have circuits (or devices) that protect *against ruining the load as well*. (One recent example: a \$300 power supply failed and ruined several thousand dollars' worth of IC's then under test.)

Current Limiting—The Basic Protection

Fig. 1 shows constant-voltage/constant-current (CV/CC) design, which contains all the basic elements for providing current-limit protection. The a.c. input passes through a power transformer and rectifier; filtered d.c. appears across filter capacitor C_1 . A series regulator, consisting of one or more power transistors, controls the flow of current through the output terminals and maintains a constant output voltage.

The series regulator is controlled by one of two comparison amplifiers; one for constant-voltage control, the other for current control. The voltage-comparison circuit compares a fraction of the output voltage with the reference voltage, and changes the conduction of the series regulator to hold the output to the desired value. The feedback loop works to maintain a zero difference between the two comparison amplifier inputs. The reference voltage is usually developed across a temperature-compensated zener diode which is powered independently, as shown. The current amplifier action is similar to that of the voltage amplifier. With the voltage across R_M held constant by feedback action, the current through R_M (which is the output current) must be constant.

The two comparison amplifiers cannot operate simultaneously. For any given value of load resistance, the power supply acts either as a constant-voltage source or as a constant-current source. Transfer between these two modes is accomplished automatically at a value of load resistance equal to the ratio of the output voltage control setting to the output current control setting.

Fig. 2 shows the ideal CV/CC curve; here the comparison amplifiers in both circuits have been designed for tightly regulated performance. Moreover, the controls in each are variable, and a precise protection limit exists for any load against *both* voltage and current runaway—and in a matter of microseconds.

By relaxing the design requirements in the current-comparison loop, the designer can reduce costs of manufacture and still obtain almost identical protection by variable current limiting (CV/CL). The slope of the limit characteristic is fairly steep, but not exactly vertical as in constant-current operation. In still less expensive supplies, the current-limiting function is less precise, and is not adjustable.

Fig. 1. Constant-voltage d.c. power supply showing additional circuit elements required for constant-current (CV/CC) operation. Circuit is essentially self-limiting and self-protecting. Variable controls are for setting output voltage and current.

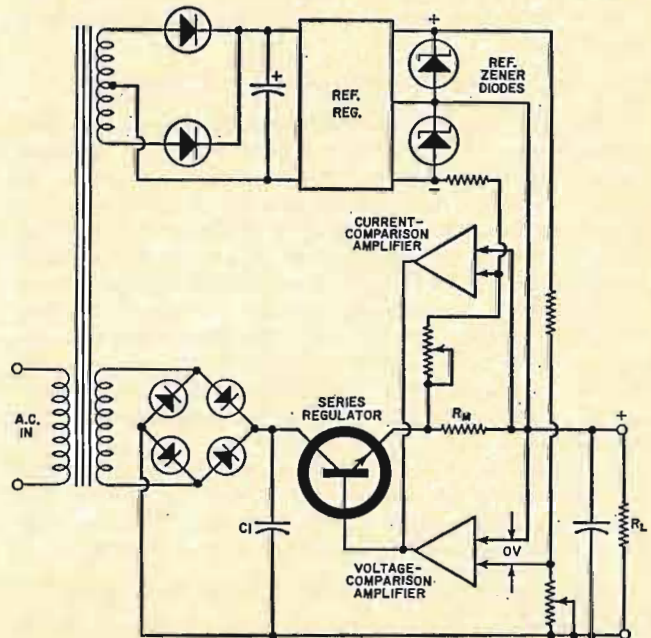

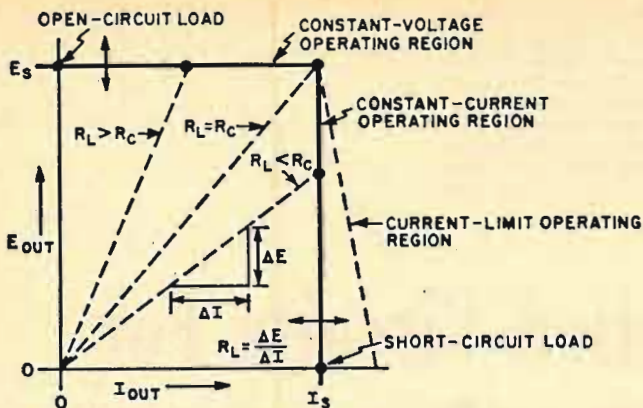

E_s = FRONT-PANEL VOLTAGE-CONTROL SETTING
 I_s = " " CURRENT " "
 $R_c = \frac{E_s}{I_s}$ = "CRITICAL" OR "CROSSOVER" VALUE OF LOAD RESISTANCE

Fig. 2. Operation of CV/CC and CV/CL power supply is shown.

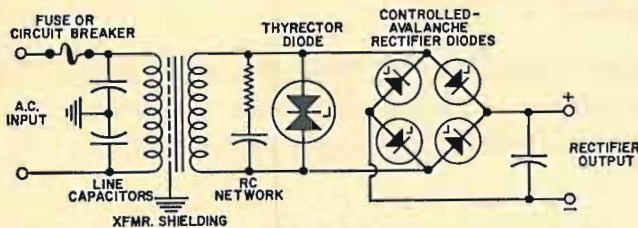

Fig. 3. Devices for guarding against line-voltage transients.

Another form of current limiting produces current cut-back when maximum voltage and current threaten the series regulators. Here, when the entire output voltage falls across the series regulator, output current as well as output voltage drop to some fraction of their former limiting values.

Note that in variable current-limiting models, one can obtain *constant-current* operation by restrapping rear terminals to reconnect the high-performance constant-voltage amplifier into a constant-current configuration. However, this mode does not offer the variable voltage ceiling useful for constant-current loads as would be the case with CV/CC supplies.

Other current-limiting techniques are used. One incorporates a "back-up" current-limiting circuit. This usually has a fixed limit value and acts only in the event that the first current-limiting circuit fails. Another current-limiting technique is to employ current-limiting saturable or adjustable transformers.

Safeguards Not Inherent in CL Designs

There are external conditions (such as sudden load, line, or controlling changes) which are not inherently protected against in CV/CL power-supply circuitry. Further, internal conditions to watch for are failure of power transistors in the series regulators, or malfunctions in either the current or voltage-feedback loops. A failed series regulator usually shorts and causes full voltage and current at the output. A malfunction in the voltage-control loop can cause voltage to run away (without exceeding the current limit), possibly destroying the output capacitor or load, and beginning a sequence of further failures within the supply. Current controls that open remove the current limit.

The ultimate step—for foolproof protection of the load and supply—is an independent circuit to provide fast clamp-down action at the output terminals. This is commonly called a "crowbar" circuit and is discussed later.

Additional Techniques for Protecting Supply

Programming surges can occur when the system status

suddenly changes and causes voltages to exceed the low input levels of the supply's feedback amplifier. A pair of clamping diodes can be inserted at the amplifier input to limit voltage surges of either polarity to less than about 1 volt.

Reverse polarity can occur when the supply is hooked up either to a highly charged load or to other power supplies in series, with the power supply turned off. A diode across the output may then be used to offer a low-impedance path to such reverse voltage and prevent any harmful effects in the power supply.

Similarly, when another supply is connected in parallel with the first (for greater output current), there may be a voltage reversal across the series regulator. Here again, a diode across the series regulator limits the reverse voltage and minimizes damage.

Heat-sinking, of course, is a standard technique for getting rid of what might be excessive or damaging heat. An additional refinement is to employ a *heat-sink thermostat* which opens the circuit at the series regulator upon reaching critical temperature. This is a good safeguard against high ambient temperatures which could cause internal damage to the power supply.

A power supply should also be designed to fend off *unwanted line-voltage transients*. A number of devices and techniques for this purpose are shown in Fig. 3. (This is a composite illustration only; no one design would use all the devices shown.)

If the fuse or circuit breaker is designed to open the circuit under conditions of 50% over-current, and if the components on the secondary of the power transformer are rated to withstand a 50% overload condition for periods equal to the time required for the fuse or circuit breaker to react, then a measure of protection against "chain-reaction" failure from line transients is provided.

However, short-term voltage transients can still couple through and cause damage to semiconductor components and false firing of SCR's in the rectifier circuit unless additional protection circuits are provided. In some cases, an RC network is strung across the power-transformer secondary to suppress the high-frequency component of voltage transients coming from the line or coming from the SCR turn-on action.

A thyrector diode can also be strung across the transformer secondary as protection against high-voltage transients. Normally the thyrector acts as an open circuit, but when a sufficiently high voltage is impressed across its terminals, it conducts heavily (much like a high-voltage zener diode), thus diminishing the magnitude of the voltage surge in the particular power-supply circuit to which it is connected.

Another voltage transient suppression technique involves controlled avalanche rectifier diodes. In the forward direction these behave like normal silicon rectifier diodes—in the back direction they act like high-voltage zener diodes which break down at a predicted voltage value. Long-duration surges can destroy controlled avalanche diodes (which usually fail by shorting), but in some cases, the circuit is designed so that this will happen in order to protect more costly components. (*Editor's Note: In addition to the items mentioned above, line bypass capacitors, chokes, ferrite beads, and power-transformer shielding may be used to reduce the effect of line-voltage transients.*)

Techniques for Protecting the Load

Many of the previous circuit techniques will protect a load merely by protecting the power supply, but they do not guarantee consistent protection. Excessive currents and voltages do occur (and harm the load) when limiting controls are disabled or accidentally misadjusted in the power supply *without* harming the power supply. The fol-

lowing techniques are intended specifically for load protection.

Of particular concern are the *over-voltage transients* that occur at turn-on and turn-off of the supply. A control technique is to establish circuit bias before turn-on of the main power circuit, and keep it on after turn-off. There are many ways to do this, such as with temperature-dependent switches, time-delay switches, or designing diode-controlled time delays into the circuit.

With remote sensing it is possible to connect the feedback amplifier directly to the load terminals so that the series regulator delivers the desired constant voltage (without degrading line and load regulation) at the load terminal. This compensates for the IR drop in the leads between output and load terminals. However, it is possible for sensing leads to disconnect from the load leads. This could lead to runaway voltages (reaching the limits of the rectifier output) unless a small resistance is permanently placed across each sensing leg. This resistance does not normally affect remote sensing action, but will act as a link to keep the feedback amplifier operative and avoid damage to the load. Some designers use a diode here across which a small voltage drop occurs if the sensing leads open.

Remote programming permits control of the power-supply output by means of a remotely varied resistance or voltage. This then takes the place of the front-panel controls. In some applications, particularly where the programming is done by a switch, these programming circuits can open momentarily or accidentally. Since the programming control takes the place of the voltage control in the normal circuit arrangement, an open circuit in the programming path means that the feedback circuits will try to drive the series regulator to an "infinite" voltage (practically speaking, reaching the limits of the rectifier). To protect loads from such accidental voltages, a zener diode can be placed across the power-supply programming terminals.

This zener diode is selected to have a breakdown voltage equal to the maximum power-supply voltage which can be tolerated by the load. If the programming terminals open, the programming current will break down the zener diode and limit output voltage to the zener diode voltage. (*Caution:* The zener diode should be rated to dissipate the power generated—the product of the breakdown voltage and the programming current.)

To provide medium- and high-power outputs in a power supply, silicon controlled rectifier preregulators are commonly employed (Fig. 4). Such a circuit can be added to the CV/CL or CV/CC circuits already discussed. Briefly, by controlling the firing time of the SCR's during each half cycle of input line frequency, the conduction of the bridge rectifier in the main power supply circuit is variably controlled. Output is then controlled in accordance with the load demands on the power supply. The chief reason for SCR control is to keep power dissipation through the series regulator to an efficient minimum by passing just the current needed to meet load demands.

Protection in SCR preregulated designs is needed for two important reasons: (1) output power is generally high (100 watts or more) and, if uncontrolled, could cause proportionately greater damage; (2) the transformer-rectifier designs using SCR's can in some cases produce output voltages 50% greater than the maximum rating of the power supply. Hence, such failures as series transistor short, open voltage controls, or open programming lead controls could cause serious damage to the load. Therefore, SCR preregulator supplies should include a separate preregulator overvoltage limit. Thus, any failure in the main regulator loop brings the preregulator limit into play—and restricts the maximum output of the power supply to this limit. Normally, such devices are an integral part of the

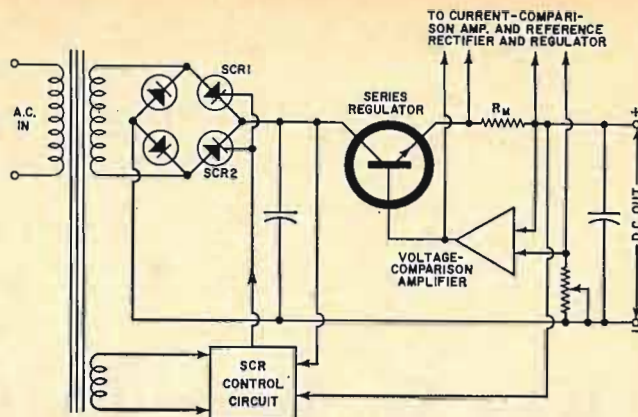

Fig. 4. Use of SCR preregulator with a CV/CC power supply.

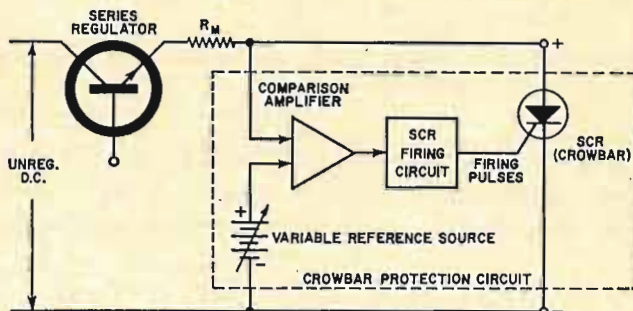

Fig. 5. Typical crowbar overvoltage protection circuit.

SCR control and are preset to about 10% above the nominal output voltage rating.

Crowbar—An Independent Circuit

To be doubly certain of avoiding damage to expensive, power-sensitive loads, a final protective device may be used which operates independently of the power supply and shuts down the output in microseconds. Such a device is the crowbar protection circuit. The most common protection is against output overvoltage.

(Note: The term "crowbar" stems from the use of an actual crowbar dropped across large capacitor banks to short and discharge dangerous voltages in transmitter power supplies.)

A crowbar circuit usually uses an SCR connected across the output of the power supply. When the output voltage exceeds a preset limit, the crowbar SCR is triggered into conduction (typically within 10 microseconds), effectively shorting the output of the power supply and removing the voltage from the load (Fig. 5). The SCR remains in the conducting state until the output of the power supply is removed.

The crowbar circuit can be set to have limits of over- and under-voltage; or to have voltage sensing and current sensing. It is completely independent of the main power supply. An additional safety device included as part of some crowbars is a fail-safe check which the operator can use to see if the crowbar is armed, without disabling the power output.

Caution: Crowbars are generally available from most manufacturers as options. However, the buyer should not use a crowbar made by one manufacturer with a power supply made by another firm. Although the crowbar would probably perform its function, the power supply may not be protected.

Most of the techniques described are circuit designs which come as an integral part of the power-supply package. Certain modifications can be made at the bench to achieve protection, but for critical applications and regular use, the power-supply buyer would do well to specify the protection he desires when he places his order. ▲

After 18 years in battery research and development, the author is considered one of the country's leading authorities on chemical power sources. A graduate of the College of the City of New York, he received his doctorate from Columbia University in 1949. Prior to assuming the position of Director of R & D at Burgess, he was Associate Director for R & D at the Electric Storage Battery Co.



"Why So Many Batteries?"

By HOWARD J. STRAUSS/Director, Research & Development
Burgess Battery Division, Clevite Corp.

There are almost as many different kinds of batteries as there are applications. Often the engineer needs help in deciding whether mercury, alkaline, or lead-acid cells best meet his needs.

IT wasn't too many years ago that battery manufacturers made only LeClanché cells (the type used to power flashlights) and lead-acid batteries for automobiles. There were some other electrochemical systems, such as nickel-iron (Edison) batteries for traction work, copper-oxide (Lalande) batteries for railroad signaling, and air depolarized cells for telephone and telegraph applications, and so on. But, by and large, these units had little commercial importance and were, even by contemporary standards, of rather simple design.

Burgeoning Business

But since World War II, the demand for new battery systems has skyrocketed and there have been significant engineering advances in some areas of battery manufacturing. But space, military requirements, and the needs of other modern electronic systems, have pushed the development of new batteries until today we are utilizing power devices that are literally out of this world. But the requirements grow still more demanding.

Battery manufacturers have indeed risen to this challenge and, in fact, we now have in commercial production a large variety of battery systems in various sizes and operational and environmental performances. As a matter

of fact, one of the big problems now is that there are so many batteries the electronics designer has difficulty in choosing the best unit.

Usually, the problem is compounded because the electronics engineer knows little of electrochemistry and is not in a position to make an independent choice.

Unfortunately, while many manufacturers have gone to the trouble of listing battery potentials, the proper choice of a battery supply often boils down to how the system acts under certain operating conditions. Basically, it's quite easy to calculate how much energy a battery must provide, and the power level at which this energy must be supplied. Most battery systems are able to provide almost any energy output at almost any power level since, after all, a suitable combination of cells in series and parallel will deliver the necessary voltage and current for any desired length of time. Determining which battery system to use is, therefore, the result of an intricate study of the second-order type of selection, namely, space and weight, environmental conditions, temperature and pressure, stress relationships, and so on.

In making his selection, the electronics designer should be intimately familiar with the conditions under which his apparatus (in this case, the power supply) is to work. Usually, however, it is late in the development cycle when the operational parameters are pinpointed. Thus, many electronics designers find themselves boxed in since the space and weight requirements may have been fixed without any consideration being given to the requisites of a particular battery-power source.

Selecting a Battery

It is best that electronics designers consider, right at the outset, the basic power source requirements and make a preliminary selection of a battery system which could be used in the equipment. To help the engineer, Table 1 lists sixteen fundamental cell characteristics which should be considered in the selection of a battery power supply. Some of these, such as energy per unit weight and energy per unit volume (Items 1 and 2 of the table) are fairly straightforward in that the electronics designer need only match the amount of energy required with space and weight limitations. Of course, the rate at which this energy is to be used is also of paramount importance, but the

Table 1. Fundamental cell characteristics.

1. High energy per unit weight
2. High energy per unit volume
3. High power capability (sustained)
4. High power capability (pulse)
5. Good shelf life or good charge retention
6. Good voltage regulation
7. High cycle life
8. Good high temperature characteristics
9. Good low temperature characteristics
10. Low cost
11. Minimal maintenance
12. Ease of storage and/or activation
13. High reliability
14. Good mechanical integrity
15. Pleasing appearance
16. Convenient availability

table does differentiate between sustained and pulsed power levels (Items 3 and 4). It turns out that batteries can deliver tremendously high power if they are required to provide such power only for extremely short duration. Thus, power loads must be broken down into sustained power and the power needed in short bursts. Generally speaking, power bursts of short duration may be 100 times that which the battery will sustain over a prolonged period of time. In other words, it's possible for low-power, long-life batteries to deliver tremendous power levels for extremely short durations.

Good shelf life or good charge retention (Item 5) is self-explanatory, but good voltage regulation (Item 6) requires some comment. Voltage regulation, as applied to batteries, is the property of delivering energy at constant voltage. Most batteries, in fact all of them with but one significant exception, have open-circuit voltages which are very much higher than their operating voltages. Thus, in electronics circuits which use multicell batteries, voltages are much higher at the beginning of the operating cycle than they are during the balance of the operating period. When the circuit is sensitive to the power-source voltage or when high initial power bursts are detrimental, this is a very important design consideration.

The remaining characteristics (Items 7 through 16) are all essentially self-explanatory. However, it should be pointed out that not all of these characteristics are of equal importance in every case. In the development of a flashlight, for example, the availability of a battery like that in Item 16 is of paramount importance. It wouldn't be to anyone's advantage to own a flashlight for which one had to ask a manufacturer to design a special replacement battery.

To help the electronics designer select the most suitable battery system, Table 2 lists the major commercially available battery types and rates them in terms of the sixteen fundamental cell characteristics of Table 1. A rating of "good", "fair", or "poor" has been assigned for each of the cell systems. For example, mercury cells are listed as "good" as far as energy per unit weight and volume, shelf life, and voltage regulation are concerned. In addition, mercury cells are quite good in that they require minimal maintenance and are easy to store. They also have high reliability and good mechanical integrity, are pleasing in appearance, and are conveniently available. On the other hand, they are only "fair" in their power output capability and their ability to withstand high temperatures, and are reasonably expensive. Therefore, when we consider the battery's pulse power capability and low temperature characteristics, mercury cells are not too impressive.

Needs vs Capacity

Naturally, the battery can be designed so that any one or several of these properties can be enhanced, but this is usually at the expense of some of its other capabilities. What is important is that this tabularized information represents an over-all summary, and to some extent opinion, of battery systems which the designer can utilize. However, the designer should remember that the tables represent only very general information and that the information can be considered biased under certain conditions. For example, what is high cost to one electronics designer may indeed be insignificant to another.

Current battery technology is receiving a great deal of academic and industrial attention. While battery suppliers have done a good job in providing designers of electronic (and other types of portable electrical gear) equipment with well-designed power sources, they have presented him with a perplexing array of batteries which require careful study. Considerable attention must be given to achieving a suitable balance between the available cells and their characteristics. ▲

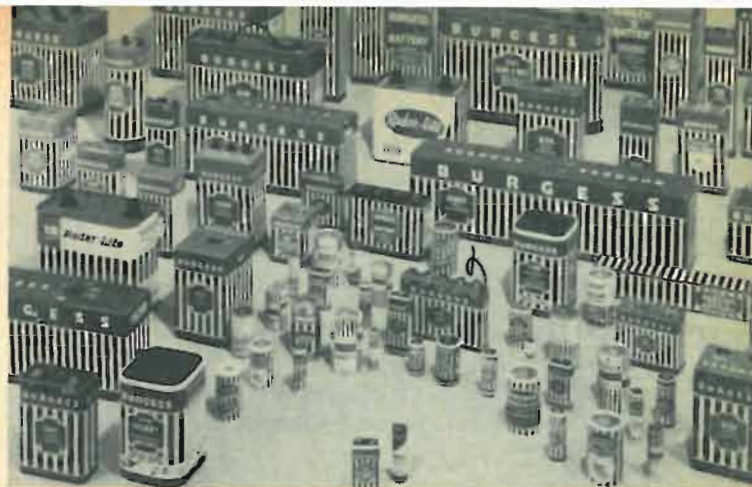

Table 2. Listing of commercially available battery types.

Type	Cell Characteristics Rating			
	Good	Fair	Poor	
Primary				
Carbon-zinc dry cell	1-5-10	6-8	2-3-4-9	
	11-12-13			
	14-15-16			
Alkaline dry cell	1-5-10	2-3-6-8	4	
	11-12-13			
	14-15-16			
Mercury	1-2-5-6	3-8-10	4-9	
	11-12-13			
	14-15-16			
Magnesium dry cell	1-2-5-6	3-4-7-8	10-13-16	
	11-12-14			
	15			
Air cell	1-2-11	5-6-8-12	3-4-9-10	
				13
Silver-zinc	1-2-6-11	13-16	5-10	
	12-14-15			
Caustic soda	1-2-6-11	5-8-10	3-4-9-14	
	12-13			15-16
Secondary				
Nickel-cadmium	1-3-4-5	2-6-8-10	15	
	7-9-11			
	12-13-14			
Lead-acid	2-3-4-7	1-6-11	5-12-15	
	8-9-10			13-14-16
Nickel-iron	5-6-7-11	1-2-3-8	4-10-15	
	12-13-14			9
Alkaline dry cell	5-8-10	1-2-3-4	6-7-9-13	
	11-12-14			
	15-16			
Silver-zinc	1-2-3-4	5-8-12	7-10-11	
	6-9			13-14
Silver-cadmium	2-4-5-6	1-3-7-8	11-15-16	
				9-10-12
				13-14
Reserve				
Silver chloride	1-2-3-4		10-15-16	
	5-6-8-9			
	11-12-13			
	14			
Cuprous Chloride	1-2-5-8	3-4-6-10	15-16	
	9-13			11-12-14
Silver-zinc	1-2-3-4	5-8-9-14	7-10-11	
	6-13			12-15-16
Thermal	5-8-9-10		2-3-4-6	
	11-12-13			
	14			15-16

The author received both his B.E.E. and M.E.E. degrees from New York University where he also engaged in research and teaching in the areas of control-system design and high-speed camera shutters. For the past seventeen years, he has been with Sorensen, working in power-supply design, development. He is former chairman of the Standards Committee of the NEMA Electronic Power Supply Group. He holds five patents in the power-supply field, has been a contributor to several engineering handbooks, and authored numerous published and unpublished reports and articles. He is a member of the IEEE, Tau Beta Pi, and Eta Kappa Nu.



A.C. Regulated Power Supplies

By PAUL MUCHNICK / Manager, Advanced Product Development Dept.
Sorensen Operation, Raytheon Co.

Characteristics of various types of regulators for a.c. power lines, including ferroresonant, saturable reactor, SCR, electromechanical, and fast-response.

AN A.C. SIGNAL may be defined in terms of amplitude, frequency, and phase. An a.c.-regulated power supply usually regulates only the amplitude parameter of the incoming a.c. line. If the power supply also regulates the frequency, then it must almost certainly mean that the input and output voltages are non-synchronous. Such devices are commonly referred to as *frequency-stabilized* power supplies.

The a.c.-regulated power supplies may be divided into two main categories, depending on whether or not the input and output frequencies are synchronous. Synchronous-frequency units are called *a.c. line voltage regulators*, *a.c. voltage stabilizers*, or *a.c. line conditioners*. These devices regulate the input line for peak, average, or r.m.s. amplitude, while retaining the frequency characteristics—but probably introduce a phase shift.

The non-synchronous types are called *inverters* when the device operates from a d.c. source or *frequency changers* when the input is a.c. There are specialized types of frequency changers whose inputs and outputs are har-

monically related: these sometimes carry the more descriptive terms *frequency doublers*, *triplers*, etc. This group of power supplies may be either self-excited or driven by a low-power oscillator.

The National Electrical Manufacturers Association (NEMA) recommends that commercial a.c. supply voltage should be maintained to $\pm 10\%$ constancy. Yet there are a great many applications where such variations are too great to provide either reliable performance or consistent and reproducible data. In addition, momentary and intermittent heavy loads cause even wider voltage variations that result in erratic performance and equipment malfunction. Even relatively small over-voltages will seriously reduce the life of incandescent lamps or many other devices that are connected to the a.c. line (Fig. 1).

To reduce or eliminate these problems, a.c. line regulators are installed in equipment, power benches or groups of benches, individual assembly lines, and entire plants. It is therefore not surprising that this type of regulator occupies a position of prime importance in the power-supply market.

The size of the a.c. line regulator market is as difficult to estimate as is the d.c. regulator market which has received considerably more attention. Bearing in mind that such estimates may vary by as much as 10 to 1, it is believed that the market for the electronically controlled static (non-mechanical) types is in excess of \$7 million per year with a relatively shallow growth of less than 10% a year. The market for ferroresonant a.c. regulators is possibly half this size.

The Variety of Designs

These a.c. line regulators are made in a great variety of electrical and mechanical designs for an extremely broad range of applications. The various designs include: 1. ferroresonant regulator, 2. electronically controlled saturable-core reactor regulator, 3. silicon controlled rectifier regulator, 4. electronically controlled electromechanical regulator, and 5. the amplifier or fast-response regulator.

These types are available in capacities that range from as low as 15 VA in ferroresonant types to several hundred kVA for electromechanical types. Still larger capacities are available in induction and tap-changing types. The output voltage settings of regulators may be fixed, or adjustable over either narrow or wide limits. The acceptable range of input frequency is generally relatively narrow with degeneration of setting, regulation, and harmonic

Fig. 1. With just a 10% over-voltage applied to incandescent lamps, life expectancy is only about 30% of the rated value.

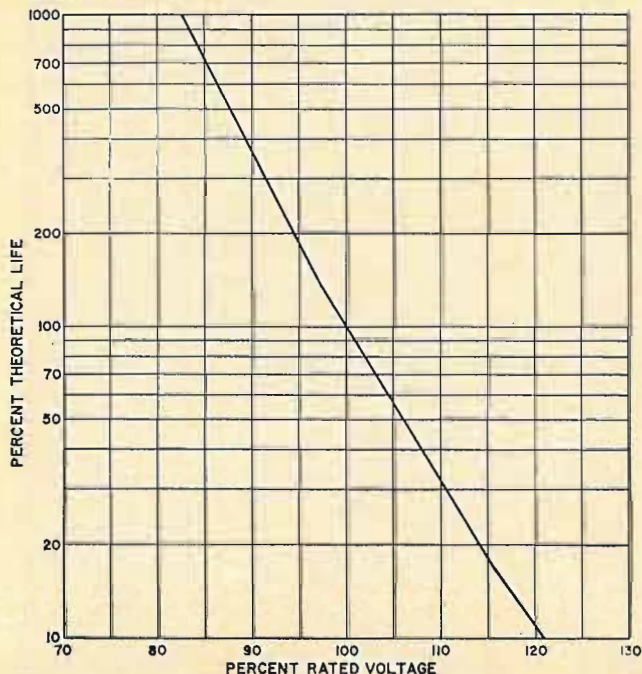

distortion occurring around a nominal value. Percent regulation can vary over the extremely wide range of better than 0.01% for line and load to almost 10% for load. Speed of response varies from microseconds to a full second response. Output distortion is another important parameter. Some units introduce considerable amounts of distortion such as peak clipping or other non-linearities resulting from the use of saturable-core inductors, while others operate on the incoming waveform to actually filter out harmonics.

1. *Ferroresonant Regulator*: The constant-voltage transformer or ferroresonant regulator is a relatively simple open-loop regulator depending solely upon saturation of iron-core material for regulating action. They are extremely economical and reliable, and are self-protecting for overloads in that short-circuit current is limited to about 200% of rating. They have no moving parts or external adjustments.

While this type of regulator is excellent for fixed loads that do not require extremely rapid response (e.g., filament power), it has some disadvantages. The saturation of some of its components results in considerable distortion of the output-voltage waveform (*unless special low-distortion types are used—Editor*), load regulation is generally poor, and output voltage setting is heavily dependent on input frequency.

The equivalent circuit for the regulator is shown in Fig. 2A. $L1$ and $L2$ are linear chokes while $L3$ is self-saturating. The $L3-C1$ combination has a current-voltage relationship as shown in Fig. 2B. Over the region A-B (on the curve of total shunt current) this network draws a capacitive current that produces a drop across $L1$ of such a polarity as to make E_o greater than E_i . Over the region B-C the current drawn is inductive, resulting in E_o being smaller than E_i . This correction is by no means perfect, so a compensation winding $L2$ coupled to $L1$ is added to the circuit to improve its operation.

The output voltage level of this regulator may be varied by several means. These include: variation of $L3-C1$ product; variation of turns or the amount of iron used in $L3$; and variation of core material of $L3$. A variation in the impedance of the linear chokes will shift the input operating range.

Special ferroresonant designs with low harmonic distortion are available, but other characteristics may suffer.

2. *Electronically Controlled Saturable-Core Reactor Type*: The circuit in Fig. 3A is typical of the basic design of this closed-loop regulator. Regulated output is obtained by controlling the d.c. current through the control winding of the saturable-core reactor, thereby varying its inductance. The result is that corrective voltages are produced at the autotransformer which add or subtract vectorially from the input voltage. The entire closed-loop system consists of an r.m.s. voltage detector on the output, comparison to a reference, generation of an error signal, and amplification to generate reactor drive power. Since the circuit is non-linear in operation, distortion is generated in the system. This is reduced by the addition of harmonic filters across the autotransformer. Only odd-harmonic filters are required.

This regulator has a response time of 0.02 to 0.15 second. Its output setting is only slightly affected by frequency, and line and load regulation can be 1 or 2 orders of magnitude better than the ferroresonant type. The output is easily adjustable. Disadvantages include, in addition to the 3% or 4% of generated harmonic distortion, an appreciable phase shift that varies with line and load setting.

3. *Silicon Controlled Rectifier Regulator*: These regulators are all-solid-state versions of the saturable-core reactor type just described. The major difference is the substitution of SCR's for reactors. Inasmuch as the SCR

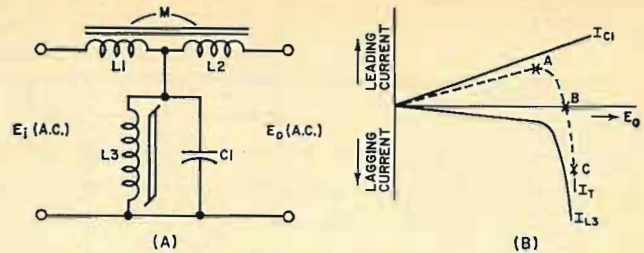

Fig. 2. (A) Equivalent circuit of constant-voltage transformer or ferroresonant regulator. (B) Current-voltage characteristics of the shunt components $C1$ and $L3$ used.

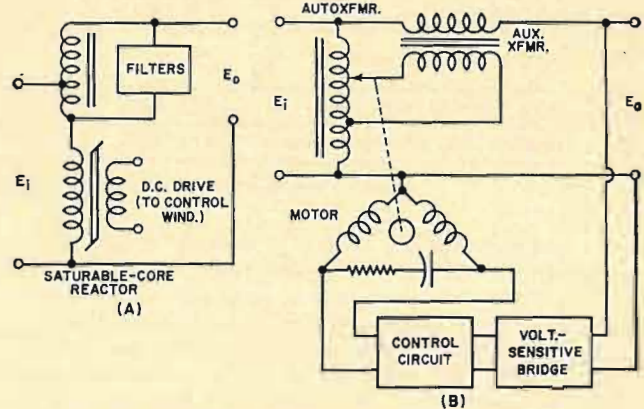

Fig. 3. (A) Autotransformer-reactor regulator. (B) Electro-mechanical regulator uses motor-driven autotransformer.

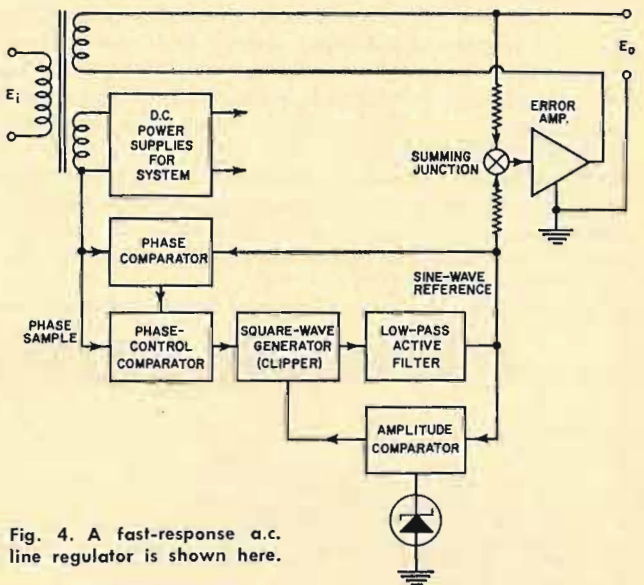

Fig. 4. A fast-response a.c. line regulator is shown here.

is not as rugged as the reactor for overloads, this regulator usually has an over-current protection system included in the form of special protective circuitry and/or fuses. The temperature-limited vacuum-diode r.m.s. detector used in saturable-core systems is replaced by a solid-state detector which may not perform as well, so performance may suffer in some areas (e.g., E_o vs frequency). In the larger sizes, these units are less expensive, more reliable, and smaller than the previous design.

4. *Electronically Controlled Electromechanical Regulator*: The simple design philosophy of this buck-boost system yields a regulator that produces almost negligible distortion and phase shift, insensitivity to frequency, and very high efficiency. The disadvantages are slow response and recovery time, rather poor regulation of 1% to 2%, and some maintenance required due to moving parts and contacts. Economic advantages over the SCR type units appear only above 5 to 10 kVA levels. The unit consists

	Ferroresonant	Saturable Reactor	SCR	Electro-mechanical	Fast-Response
1. Regulation—line	1%	.01-.2%	.1-.25%	1-2%	.1-1%
2. Regulation—load	1-5%	.01-.2%	.1-.25%	1-2%	.1-1%
3. Distortion, output	20%	3%	3-5%	Negligible	.25-5% max.
4. Temp. Coefficient	.03%/°C	.01-.03%/°C	.01-.03%/°C	----	.01-.03%/°C
5. Efficiency	82-93%	82-92%	85-95%	95-99%	60-75%
6. Response Time	.02-.07 s	.02-.15 s	.02-.15 s	.02-.4 s/volt	50-100 μ s
7. Capacity	.015-10 kVA	.25-15 kVA	.5-15 kVA	2-200 kVA	.5-5 kVA
8. Output Adjustability	No	Yes	Yes	Yes	Yes
9. E_o vs Frequency	1%/Hz	.03-.05%/Hz	.03-.05%/Hz	None	.01-.03%/Hz
10. Distortion vs Frequency	---	6-8% for 10% off nominal frequency		None	---
11. Cost: (\$/VA)/unit size	.12/1 kVA	.34/1 kVA	.36/1 kVA	.08/6 kVA	1.40/1 kVA
12. Weight: (lbs/VA)/unit size	.08/1 kVA	.08/1 kVA	.05/1 kVA	.02/6 kVA	.1/1 kVA

Table 1. Summary of the most important characteristics of the a.c. line regulators described here.

of a voltage-sensitive bridge, a control circuit, and a motor-driven variable autotransformer (Fig. 3B). The system is quite easily adapted to three-phase regulation by mounting three autotransformers on a common shaft.

5. *Fast-Response Regulator*: These units use vacuum-tube or solid-state amplifiers to add to or subtract power from the incoming a.c. line. They have very fast reaction time, approaching 50 μ s, hence the ability to not only regulate r.m.s. levels but reduce incoming harmonics by acting as a filter.

A typical block diagram of such a regulator is shown in Fig. 4. A sample of the input voltage first has its phase compared to the sine-wave reference and corrected to an 180° out-of-phase condition. It is then squared and clipped to develop a symmetrical square wave. The amplitude is kept constant. Filtering then follows to produce a stable, pure a.c. sine-wave reference signal. This reference and the output are compared and the error is amplified to correct the output level. Regulators of this type are most advantageous where incoming transients or dis-

ortion is great enough to affect measurements adversely.

A summary of the characteristics of the various a.c. line regulators is given in Table 1.

Non-synchronous power supplies generate their output by first rectifying the input power and then applying the resultant d.c. to some type of power oscillator and/or amplifier. These systems are discussed in other articles in this Special Section. Regulation schemes include high-gain feedback amplifiers; r.m.s. detection of the output to control the d.c. voltage level feeding the inverter; and controlled variable loads, such as SCR's, on the output of the power supply.

The generation of three-phase regulated voltage is a particularly interesting problem. Because of the variable nature of phase shift through the inverters (due to changes in line and load), two voltages are usually generated and regulated. A third circuit regulates the phase angle between them. The third output voltage is generated by adding these two voltages and shifting the resultant by 180 degrees. ▲

POWER-SUPPLY MODULES

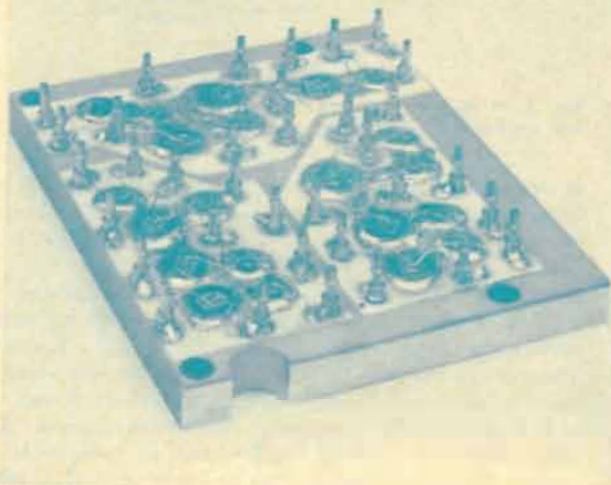

Fig. 1. Hybrid assembly of a stepping motor-drive power supply. The three light sections are an aluminum-oxide coating over a metallic substrate. Copper is flame-sprayed on the oxide to form a mounting surface for the active elements. Radiators are not used.

HI-PAC (high-density packaging), developed by Solitron Devices, is a method of coating metallic substrates with aluminum-oxide to provide a low thermal resistance path. Copper is flame-sprayed on the aluminum-oxide surface to form a base for electrical interconnections. The result is a system with a high built-in heat-sinking potential. In addition, the process greatly facilitates multilayering, through-hole connections, and around-the-corner circuitry.

The copper surface is ideal for mounting chip components because it eliminates the need for stud bases and transistor cans as heat dissipators. The thermal resistance of the mounting board, from chip to substrate, is less than 0.7° centigrade per watt and the dielectric insulation is rated at 500 volts per mil.

As an example of what is attainable with the Hi-Pac process, a power hybrid assembly for a stepping motor-drive power module is shown in Fig. 1. Each of the three sections contains a Darlington pair (5-ampere transistor driving a 20-ampere device) and another 5-ampere unit to supply motor field current. Each section is step operated at a peak current of 17 amps and an average current of 8 amps, at 80 volts d.c. Each section also dissipates 48 watts (120 watts peak). The assembly, less components, is about 3½ x 3½ x ¾ inches—a very small package for the high power rating of the module.

Most Hi-Pac power modules have been developed for special customer applications. In the near future, however, Solitron expects to develop a standard line of hybrid power modules. ▲



The author received his MEE from Polytechnic Institute of Brooklyn in 1952. His major field of interest has been in solid-state control and servo systems. He has developed various d.c. and a.c. power conditioners for military and aerospace use. He is now Director of Research and Development for Cox & Co.

Power Inverters and Converters

By BENJAMIN BARRON/former Director of Engineering
Data and Controls Div., Lear Siegler, Inc.

Guidelines in selecting and specifying the proper d.c. to a.c. inverter and d.c. to d.c. converter, along with precautions in using and designing these sources.

A POWER inverter or converter converts d.c. to a.c. at some point in its operation. The power inverter delivers an a.c. output that is either sinusoidal or some type of switched wave. The power converter, usually called a "d.c. to d.c. converter", converts d.c. to a.c., transforms the resultant a.c. voltage to another level, and then rectifies and filters the waveform to produce a new d.c. voltage, differing in value from the input d.c.

The inverter may also be used to convert a.c. from one frequency to another. In this case, the input a.c. is first converted into d.c., usually by rectification; then the d.c. is converted into a.c. of another frequency, which is used as output.

Before the advent of power transistors and silicon controlled rectifiers, methods for converting d.c. to a.c. were mechanical, either through the use of mechanical vibrators, motor-generator sets, or power vacuum tubes, thyratrons or ignitrons. Most of these systems were characterized by short life, unreliability, or inefficiency. With the advent of aerospace programs, the need for lightweight, efficient inverters developed. The solid-state or *static inverter* came into being and has since found application in many other areas.

The most commonly used solid-state devices are SCR's or switched power transistors acting as the power converting elements. This article deals exclusively with circuits using these devices.

Applications of Inverters, Converters

In the missile and satellite fields, static inverters are used as precision a.c. supplies for gyroscopes, accelerometers, synchros, servo controls for guidance and attitude controls, and synchronous motors for timing. In military or industrial areas, static converters are used for: battery or fuel cell-powered emergency supply to critical systems in the event of power-line failure; sonar transducer and driver supply; antenna spinner supply; precision a.c. power for remote clocks; frequency changers for operation of high-speed machine tools; a.c. sources for automotive and marine use; and high-frequency a.c. lighting from d.c. or low-frequency sources.

D.c. to d.c. converters are used in missiles and satellites for the conversion of d.c. to one or more isolated levels to be regulated and conditioned in order to power delicate controls and sensing systems. Large converters are used for solar-powered ion engine drives. In military or industrial areas, converters are used for high-frequency,

lightweight, high-efficiency power supplies; for portable battery-powered equipment; and in fuel-cell converters and regulators. Converters are used to permit battery operation of portable electronic devices, such as television systems, instruments and recorders, and miniaturized computers and displays.

Operating Characteristics & Circuit Designs

Silicon controlled rectifiers and transistors, when used in the switching mode, have three inherent characteris-

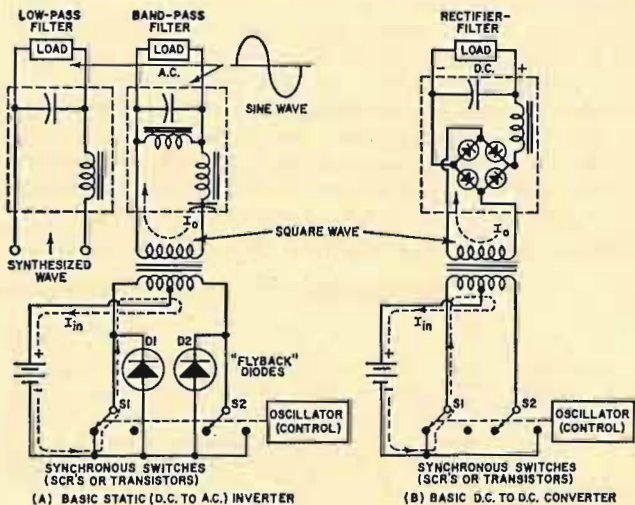
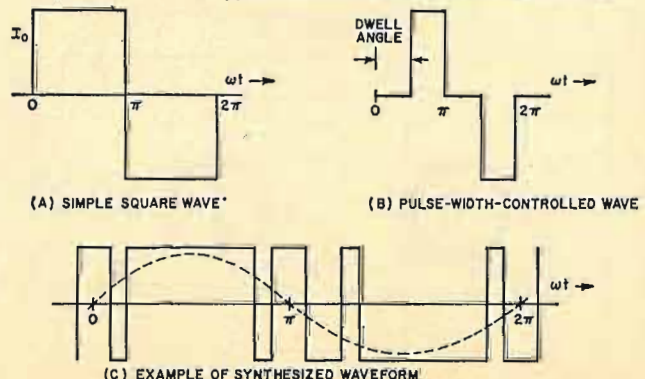

Fig. 1. Basic configurations of (A) inverter and (B) converter. Direction of electron current flow is indicated by dashed arrows.

Fig. 2. A number of typical switched waveforms are shown here.



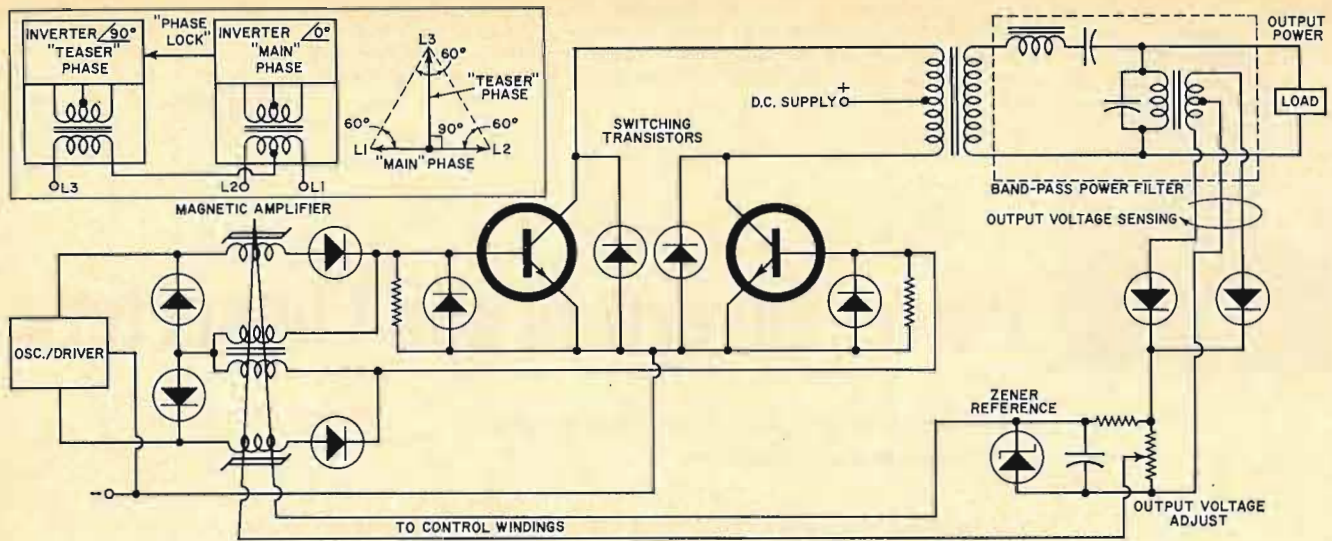

Fig. 3. Simplified schematic of single-phase, pulse-width-controlled inverter with regulation and sinusoidal output. Inset circuit shows how two such inverters can be employed to produce 3-phase output.

tics that make them suitable for use in the static inverter and d.c. to d.c. converter. They have very low resistance when turned "on" (low forward drop), very high impedance when turned "off" (low leakage), and they change state very rapidly. These characteristics result in high conversion efficiency and good load regulation. High reliability is inherent because static inverters and converters have no moving parts, they require no high-temperature heaters in their operation, and the semiconductors are mechanically rugged. Properly designed units, with sufficient protection systems built into them, can stand abuse and mishandling. It can be assumed that they will outlast the systems they are powering.

Both the static inverter and converter use semiconductors as switching elements to alternately connect a load to a d.c. source. Fig. 1 shows the basic configuration.

S_1 and S_2 represent switching transistors or SCR's that are driven from an oscillator. As can be seen, the input current, I_{in} , is first connected to one half of the transformer primary and then to the other. As a result of this action, the output current from the transformer I_o , keeps alternating its polarity in synchronism with the driving source

oscillator. S_1 and S_2 may be simply switched "on" and "off," with 180° duty cycle, to produce a simple square-wave output. Control of the output can be accomplished by delaying the action of the switches so that the second switch does not come on immediately after the first is turned off. The period of time that is delayed is called the "dwell angle", as is shown in Fig. 2.

When a sinusoidal output is required from a static inverter, the resultant square wave can be fed through a passive band-pass filter. Other methods are used to produce sinusoidal waveforms. For instance, S_1 and S_2 can have multiple switch actions to produce the quasi-square waveform of Fig. 2C. This is then applied to a low-pass filter. The flyback diode is used here since it is essential to provide a path for reactive current back to the d.c. source. Such current will occur when the load is reactive. Since the current cannot flow back through the SCR's or switching transistors when their anode or collector voltages are reversed, an alternate path must be provided through the diodes.

In the case of the d.c. to d.c. converter, the square wave is rectified and filtered. If simple pulse-width

Fig. 4. Self-oscillating d.c. to d.c. converter followed by a dissipative pass regulator and "loss-less" regulator.

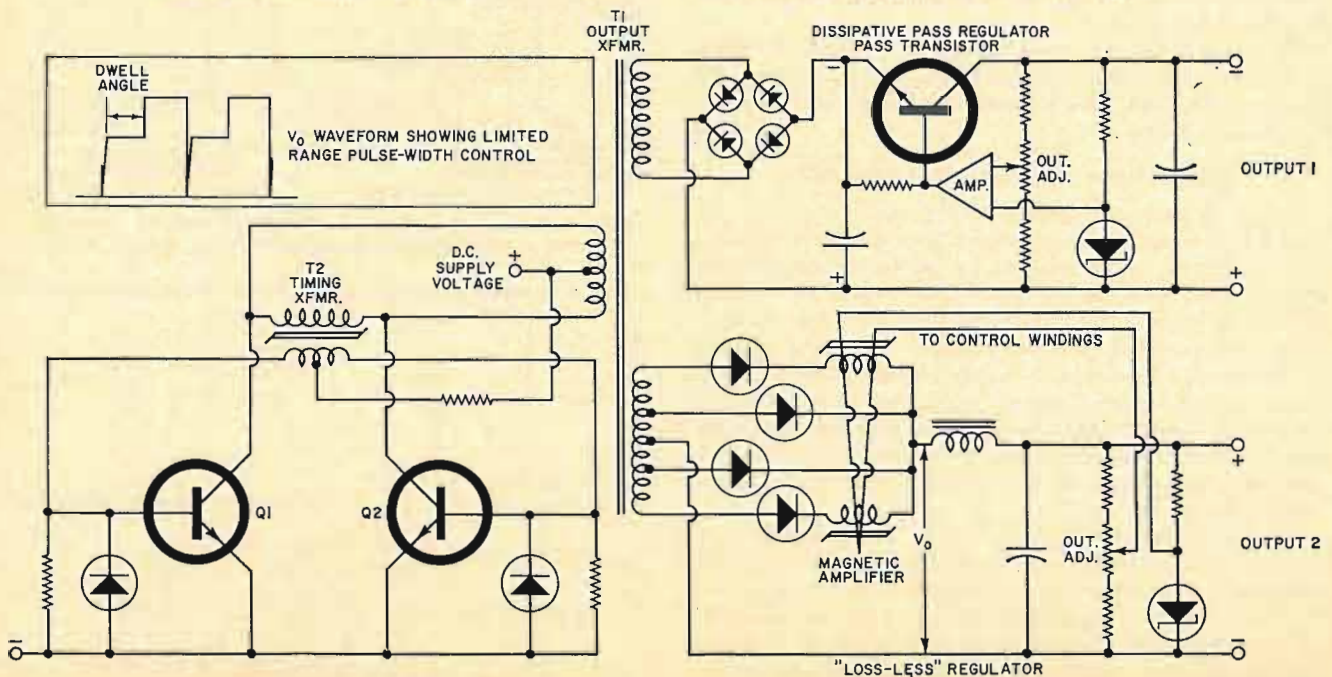

power control is used, a choke input filter is required.

Fig. 3 is an inverter for aircraft and missile application. A nuclear-radiation-hardened version is shown on the cover of this issue. The power transistors are switched "on" and "off" by base-to-emitter voltages generated by the oscillator-driver. Magnetic amplifiers are provided in the base circuits of the pair of switching transistors. In this manner, the transistor switching as well as the dwell angle are controlled from a single source. The amount of dwell angle is controlled by output voltage feedback to the zener diode circuit in order to provide the desired output-voltage regulation. The resultant pulse-width-controlled wave is filtered to produce a sine-wave output at the load.

It was further desired to obtain three-phase power. To accomplish this, two similar inverters are used and phase-locked 90° apart. By suitable interconnection using the "Scott T" configuration, the two phases are combined to produce three phases.

Fig. 4 shows a self-oscillating d.c. to d.c. converter followed by two kinds of post regulators. Timing transformer T_2 is designed to saturate readily. The phasing of this transformer is such that the secondary feeds back positively to the bases of Q_1 and Q_2 . The frequency of oscillation is governed by the number of turns, the magnetic properties of the core material of T_2 , and the value of line-voltage input.

Output #1 is used where d.c. with precise voltage regulation and low output impedance is required. For precise regulation with limited range for the output impedance characteristic, a "loss-less" stepped-wave controller is used (output #2). The dwell angle produced by magnetic amplifier control over a limited range produces the stepped waveform shown. This type of operation reduces the amount of output filtering required and thus optimizes the response attainable from the pulse-width controller. The output is sensed and compared to the reference zener diode and fed back to the control windings of the magnetic amplifier to accomplish the desired voltage regulation.

Important Precautions

There are certain precautions to be followed when applying inverters and converters to systems.

1. *Adequate cooling:* Often the user is vague as to the actual method he intends to use to remove heat from the unit. Some method must be decided upon long before the

system is installed. Conduction cooling is done by bolting the device to a surface from which the heat will be removed in some manner (such as with a heat sink). Thermal characteristic in degrees rise per watt of dissipation into the heat sink must be known and taken into account. If self-cooling is contemplated, determine if convection cooling is adequate. For inverters over 100 watts, it is usually not adequate. Cooling by radiation is usually useless. If fans are to be used, it should be noted that cooling decreases rapidly with altitude. It is best to select the fan for the maximum altitude condition.

2. *D.C. input lines:* Such lines are usually highly reactive. Contrary to the usual assumptions, batteries and d.c. generators are not low-impedance sources for high frequencies. Furthermore, the inductance of the power line between the d.c. source on the unit is not negligible. The power-switching elements pull current from the power line in surges at twice the output frequency. This can give rise to damaging transient voltages on the unit input. In almost all installations, a large capacitor should be included across the d.c. input terminals of the inverter or converter. Often, it is best to build the line-stabilizing capacitor directly into the unit.

3. *Germanium vs silicon transistors:* Except for low-voltage applications, always use silicon power switching transistors.

4. *Grounding:* Power switching devices are electrically noisy. They are usually a.c.-coupled to the chassis through the capacitance of the heat-sink insulator and through transformer and wiring magnetic fields. Consequently, short-duration pulse voltages, called "needles", tend to appear in the outputs of d.c. to d.c. converters. If at all possible, ground the systems to the converter itself. This is very important when the intended use for the d.c. to d.c. converter is for high-speed digital circuits. Grounding at the converter will greatly reduce these disturbances.

5. *Skill of personnel:* It is obvious that as the skill of personnel decreases, the chances for mishandling and thus damaging the units increase. This should be taken into account. Careful attention should be given to the specification of the protection systems that must be built into converters and inverters for such use.

6. *System discipline:* Because of habit, sinusoidal sources are often specified for transformer-rectifier power supplies, the sinusoidal power being produced by a static inverter.

Table 1. Performance characteristics of static inverters with a wide range of inputs and outputs.

INPUT D. C. VOLTAGE RANGE	OUTPUT VOLT/ AMP	RANGE OF OUTPUT VOLTAGE	OUTPUT WAVE-FORM	OUTPUT FREQ. RANGE	NUMBER OF PHASES	TYPE OF SWITCHING ELEMENT	EFFICIENCY (%)
1 to 12	1-200	24 to 220	Sinusoidal	50-3200 Hz	1,2,3,6,etc.	Germanium Transistor	60-85
			Square	50-3200 Hz	1 or 3	Germanium Transistor	70-92
12 to 250	1-3000	24-1000	Sinusoidal	50-1500 Hz	1,2,3,6,etc.	Low-speed Silicon Transistor	60-85
				1500-50,000 Hz	1,2,3	High-speed Silicon Transistor	60-85
			Square	50-1500 Hz	1 or 3	Low-speed Silicon Transistor	70-92
				1500-50,000 Hz	1 or 3	High-speed Silicon Transistor	70-92
150 to 500	2500-up	115-2500	Sinusoidal	50-1000 Hz	1,2,3,6,etc.	SCR	60-80

If the ultimate need for the a.c. is for a set of d.c. supplies, either produce the various d.c. levels directly within the d.c. to d.c. converter or supply a preregulated square wave to the a.c. distribution system. Maintain control of the d.c. levels required for the circuits being designed by various engineers for later integration into an over-all system. Lack of design discipline usually results in the creation of unnecessarily complex power systems. Multiple-output d.c. to d.c. converters, with the necessary output characteristics, often become nearly as complicated as the systems they are powering. Their cost becomes a significant percentage of the over-all system cost. Whenever possible, the systems manager should specify a minimum number of available d.c. levels before circuit design commences.

7. *Specifying*: Do not overspecify the output power of inverters or converters. It is a common error for users to assume that an inverter or converter will run much cooler when operated at reduced loading. Losses in a properly designed device vary from about 1.5 to 1 in going from full load to no load. Safety factors are put into the devices when originally designed. Do not call for more accuracy or less distortion than is actually required for the system. Proper specifications result in savings of power, weight, and cost.

Guidelines for Specifying

The following is a list of the critical parameters that should be included when selecting or specifying static inverters (see Table 1) or d.c. to d.c. converters.

A. Output—Static Inverter

1. *Volt-amps*: Minimum, maximum
2. *Power factor variation*: Minimum, maximum
3. *Output frequency*: Minimum, maximum. Stability with line, load, temperature, time.
4. *Phase*: Number needed, tolerance with load unbalance, phase stability with line, load, temperature.

5. *Output waveforms*: Square: Rise, fall times, flatness, symmetry. Sine: Distortion in percent, maximum percentages for various unwanted harmonics, crest factor.

6. *Transient response*: Line, load steps.

B. Output—D.C. to D.C. Converter

1. *Number of outputs required*: Isolation between outputs to ground.
2. *Output voltage*: Variation of set-point stability with line, load, temperature, time.
3. *Output current*: Minimum, maximum, ripple content, step variation.
4. *Ripple, noise*: Maximum in peak-to-peak. Bandwidth to be observed.
5. *Transient response*: Line, load steps, overshoot, undershoot, and recovery time.

C. *Input D.C. Line Voltage*: Minimum, maximum, transient surges, line impedance for various frequencies allowable, reflected noise from the inverter back to the line (See the appropriate MIL-Spec, if it is given.)

D. *Mechanical*: Size, weight, required shape, connectors.

E. *Protection*: Overload, short-circuit, over-voltage, reverse voltage, over-temperature.

F. *Available Cooling*: Self-convection, heat sink, fan or air blast, liquid. Define the method.

G. *Environment*: (See MIL-Spec, if given.)

1. *Temperature*: Maximum, minimum operating and storage. Allowable warm-up time.
2. *Shock*: Impulse height, shape, time duration, number.
3. *Vibration*: Sinusoidal, amplitude *vs* frequency, duration at various frequencies and axis.
4. *Random*: Bandwidth, spectral content.
5. *RFI, EMI*: (See MIL-Spec, if given.) Limits of conducted, radiated for various test frequencies.
6. *Altitude*: Temperature *vs* altitude. ▲

POTENT POWER PACKS

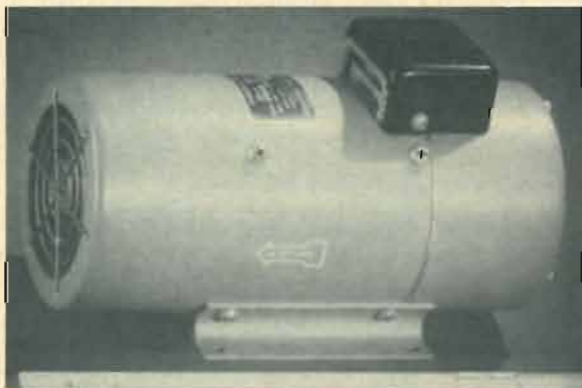

reducing the size of power packs is the Tung-Sol Division of Wagner Electric Corp.

The 100-ampere ground power (GP) supply in the photograph is ultra lightweight and compact; it weighs less than eight pounds and is only 8½" l. x 4" w. x 5⅛" h., although it handles more power than some units twice its size.

Physically, the ground power unit is similar to the airborne version. The cylindrical housing and circular heat sinks, which are constructed of rigid extruded aluminum, enable the power supply to be mounted in any position. An internal blower and a modified pressure cooling system is used to dissipate heat.

Basically, the circuit is a double-Y delta transformer with silicon rectifiers which operate from a 120/280-volt, 400-Hz, 3-phase a.c. input. Original equipment manufacturers can obtain ground power units having outputs of 28 volts at 100, 200, 300, and 400 amps. Twenty-eight-volt airborne units are available with output currents of 50 to 200 amps. A similarly constructed 60-Hz, 50 to 200 amp unit for portable field use will be introduced.

Communications equipment manufacturers who prefer rack-mounted supplies can use the CR 27.5 series of high-current d.c. units. These solid-state controlled magnetic amplifiers were developed especially for marine single-sideband systems. They have a highly regulated (better than 1%) voltage output of 27.5 V and currents of 25 to 150 amps, and operate from a 50/60 Hz line.

It is the package that counts, in the air and on the ground. The problem with most high-current power conversion equipment is that it is bulky, heavy, and hard to manage. In airborne systems particularly, power units often take up most of the available equipment space. One of the companies specializing in

If it's modules the equipment manufacturer needs, he might try the LC solid-state power packs developed by Electronic Research, Inc. There are five models which cover current ranges of 0-750 mA, and 0-1, -2, -5, and -10 amperes. Each individual module can be set to any desired output voltage in the 4-32-volt d.c. range.

The LC modular power packs incorporate special circuitry to take full advantage of the properties of silicon semiconductors. The regulator is a silicon transistor emitter-follower circuit in series with the rectified and filtered d.c. source. The series regulator is controlled by a feedback amplifier loop which is referenced to an independent constant voltage source. Changes in the output voltage caused by load variations are compared with the constant voltage source and amplified error signals control the emitter-

follower in such a manner as to compensate for the load and line changes. In order to obtain the sensitivity necessary to provide closed-loop regulation, stabilized gain stages are utilized in the feedback loop. The sensing source at the output of the regulator is a bridge circuit with one of its arms containing the constant-voltage reference. The referenced voltage is, in turn, provided by an independently controlled zener diode.

The modular supplies range from 4" x 4" x 6½" h. to 8¾" l. x 9½" w. x 7¼" h. The a.c. input and d.c. output connections are made to terminal strips. Voltage and current adjustments are made on transformer voltage taps and slotted screwdriver adjustments. All models operate at 105/125 Hz, but 400-Hz operation is available by means of a simple tap adjustment. ▲

The New 1968 Improved Model 257 **A REVOLUTIONARY NEW**
TUBE TESTING OUTFIT

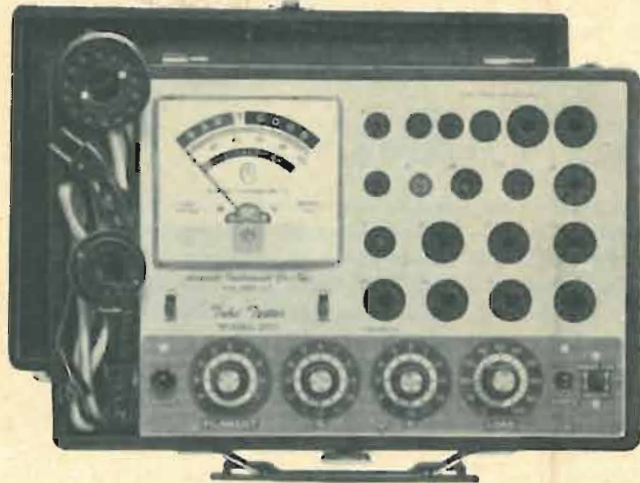

**COMPLETE WITH ALL
 ADAPTERS AND ACCESSORIES,
 NO "EXTRAS"**

STANDARD TUBES:

- ✓ Tests the new Novars, Nuvistors, 10 Pins, Magnovals, Compactrons and Decals.
- ✓ More than 2,500 tube listings.
- ✓ Tests each section of multi-section tubes individually for shorts, leakage and Cathode emission.
- ✓ Ultra sensitive circuit will indicate leakage up to 5 Megohms.
- ✓ Employs new improved 4½" dual scale meter with a unique sealed damping chamber to assure accurate, vibration-less readings.
- ✓ Complete set of tube straighteners mounted on front panel.

BLACK AND WHITE PICTURE TUBES:

- ✓ Single cable used for testing all Black and White Picture Tubes with deflection angles 50 to 114 degrees.
- ✓ The Model 257 tests all Black and White Picture Tubes for emission, inter-element shorts and leakage.

COLOR PICTURE TUBES:

- ✓ The Red, Green and Blue Color guns are tested individually for cathode emission quality, and each gun is tested separately for shorts or leakage between control grid, cathode and heater. Employment of a newly perfected dual socket cable enables accomplishments of all tests in the shortest possible time.

The Model 257 is housed in a handsome, sturdy, portable case. Comes complete with all adapters and accessories, ready to plug in and use. No "extras" to buy. Only

\$47⁵⁰

NOTICE

We have been producing radio, TV and electronic test equipment since 1935, which means we were making Tube Testers at a time when there were relatively few tubes on the market, way before the advent of TV. The model 257 employs every design improvement and every technique we have learned over an uninterrupted production period of 32 years.

Accurate Instrument Co., Inc.

SEND NO MONEY WITH ORDER
PAY POSTMAN NOTHING ON DELIVERY

Try it for 10 days before you buy. If completely satisfied then send \$10.00 and pay the balance at the rate of \$10.00 per month until the total price of \$47.50 (plus P.P., handling and budget charge) is paid. If not completely satisfied, return to us, no explanation necessary.

ACCURATE INSTRUMENT CO., INC.
 Dept. 559 2435 White Plains Road, Bronx, N. Y. 10467

Please rush me one Model 257. If satisfactory I agree to pay \$10.00 within 10 days and balance at rate of \$10.00 per month until total price of \$47.50 (plus P.P., handling and budget charge) is paid. If not satisfactory, I may return for cancellation of account.

Name _____
 Address _____
 City _____ Zone _____ State _____

Save Money! Check here and enclose \$47.50 with this coupon and we will pay all shipping charges. You still retain the privilege of returning after 10 day trial for full refund.



JOHN FRYE

Present developments foretell the use of very sophisticated electronics equipment in future agricultural operations.

ELECTRONICS AND FARMING

“AND now, farm friends, we bring you the latest livestock quotations,” a voice announced from the little radio Barney was putting back in the case. “Oh no you don’t!” Barney retorted as he snapped off the switch. “If there’s one thing on the radio I can’t stand,” he explained to Mac, his employer, “it’s that stuff. I wonder if anyone really listens to it.”

“You can bet if they didn’t it wouldn’t be on the air,” Mac answered. “That program is every bit as interesting to farmers as stock market quotations are to investors in stocks and bonds. In fact, programs such as these coming in forty years ago over battery-powered *Atwater Kent* receivers or *Crosley Fivers*’ first revealed to farmers what a valuable ‘hired hand’ electronics could be.”

“Big deal!” Barney scoffed. “Farmers are too old-fashioned and set in their ways to take advantage of anything as new as electronics. Now, forty years later, about the only new uses a farmer makes of electronics is to charge his electric fence, to control the automatic security light in his barnyard, and to act as an electronic dinner bell—*via* a CB rig installed on his tractor—so the little woman can call him when soup’s on.”

“I hope you like the taste of those words,” Mac said, grinning, “because you’re going to have to eat them. It just so happens I’ve been reading lately of some exciting developments in agricultural electronics; and, since I’m the master and you’re the slave, you’re going to have to listen to them.”

“Yes, Master; anything you say, Master,” Barney replied with mock subservience.

“Professor L. M. Eisgruber, Department of Agricultural Economics, Purdue University, is especially interested in harnessing computers to work for the farmer; and I learned a great deal from a paper entitled ‘A Look at the Horizons’ presented at *The Conference on Computer Technology—a Farm Business Management Tool* held at Kansas State University in May of last year. He also published an article entitled ‘Micro- and Macro-Analytic Potential of Agricultural Information Systems’ in the December, 1967, issue of the *Journal of Farm Economics*.”

“While I’ll cheerfully admit much in these papers was over my head, they made me realize something we city-slickers are prone to forget. A modern farm is actually a ‘farm factory’ which represents a very substantial investment of capital, which produces a wide variety of products, which operates in a keenly competitive market, which is unusually sensitive to the vagaries of the weather, and which is plagued by all the problems of any other manufacturer: obtaining sufficient operating labor and capital, keeping raw material and production costs down, finding the best-paying markets for the products, etc., etc.”

“Now no conventional manufacturer would dream of trying to operate his business without the help of such information aids as a carefully prepared budget, cost analysis, time-and-motion studies, market research, quality control, research and development, and a tax accounting department. But the independent farmer is likely to struggle

along without any data or records other than those that the Internal Revenue Service demands that he keep. It is not that he would not like to know more about how his operation is doing; it is simply that he is so busy swapping the many hats he must wear—manager, purchasing agent, laborer, financier, machine operator, bookkeeper, and marketing director—that he does not have the time to collect the data and process it into the information he needs for making decisions. Neither, in most cases, does he have the proper education for this job. As a result, many farm operations are conducted on a ‘by guess and by gosh’ system that simply isn’t good enough to let them compete against the big business methods of the large syndicate-owned farms.

“Providing the farmer with access to a large computer on a time-sharing basis is the answer. The computer must be large because many of the farm problems are complicated. But the small farmer does not need to own a computer any more than he is forced to own a generating plant to obtain electricity. All he will need pay for is a terminal at his home, the use of a communications line to the computer center, and the amount of computer time he actually uses. Communication to and from the computer will be provided by means of a special typewriter, or an optical or magnetic scanning device may ‘look’ at a single sales slip for cow feed and feed information over a network of computers into the total farm account, an enterprise account, the feed dealer’s account, and the farmer’s bank account.

“But the computer will do far more for the farmer than merely perform his bookkeeping or provide him with information for filling out his income tax form. Since the computer’s memory will be stored with data from thousands of other farms, the individual farmer can compare his own operation with that of his competitors and see where he is making mistakes. The computer will keep track of the performance of his dairy herd and tell him which cows are delivering the most milk, what feed is giving the best results, and which cows should be removed from the herd. It will answer such questions, after being fed proper data, as: Should I sell this group of pigs as feeders or feed them out to market weight? Should I hold a lot of feeder cattle for another month or should I sell them now? Should I trade in my combine on a new one this year or wait until next year?”

“The computer can’t predict the weather—yet!—but it can predict the effects of weather. There already is a system that records the weather of all major weather stations every six hours and computes soil moisture as a major variable. This variable permits conclusions regarding the most likely time to prepare spring soil, to plant crops, and to fertilize—all as early as November of the previous year. As long range weather forecasting becomes more accurate, these forecasts fed into the computer will greatly enhance this kind of service.

“But a computer use that greatly intrigues me is the exciting experiments presently going on aimed at the use of remote-sensing procedures to identify crops, detect crop diseases and insects, indicate soil moisture conditions, and forecast yields.”

"Hold it!" Barney interrupted. "Haven't you jumped the track a bit? Remote sensing is one thing; a computer is another."

"Let me explain: The Purdue Laboratory for Agricultural Remote Sensing has been conducting experiments in the automatic classification of crops from airborne multispectral data. The data is collected by an airplane flying over the area of interest. Both the reflectance and emission characteristics of the earth beneath is continuously sampled in many spectral bands between 0.32 and 15 micron wavelengths. The data is recorded on analog tapes and later converted to digital form.

"In one experiment, for example, the mean and variance of wheat samples were determined. Then the computer was instructed to print a 'W' for each sample point whose response was sufficiently near this mean value. Comparing this printout with an aerial photograph of the land revealed a relatively high accuracy of classification for a single channel of data. A rectangular field of wheat with oats planted in the center came out as a rectangular pattern of W's with a rectangular blank space in the center. But increasing the number of data channels increased the accuracy still more, and it is possible, knowing the altitude of the aircraft, to determine the area covered by the classified crop. The U.S. Department of Agricultural Statistical Crop Reporting Service may soon be using such methods to determine crop acreage.

"On the other hand, a satellite may soon steal the show. The Earth Resources Technology Satellite is expected to be given the green light very soon that will result in a \$20-25 million contract from NASA for a polar orbiting spacecraft to monitor crop, forest, and water conditions around the world from outer space.

"Several firms are seeking the 'space farm agent' contract, including such giants as RCA, G-E, Westinghouse, TR Systems, Ball Brothers, McDonnell Douglas, Philco-Ford, and Boeing. While undoubtedly proposals will differ in details, the one by Westinghouse is probably typical.

"Westinghouse proposes a satellite with a 142-pound payload containing a color image dissector camera capable of obtaining a useful resolution of crops within a 100-foot plot from 100 miles in space. The image dissector was chosen not only because of its greatly improved resolution over a vidicon but also because of its speed. A picture of the earth from a satellite moving at 21,000 ft/sec must be taken in a millisecond if that 100-ft resolution is not to be smeared. The image dissector gives an immediate picture with almost instantaneous readout for relay back to ground, while a vidicon requires 30-40

milliseconds to get a picture on the tube face and even longer to read and erase. The image dissector is so sensitive it can image the earth even under moonlight conditions.

"Three special filters on the image dissector's face will focus on three photomultipliers. The three spectral colors will be 4000 angstroms, 5000 angstroms, and 6000 angstroms. With these three colors, it is claimed the 'color signature' of each crop can be read.

"The satellite will also carry an infrared detector in the 1-micron region. Since vigorous crops absorb the sun's heat while diseased plants reflect it, this detector will permit assessing the health of crops. The satellite will also be able to spot vast schools of fish in the ocean by photographing the characteristic fluorescence of the plankton the fish follow. Other services it may perform are to photograph water pollution and track it to its source and to spot forest fires.

"The satellite will take some 250 pictures of the earth on each orbit with each photo covering 100 square miles of the earth's surface. Such high density of data requires a very rapid fine-dot scanner for printing the data on film; so a laser scanner running at a 6-megahertz rate will be used for this purpose. Since manual examination of each frame is patently impossible, computer processing will be used to locate interesting areas. The particular photo can then be enlarged to get a close visual look at a 100-foot plot."

"Okay, okay! I've eaten my words," Barney interrupted. "You've convinced me there will be lots of sophisticated electronics in the farmer's future. And, if the exploding world population is to continue eating, electronics is coming to the farmer's aid none too soon."

Stretching lazily, he began to chant: "Old MacDonald had a farm, eeyi, eeyi, O

And on this farm he had a computer, eeyi, eeyi O!" ▲

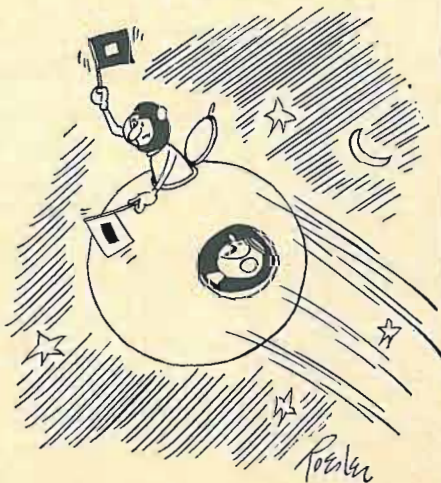

"But I always thought communications satellites operated differently."

Trygon's New EAL Series Laboratory Power Supply

■ This is Trygon's new EAL wide-range laboratory power supply—four models in the most commonly used laboratory voltage ranges. At \$99, it's a giant.

■ And it's a clean giant. Clean output, with ripple less than .5mv rms, plus rock-steady .01% regulation, .05% stability.

■ Clean, compact all-metal case, too, that doesn't waste an inch of bench space. The switchable volt/ammeter, concentric coarse and fine voltage controls, pilot light and output terminals (fully floating output) are all on the front panel.

Meet Trygon's Jolly Clean Giant



TRYGON ELECTRONICS, Inc.
111 Pleasant Ave., Roosevelt, L.I., N.Y. 11575*

I need the following EAL unit(s).

Qty.	Model	Rating
....	EAL 10-1	0-10 VDC @ 1.0 Amp
....	EAL 20-500	0-20-VDC @ 500 ma
....	EAL 32-300	0-32 VDC @ 300 ma
....	EAL 50-250	0-50 VDC @ 250 ma

Name _____ Title _____

Firm _____

Address _____

City _____ State _____ Zip _____

- Purchase Order Attached.
 Contact us for Purchase Order.
 Please send Trygon Power Supply Handbook.

*PRICES SLIGHTLY HIGHER IN EUROPE.

TRYGON GMBH, 8 MUNCHEN 60, HAIDELWEG 20, GERMANY.

CIRCLE NO. 194 ON READER SERVICE CARD

FREE!



BRAND NEW SPRING & SUMMER RADIO-TV ELECTRONICS CATALOG



YOUR BUYING GUIDE
FOR: • Stereo & Hi-Fi
Systems & Components
• Tape Recorders • Elec-
tronic Parts, Tubes, Tools
• Phonos & Records
• Ham Gear • Test In-
struments & Kits • Cam-
eras & Film • PA • Cit-
izens Band • Radio & TV
Sets • Musical Instru-
ments

MAIL TODAY TO:

BURSTEIN-APPLEBEE

Dept. EWP 1012 McGee, Kansas City, Mo. 64106

Name _____
Address _____
City _____
State _____ Zip Code _____

CIRCLE NO. 121 ON READER SERVICE CARD

Need high temperatures in tiny places?

The amazing Little Torch is so tiny it can throw a flame of 6300-F. through the eye of a needle. It solders, brazes, welds and heats with exacting precision in the smallest places; uses oxygen and acetylene, hydrogen, propane, natural gas or Mapp. It's available with five tips ranging in size from one large enough to weld 16 ga. steel to one small enough to weld .002" copper wire. For free brochure write to:



Dept. 433-8, 2633 S.E. 4th St., Minneapolis, Minnesota 55441
CIRCLE NO. 90 ON READER SERVICE CARD

result of video pips on the other 262 lines, during the alternate vertical field. Its position is determined by a voltage from the detector circuits, which sense the frequency of the 45.75-MHz i.f.

The detector circuits aren't as simple as those in other fine-tuning aids, either. Instead of sensing the peak, the system senses when the 45.75-MHz signal is at a particular point on the slope of the detector curve. The first peak detector uses the strength of the video signal to counteract effects of weak signals which might otherwise produce false indications from the slope detector.

The output of the slope detector is a steady video signal whose strength depends on correct tuning. The second peak detector rectifies that signal and produces a d.c. voltage that sets the position of the movable video pips on each alternate horizontal line of the raster. (A complete description of this circuit and its servicing adjustments can be found on page 68 of our December 1967 issue.)

Fine-Tuning Automatically

Besides these manual aids, there are automatic fine-tuning systems, which were described in some detail in the January 1968 issue (page 41). Their operation is two-fold: a 45.75-MHz sensing circuit very much like those used for manual fine-tuning indication; and a tuner whose tuning can be affected by a d.c. control voltage developed in the sensing circuit. Basically, an automatic fine-tuning circuit senses when the local oscillator drifts off frequency enough to reduce the 45.75-MHz signal sensed by the a.f.t. circuit, then produces a d.c. correction voltage which is applied to the tuner to pull the oscillator back on frequency.

Fig. 7 shows the system in simplified block form. Tubes have been used, although most recent models use transistors. You'll even find integrated circuits in the a.f.t. stages of a few models—notably *Clairtone*, *RCA*, and *Zenith*. Most models apply a.f.t. to both u.h.f. and v.h.f. tuners. A backward-biased capacitance diode completes the tuning circuit in the oscillator. The d.c. correction voltage from the a.f.t. discriminator shifts the capacitance in whatever direction is needed to bring the oscillator back to correct frequency so a precise 45.75-MHz video i.f. is produced.

The correct procedure for fine-tuning a color receiver

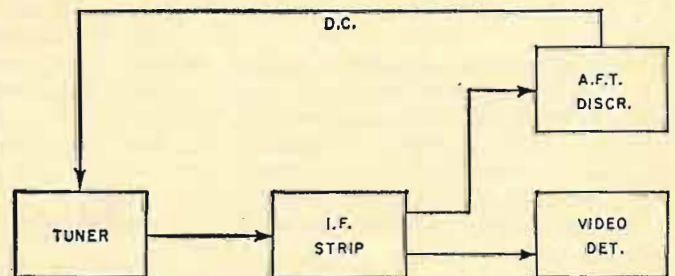
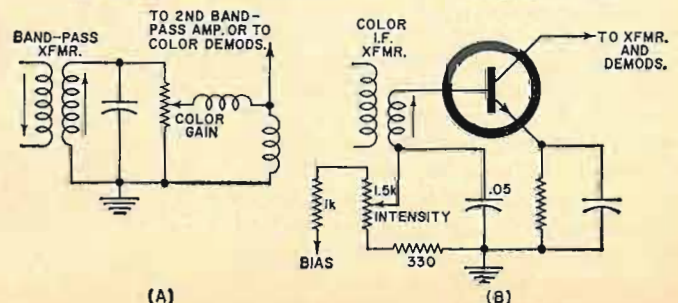

Fig. 7. Closed loop that forms automatic fine-tuning system.

Fig. 8. Typical color controls. (A) Most popular one acts like a color "volume control". (B) One that controls bias.



(A)

(B)

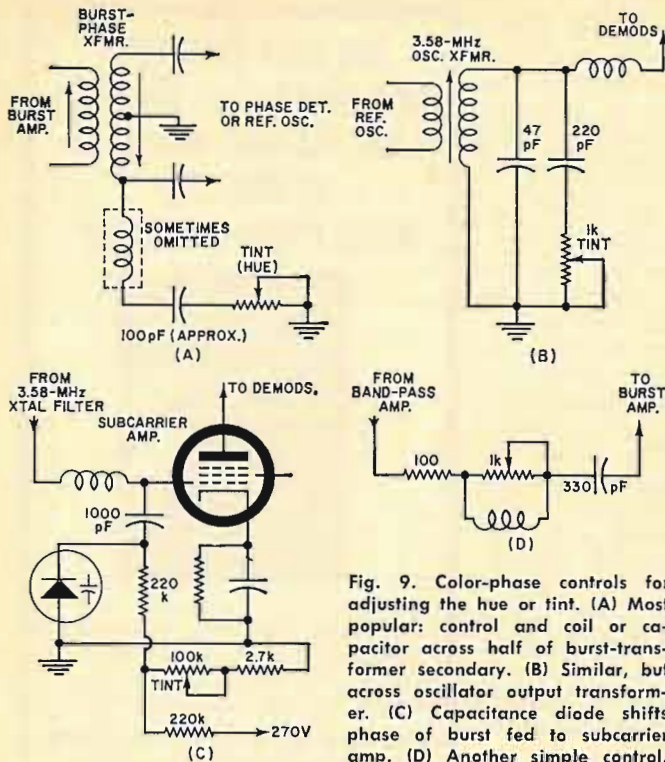

Fig. 9. Color-phase controls for adjusting the hue or tint. (A) Most popular: control and coil or capacitor across half of burst-transformer secondary. (B) Similar, but across oscillator output transformer. (C) Capacitance diode shifts phase of burst fed to subcarrier amp. (D) Another simple control.

that has a.f.t. is the same as for any other, except that the a.f.t. must be defeated during the fine-tuning process. In some tuners, the a.f.t. is automatically disabled when you push in the fine-tuning control to tune it; others have an a.f.t. defeat switch which must be set in the "a.f.t. defeat" or "a.f.t. off" position.

The knob is tuned just as described earlier, first for best sound with no picture and then for a good picture as near "best sound" as possible. After that, reactivate the a.f.t. and it will hold the tuner precisely on frequency. The fine tuning should be set individually for each active channel, then it seldom needs resetting thereafter. Don't disturb this setting unless there is reason to believe the tuner has, over a period of time, drifted beyond the influence of the a.f.t. circuit. (One *Motorola* model includes a fine-tuning indicator in addition to the a.f.t. circuit; a warning lamp glows if there is excess drift.)

Color and Hue Controls

Chroma controls haven't changed much over the past few years. Their place and function in the circuit have been much the same for some time. If you've seen many color-TV sets, you're already familiar with the popular arrangement in Fig. 8A. The control is merely a "volume control" following one band-pass amplifier (color i.f., *Motorola* calls it). In some models, another band-pass amplifier follows the control; in others, the demodulators. *Motorola*, which calls this control the Intensity control, places it in the cathode circuit of one color i.f. (band-pass) amplifier, a cathode-follower that drives the following stage. In the new *Motorola* transistor color receiver, the Intensity control is a potentiometer that sets the d.c. bias of one color i.f. amplifier (Fig. 8B). *Zenith*, in a tube model, also uses a bias-control pot for controlling chroma gain; they place it in the cathode circuit of one band-pass amplifier (which the *Zenith* schematic calls a *color amplifier*).

Phase controls, too, aren't much different from those in use several years ago, although there is a wider variety of circuit schemes. The basic purpose of the Hue or Tint control is, ultimately, to affect the phase of the reference (3.58-MHz) signal fed to the demodulators, which affects the angle of demodulation and thus the hue of the signals applied to the CRT guns. This can be done by altering the

Weller®

makes first class soldering the easiest part of any job



NEW
Weller
BATTERY OPERATED
Iron for field servicing

Now get controlled 700°F tip temperature from a battery! Lightweight TCP-12 iron features Weller's patented "Temperature Sensing" system, clips to any 12-volt battery or 12-14 volt AC/DC source. Also available for 24-28 volt operation (Model TCP-24). A must for mobile communications work.

Efficient MARKSMAN Irons for continuous-duty soldering



Ideal for the bench or caddy, Marksman irons outperform others of the same size and weight. Five models feature long-reach, stainless steel barrels and replaceable tips.

- 1¼-oz, 25-watt Model SP-23
- 2-oz, 40-watt Model SP-40
- 4-oz, 80-watt Model SP-80
- 10-oz, 120-watt Model SP-120
- 16-oz, 175-watt Model SP-175



Dual Heat Soldering Guns for dependable maintenance and repair

The most widely used gun in the electronics field. Available in three wattage sizes, each with Weller's exclusive trigger-controlled dual heat, pure copper tip, and spotlight.

- 100/140-watt Model 8200
- 145/210-watt Model D-440
- 240/325-watt Model D-550

25-watt Technician's Iron for intricate circuit work



Industrial rated pencil iron weighs only 1¼ ounces, yet delivers tip temperatures to 860°F. Cool, impact-resistant handle. All parts readily replaceable. Model W-PS with ½-inch tapered tip.

Complete Weller Line at your Electronic Parts Distributor

WELLER ELECTRIC CORPORATION, Easton, Pa.
 WORLD LEADER IN SOLDERING TOOLS
 CIRCLE NO. 89 ON READER SERVICE CARD

When you need quality power supplies, specify **Lambda**

Modular Power Supplies for OEM and Systems Use

LM Series



Up to 150 VDC; up to 150 Amps • 9 Package Sizes • Meet MIL Specs

Test and Laboratory Power Supplies for Rack or Bench Mounting.

LP Series

0—10, 20, 40, 60, 120,
250 VDC; up to 2 Amps
Completely Portable



LPD Series Dual Output Power Supplies

0—±20, ±40,
±60, ±120,
±250VDC; up to 1.7 Amps
Ideal for operational amplifier applications •
Most amps per dollar.



LH Series



0—10, 20, 40, 60, 120 VDC; up to 4 Amps
in ¼ rack models; up to 9 Amps in ½ rack
models. Meet MIL Specs.

LK Series



0—20, 36, 60 VDC; up to 13.5 Amps in ½
rack models; up to 66 Amps in full rack
models. Meet MIL Specs.

All Lambda DC Regulated Power Supplies are convection cooled, use all silicon and are guaranteed for 5 years. Lambda is the only power supply manufacturer who provides a 5-year guarantee on materials and labor.

SEND FOR COMPLETE CATALOG

A  SUBSIDIARY

LAMBDA

Terminal Drive, Plainview, L. I., New York 11803
516-681-8300

CIRCLE NO. 197 ON READER SERVICE CARD
66

phase of the color-sync (burst) signal before it reaches the reference oscillator, or by altering the phase of the reference signal after it is generated but before it reaches the demodulators. Both methods are used, but the former is the more popular.

The basic circuit arrangement in Fig. 9A is common to *Clairtone*, *Hoffman*, *Magnavox*, *Motorola*, *Packard Bell*, *Philco*, *Setchell Carlson*, and *Zenith*. In some of them, only the capacitor is used, without the extra inductance; in *Zenith*, only a potentiometer is used. Varying the potentiometer setting introduces more or less of the effect of the capacitor (or coil-capacitor) across one winding of the burst transformer, shifting the phase of the burst signal that is passed on to the phase detector. This, in turn, controls the reference oscillator phase. In the *Zenith*, the pot alone merely unbalances the winding and thus alters phase.

A similar arrangement (Fig. 9B), except that it is in the reference-oscillator output transformer circuit, is used in *Admiral* and many *RCA* models. The pot and capacitor are across the winding, but interact with the inductance that follows.

One recent *G-E* model uses something entirely different, although its purpose and result are the same. Fig. 9C shows the arrangement; a biasing potentiometer that varies bias on a varicap diode in the special subcarrier amplifier circuit that *G-E* uses instead of the more common controlled oscillator. The stage amplifies the incoming 3.58-MHz burst, which arrives through a 3.58-MHz quartz-crystal filter, then feeds its phase-locked output to the demodulators. The variable-capacitance diode controls the phase of that output, depending on the bias set for it by the potentiometer.

Recent *Arvin* sets are different, too. Phase is controlled in them by the very simple device shown in Fig. 9D—a coil-capacitor combination, in series, preceding the burst amplifier. A potentiometer across the coil is the means for varying the phase shift introduced by the network. Simple, but effective.

There are minor variations of these Color and Hue controls from model to model, but most Hue controls resemble one of those we have already discussed.

Striving for Perfection

To further simplify color-TV tuning for viewers, manufacturers have attempted to make the control of color and phase more and more "automatic". To some small extent, they have succeeded. Many chassis have what are called automatic color control (a.c.c.) and automatic phase control (a.p.c.) or automatic frequency and phase control (a.f.p.c.). However, they are automatic

THE ONLY COMPLETE AND UP-TO-DATE GUIDE TO THE EXCITING WORLD OF SPECIALIZED RADIO COMMUNICATIONS!

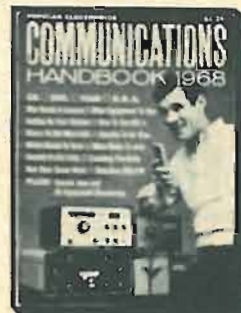

Whether you're a ham, short wave listener, CB'er or business radio operator . . . a newcomer to the fascinating world of radio communications or an oldtimer who cut his teeth on crystal sets . . .

You need a copy of the new 1968 COMMUNICATIONS HANDBOOK!

It's packed with over 150 pages of "how to do it—how to do it better" features written by the experts in each category. From choosing your field . . . to learn in the code . . . to getting your license . . . to setting up your own station . . . to winning awards!

And note this:

You also get valuable directories of the latest ham and CB equipment for both novice and technician class — PLUS hundreds of photos, charts, lists and tables . . . everything you need to get the most enjoyment from your hours on the air!

THE 1968 COMMUNICATIONS HANDBOOK IS READY RIGHT NOW. Use the coupon below to order your copy TODAY! It's just \$1.25.

GET THE HANDSOME LEATHERFLEX-BOUND EDITION for just \$3 POSTPAID! The 1968 COMMUNICATIONS HANDBOOK is also available in a splendid deluxe edition. Rugged Leatherflex cover provides lasting protection yet is softly textured and gold-embossed for the look of elegance. A collector's item—a superb addition to your permanent reference library. And it's yours, for just \$3 postpaid, when you check the appropriate box on the order form.

ZIFF-DAVIS SERVICE DIVISION • DEPT. CH
595 Broadway • New York, N.Y. 10012

OK! Send me the new 1968 COMMUNICATIONS HANDBOOK.

\$1.25 enclosed, plus 15c for shipping and handling. Send me the regular edition. (\$1.75 for orders outside the U.S.A.)

\$3.00 enclosed. Send me the Deluxe Leatherflex-bound edition, postpaid. (\$3.75 for orders outside the U.S.A.) Allow three additional weeks for delivery.

print name _____
address _____ EW-48
city _____
state _____ zip code _____

PAYMENT MUST BE ENCLOSED WITH ORDER

only in the same sense that automatic gain control (a.g.c.) is automatic, not in the absolute sense that automatic fine tuning (a.f.t.) is automatically accomplished.

Automatic color control is merely an "a.g.c." for the band-pass amplifiers. If the color signal weakens, the gain is raised slightly; if it becomes so strong that it makes the colors on the screen too harsh, the gain is reduced by the a.c.c. circuit. The result is a fairly stable color saturation level, that is, the system can maintain the color at whatever level is set by the viewer with the Color control.

The terms a.p.c. or a.f.p.c. are merely names for the circuit that applies color sync to the color reference oscillator. True, its job is to keep the oscillator in exact phase, but that phase still depends on the incoming color burst. The "automatic" action is not sufficient to overcome the phase differences that so often occur from camera to camera, from program to program, and from station to station. For that reason, viewers must still get up and alter the setting of the control several times during an evening of color viewing. Thus far, no manufacturer has perfected an a.p.c. circuit with sufficient range or adequate sensitivity to pull the oscillator into phase automatically in such cases—advertising claims notwithstanding.

Thus, perfection is still unattained. Step by step, though, color-set manufacturers are licking each problem. Only three years ago, one of the toughest problems of the color television installer was to teach the viewer how to make sure the Fine Tuning was correct for watching color; now there's a.f.t. Rest assured that it won't be long until every single control on a color set can be preset and will then operate automatically. Even the presetting will be handled by aids of the type used now only for the most troublesome adjustments. ▲

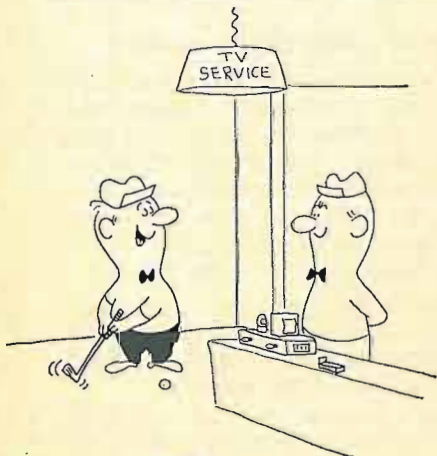

L. Lyons

"Just practicing in case the TV quits at the golf club!"

Now...the most enjoyable, most rewarding electronic kit project of your life



a Schober Electronic Organ!

The Schober Organ Corporation
43 West 61st Street, New York, N. Y. 10023

HAD YOUR FILL of amplifier kits, receiver kits, meter kits, all the conventional kits? Then go to work on the biggest, most fascinating kit of them all—and end up with a finer musical instrument than you could buy for twice the price. The Schober Theatre Organ at left, for example, plus Schober's self-teaching music courses, lets you *participate* in music, not just listen to it. This is one electronic project the wife and kids will encourage—because it's for them, too! It contains the best components available—thousands of them—plus the kind of unmistakable, step-by-step instructions you've dreamed of and Schober is famous for.

The Theatre Organ (*left*) costs just \$1550 if you use your own amplifier and speaker system, and you can pay as you build to spread out the cost. There are three other Schober Organ models, too, starting at \$645. Each one includes every bit and piece you need, including a magnificent walnut console—unless you want to build your own woodwork and save even more. And each model has the kind of pipelike tonal variety you don't often find in electronic organs. The free Schober color catalog has lots of pictures and data; and for 25¢ we'll send you 72 pages of schematics and tech specs so you can see just what you're buying.

FREE INFORMATION AND DEMONSTRATION RECORDING
Send today for your free copy of Schober's 16-page, full color booklet, plus 7" free recording.

The Schober Organ Corp., Dept. RN-55
43 West 61st Street, New York, N. Y. 10023

Please send me Schober Organ Catalog and free 7-inch "sample" record.

Enclosed please find \$1.00 for 12-inch L.P. record of Schober Organ music.

Enclosed is 25¢ for schematics and tech specs.

NAME

ADDRESS

CITY..... STATE..... ZIP NO.....

CIRCLE NO. 94 ON READER SERVICE CARD

Enjoy the "music-only" programs now available on the FM broadcast band from coast to coast.

- NO COMMERCIALS •
- NO INTERRUPTIONS •



It's easy! Just plug Music Associated's Sub Carrier Detector into multiplex jack of your FM tuner or easily wire into discriminator. Tune through your FM dial and hear programs of continuous, commercial-free music you are now missing. The Detector, self-powered and with electronic mute for quieting between selections, permits reception of popular background music programs no longer sent by wire but transmitted as hidden programs on the FM broadcast band from coast to coast. Use with any FM tuner. Size 5½" x 9". Shipping weight approx. 7 lbs.

KIT \$49.50
(with pre-tuned coils, no alignment necessary)

WIRED \$75.00

COVER \$4.95 EXTRA

Current List of FM Broadcast Stations with SCA authorization \$1.00

MUSIC ASSOCIATED

65 Glenwood Road, Upper Montclair, N.J. 07043
Phone: (201)-744-3387

CIRCLE NO. 102 ON READER SERVICE CARD

Olson



FREE

Fill in coupon for a **FREE** One Year Subscription to **OLSON ELECTRONICS' Fantastic Value Packed Catalog—Unheard of LOW, LOW PRICES on Brand Name Speakers, Changers, Tubes, Tools, Stereo Amps, Tuners, CB, Hi-Fi's, and thousands of other Electronic Values. Credit plan available.**

NAME

ADDRESS

CITY..... STATE.....

GIVE ZIP CODE

If you have a friend interested in electronics send his name and address for a **FREE** subscription also.

OLSON ELECTRONICS, INC.

841 S. Forge Street Akron, Ohio 44308

CIRCLE NO. 101 ON READER SERVICE CARD

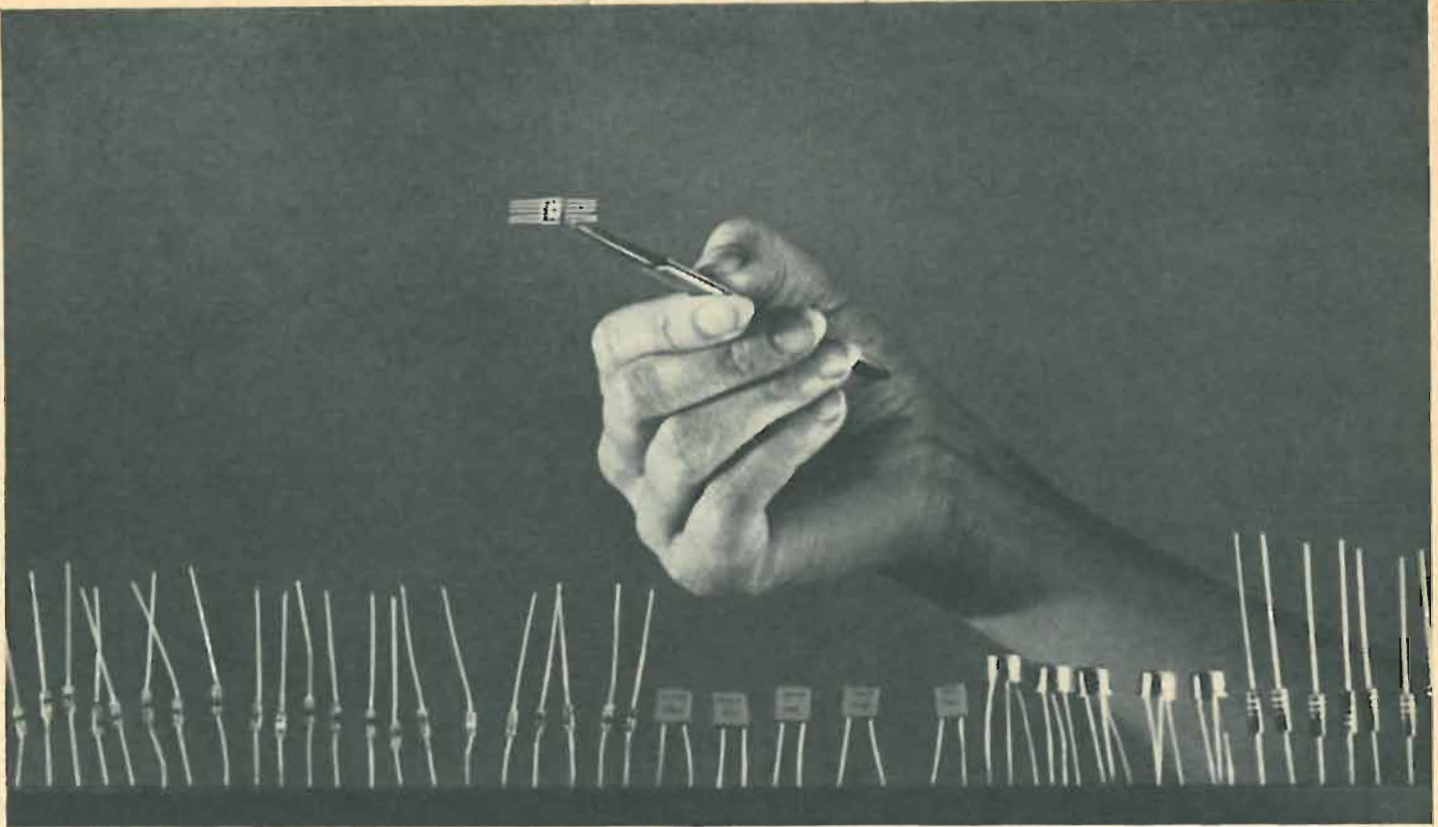

50 functions in a single chip. The functions of 50 separate transistors, diodes, resistors and capacitors can now be formed by the tiny dot in the center of the integrated circuit held by the tweezers.

The "Chip"

...will it make or break your job future?

THE DEVELOPMENT OF INTEGRATED CIRCUITRY is the dawn of a new age of electronic miracles. It means that many of today's job skills soon will be no longer needed. At the same time it opens the door to thousands of exciting new job opportunities for technicians solidly grounded in electronics fundamentals. Read here what you need to know to cash in on the gigantic coming boom, and how you can learn it right at home.

TINY ELECTRONIC "CHIPS," each no bigger than the head of a pin, are bringing about a fantastic new Industrial Revolution. The time is near at hand when "chips" may save your life, balance your checkbook, and land a man on the moon.

Chips may also put you out of a job...or into a better one.

"One thing is certain," said *The New York Times* recently. Chips "will unalterably change our lives and the lives of our children probably far beyond recognition."

A single chip or miniature integrated circuit can

perform the function of 20 transistors, 18 resistors, and 2 capacitors. Yet it is so small that a thimbleful can hold enough circuitry for a dozen computers or a thousand radios.

Miniature Miracles of Today and Tomorrow

Already, as a result, a two-way radio can now be fitted inside a signet ring. A complete hearing aid can be worn entirely inside the ear. There is a new desk-top computer, no bigger than a typewriter yet capable of 166,000 operations per second. And it is almost possible to put the entire circuitry of a color television set inside a man's wrist-watch case.

And this is only the beginning!

Soon kitchen computers may keep the housewife's refrigerator stocked, her menus planned, and her calories counted. Her vacuum cleaner may creep out at night and vacuum the floor all by itself.

Money may become obsolete. Instead you will simply carry an electronic charge account card. Your employer will credit your account after each week's work and merchants will charge each of your purchases against it.

When your telephone rings and nobody's home, your call will automatically be switched to the phone where you can be reached.

Doctors will be able to examine you internally by watching a TV screen while a pill-size camera passes through your digestive tract.

New Opportunities for Trained Men

What does all this mean to someone working in electronics who never went beyond high school? It means the opportunity of a lifetime—if you take advantage of it.

It's true that the "chip" may make a lot of manual skills no longer necessary.

But at the same time the booming sales of articles and equipment using integrated circuitry has created a tremendous demand for trained electronics personnel to help design, manufacture, test, operate, and service all these marvels.

There simply aren't enough college-trained engineers to go around. So men with a high school education who have mastered the fundamentals of electronics theory are being begged to accept really interesting, high-pay jobs as engineering aides, junior engineers, and field engineers.

How To Get The Training You Need

You can get the up-to-date training in electronics fundamentals that you need through a carefully chosen home study course. In fact, some authorities feel that a home study course is the best way. "By its very nature," stated one electronics publication recently, "home study develops your ability to analyze and extract information as well as to strengthen your sense of responsibility and initiative." These are qualities every employer is always looking for.

If you do decide to advance your career through spare-time study at home, it makes sense to pick an electronics school that specializes in the home study method. Electronics is complicated enough without trying to learn it from texts and lessons that were designed for the classroom instead of correspondence training.

The Cleveland Institute of Electronics has everything you're looking for. We teach only electronics—no other subjects. And our courses are designed especially for home study. We have spent over 30 years perfecting techniques that make learning electronics at home easy, even for those who previously had trouble studying.

Your instructor gives your assignments his undivided personal attention—it's like being the only student in his "class." He not only grades your work, he analyzes it. And he mails back his corrections and comments the same day he gets your lessons, so you read his notations while everything is still fresh in your mind.

Always Up-To-Date

Because of rapid developments in electronics, CIE courses are constantly being revised. Students re-

Tiny TV camera
for space and military use is one of the miracles of integrated circuitry. This one weighs 27 ounces, uses a one-inch vidicon camera tube, and requires only four watts of power.



ceive the most recent revised material as they progress through their course. This year, for example, CIE students are receiving exclusive up-to-the-minute lessons in Microminiaturization, Logical Troubleshooting, Laser Theory and Application, Single Sideband Techniques, Pulse Theory and Application, and Boolean Algebra. For this reason CIE courses are invaluable not only to newcomers in Electronics but also for "old timers" who need a refresher course in current developments.

Praised by Students Who've Compared

Students who have taken other courses often comment on how much more they learn from CIE. Mark E. Newland of Santa Maria, California, recently wrote: "Of 11 different correspondence courses I've taken, CIE's was the best prepared, most interesting, and easiest to understand. I passed my 1st Class FCC exam after completing my course, and have increased my earnings \$120 a month."

Get FCC License or Money Back

No matter what kind of job you want in electronics, you ought to have your Government FCC License. It's accepted everywhere as proof of your education in electronics. And no wonder—the Government licensing exam is tough. So tough, in fact, that without CIE training, two out of every three men who take the exam fail.

But better than 9 out of every 10 CIE-trained men who take the exam pass it.

This has made it possible to back our FCC License courses with this famous Warranty: you *must* pass your FCC exam upon completion of the course or your tuition is refunded in full.

Mail Card For Two Free Books

Want to know more? The postpaid reply card bound in here will bring you a free copy of our school catalog describing today's opportunities in electronics, our teaching methods, and our courses, together with our special booklet on how to get a commercial FCC License. If card has been removed, just send us your name and address.

ENROLL UNDER NEW G.I. BILL

All CIE courses are available under the new G.I. Bill. If you served on active duty since January 31, 1955, or are in service now, check box on reply card for G.I. Bill information.

CIE

Cleveland Institute of Electronics

1776 E. 17th St., Dept. EW-44, Cleveland, Ohio 44114

Accredited Member National Home Study Council
A Leader in Electronics Training... Since 1934



Delta Launches the COMPUTACH®*



The
Great
One!

*An exclusive computer-tachometer for precise RPM measurement in easy-to-build Kit form!



ONLY
\$29.95
ppd.

Delta, pioneers in CD ignition who produced the fabulous MARK TEN®, now offer a precise computer-tachometer which obsolesces any type tachometer on the market today! You achieve unbelievable accuracy in RPM readings due to the advanced, solid-state electronic matched components used in the computer, coupled with the finest precision meter in the world. In kit only for all 12V, 8 cyl. cars.

Check these Deltafeatures:

- ▲ 0-8000 RPM range
- ▲ Perfect linearity — zero parallax
- ▲ Adjustable set pointer
- ▲ Wide angle needle sweep
- ▲ Translucent illuminated dial
- ▲ Chrome plated die-cast housing
- ▲ All-angle ball & socket mounting
- ▲ Use it with any ignition system
- ▲ Meter: 3 3/8" dia. X 3 3/8" deep
- ▲ Kit complete, no extras to buy

Orders shipped promptly.
Satisfaction guaranteed.
Send check today!



DELTA PRODUCTS, INC. DP 0-2

P.O. Box 1147 EW / Grand Junction, Colo. 81501
Enclosed is \$ _____ Ship ppd. Ship C.O.D.
Please send:
 COMPUTACH® Kits @ \$29.95 ppd
(12 VOLT 8 CYLINDER VEHICLES ONLY)

Name _____
Address _____
City/State _____ Zip _____

CIRCLE NO. 117 ON READER SERVICE CARD

TEST EQUIPMENT PRODUCT REPORT

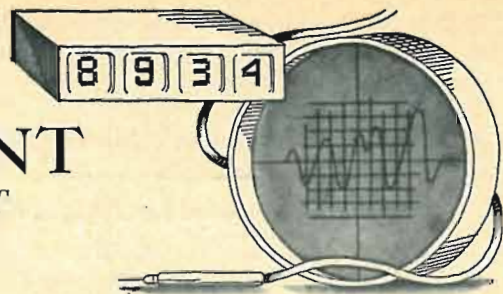

RCA Model WT-501A Transistor Tester

For copy of manufacturer's brochure, circle No. 29 on Reader Service Card.



THE new WT-501A recently introduced by RCA is a portable, battery-operated transistor tester, designed for both in-circuit and out-of-circuit applications. The instrument measures d.c. *beta* from 1 to 1000, collector-to-base leakage (I_{CBO}) as low as $2 \mu A$, and collector-to-emitter leakage (I_{CEO}) ranging from $20 \mu A$ to 1 A. Special low-impedance circuitry assures reliable measurement of in-circuit transistor current gain.

The collector current in the WT-501A is continuously adjustable from $20 \mu A$ to 1 A, permitting both low- and high-power transistors to be tested at appropriate collector current. Some low-power, small-signal transistors will have extremely low *beta* or no *beta* at all if tested with collector current above several mA. A normal *beta* reading would be obtained only if these transistors were tested at their rated current level. Similarly, a power transistor tested with a collector current of 1 mA may have little or no gain, yet would have normal *beta* if tested at 100 mA or 1 A.

Recommended test-current levels are 10 mA for most signal-type transistors (r.f., i.f.), 100 mA for intermediate-power transistors, and 1 A for high-power and audio transistors. If available, the collector current specified

by the transistor manufacturer can be used.

A d.c. forward current transfer curve (*beta* curve) can be plotted using the WT-501A. This is one of the most useful references in evaluating transistor performance since it indicates at a glance the gain of the transistor at various levels of collector current.

The relative front-to-back ratio of diodes can also be checked with the tester, either in-circuit or out-of-circuit. Again, the advantage of this tester is that it can check diodes as well as transistors at a suitable current level.

Two sockets are provided on the panel, one for *n-p-n* transistors and the other for *p-n-p* transistors. This permits convenient transistor matching for complementary symmetry applications. Three color-coded test leads are provided for in-circuit connections, and for out-of-circuit tests of transistors that do not fit the panel sockets.

A simplified diagram of the *beta* test circuit is shown here. Resistors R_B and R_C serve both to establish the collector current and to shunt the meter to the required sensitivity. When the range switch is set to the "Cal" function, the meter is in the collector circuit. Collector current is determined by the value of the collector resistor for the particular range, and by the setting of the "Cal" control. In the "Beta" function, the meter is switched to the base circuit. The d.c. *beta* is defined as the ratio of the d.c. collector current to the d.c. base current. Since the collector current is established at a known value by the "Cal" adjustment, the base current meter reading can be inter-

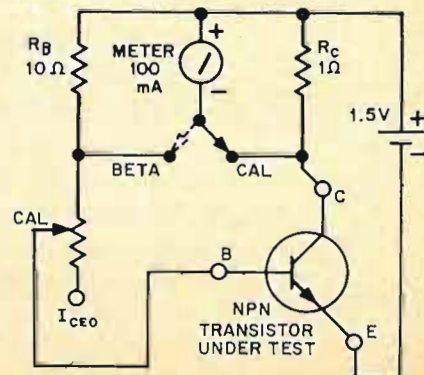

preted in terms of d.c. *beta* for the transistor.

The test circuit for measuring in-circuit current gain is similar to that used for out-of-circuit *beta*. A zero-adjust control is included to apply a voltage of reverse polarity to the collector metering circuit, compensating for the collector-to-emitter leakage through the components in the circuit under test.

A 100-microampere meter movement is used in the measuring circuits for the various test functions. Precision resistors are used to insure accurate test results. An "N-p-n P-n-p" switch provides the proper bias polarity of the transistor. Two dual potentiometers

provide coarse and fine adjustment of collector current ("Cal") and in-circuit zero.

The instrument has two internal 1.5-volt "D"-size batteries, one for use in the *n-p-n* test and the other in the *p-n-p* test.

The many features of the tester make the instrument valuable not only for servicing, but for educational, industrial, and laboratory applications as well.

The WT-501A is completely portable, weighing only 2¾ pounds. The instrument is supplied complete with an instruction manual and an RCA Transistor Manual. Optional user price is \$66.75. ▲

Honeywell Model 333 "Digitest" Digital Voltmeter

For copy of manufacturer's brochure, circle No. 30 on Reader Service Card.



THE Model 333 "Digitest" digital multimeter has been introduced by Honeywell for the technician who likes the versatility of a v.o.m., but who still requires the accuracy and convenience of a digital voltmeter. The meter can be operated from either built-in rechargeable nickel-cadmium batteries or the a.c. power line. A built-in charging circuit is provided. Automatic overrange indicator, decimal point placement, and polarity indication are included.

The "Digitest" is a 3-digit multimeter which can measure d.c. voltages from 100 μ V to 1000 volts, d.c. currents from 0.1 μ A to 1.0 ampere, a.c. voltages from 300 μ V to 300 volts, a.c. currents from 0.3 μ A to 300 mA, and resistance from 0.1 ohm to 1 megohm.

The unknown voltage to be measured is fed to an integrating amplifier which, in turn, feeds an analog-to-digital (A/D) converter. The A/D converter is made up of two monostables which produce pulses with widths directly proportional to the input voltage. Monostable #2 receives its input from the output of the integrating amplifier with respect to +14 volts reference.

The input to monostable #1 is common with respect to the +14 volts reference. The output pulses of these two monostables are fed to a logic circuit which, in turn, produces a pulse with a width equal to the difference in widths of the two input pulses. The pulse from this logic circuit, which is now proportional in width to the unknown input voltage, in turn gates the output of a 390-kHz oscillator. This enables the pulses from this reference oscillator to be counted and displayed on the cold-cathode gas tubes as a digital value equal to the unknown input voltage.

The advantage of referencing both monostables to the +14 V is that a slight variation in the reference voltage will have the same effect on both monostables and, therefore, will not affect the accuracy of the measurement.

Although this instrument features the ranges and functions normally associated with a v.o.m., v.t.v.m., or t.v.m., it provides accuracies of $\pm 0.5\%$ of reading +1 digit when measuring d.c. voltages. This accuracy is four to five times better than the conventional pointer-type meter.

When working from the internal bat-

The TRUE electronic solution to a major problem of engine operation!

DELTA'S FABULOUS MARK TEN®



Only \$44.95 ppd.
In easy-to-build Deltakit®
Only \$29.95 ppd.

CAPACITIVE DISCHARGE IGNITION SYSTEM

You've read about The Mark Ten in *Mechanix Illustrated*, *Popular Mechanics*, *Electronics* and other publications!

Now discover for yourself the dramatic improvement in performance of your car, camper, jeep, truck, boat—any vehicle! Delta's remarkable electronic achievement saves on gas, promotes better acceleration, gives your car that zip you've always wanted. Find out why even Detroit has finally come around. In four years of proven reliability, Delta's Mark Ten has set new records of ignition benefits. No re-wiring! Works on literally any type of gasoline engine.

Why settle for less when you can buy the original DELTA Mark Ten, never excelled and so unique that a U.S. Patent has been granted.

READY FOR THESE BENEFITS?

- ▲ Dramatic Increase in Performance and in Fast Acceleration
- ▲ Promotes more Complete Combustion
- ▲ Points and Plugs last 3 to 10 Times Longer
- ▲ Up to 20% Mileage Increase (saves gas)

LITERATURE SENT BY RETURN MAIL
BETTER YET—ORDER TODAY!



DELTA PRODUCTS, INC. DP 7-17

P.O. Box 1147 EW • Grand Junction, Colo. 81501

Enclosed is \$_____ Ship ppd. Ship C.O.D.

Please send:

- Mark Tens (Deltakit®) @ \$29.95
- (12 VOLT POSITIVE OR NEGATIVE GROUND ONLY)
- Mark Tens (Assembled) @ \$44.95
- 6 Volt: Negative Ground only.
- 12 Volt: Specify Positive Ground Negative Ground

Car Year _____ Make _____

Name _____

Address _____

City/State _____ Zip _____

CIRCLE NO. 116 ON READER SERVICE CARD

“
A tuner for the connoisseur...
thanks to SCOTTKIT® packaging
and exceptionally clear instructions
it can be put together
in about eight hours time...
pulled in
more stations
more clearly,

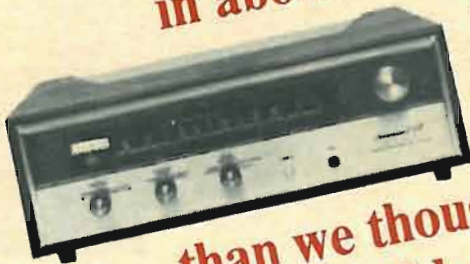

than we thought
could be logged
in our fringe area. ”
HIGH FIDELITY
MAGAZINE

See your
Scott dealer
and review the
new LT-112B-1 for yourself.
Only \$199.95. Matching
120-Watt LK-60B amplifier
kit, only \$199.95.

SCOTT

© 1968, H.H. Scott, Inc.

H.H. Scott, Inc., Maynard, Mass. 01754 Dept. 160-04

CIRCLE NO. 93 ON READER SERVICE CARD

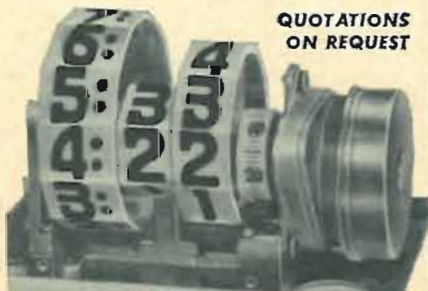

QUOTATIONS
ON REQUEST

12 HOUR
5/8 Digits
TYMETER
DIGITAL READ OUT
24 HOUR
5/16 Digits

CLOCK MOVEMENTS

DIGITS RESETTABLE INDIVIDUALLY

Available in 50, 60 cy., all voltages, AC. UL approved motor, cord. One Year Guarantee.

#130...12-HOUR #131...24-HOUR



TYMETER
CLOCK
MOVEMENT
as Used by
MOTOROLA

Complete Line: Delay, Interval
and Cycle Timers, Digital Computers
CATALOG ON REQUEST

PENNWOOD NUMECHRON CO.
TYMETER ELECTRONICS

7249 FRANKSTOWN AVE., PITTSBURGH, PA. 15208

CIRCLE NO. 193 ON READER SERVICE CARD

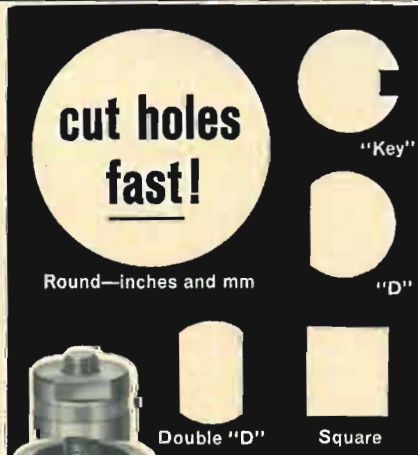

cut holes
fast!

Round—Inches and mm

“Key”

“D”

Double “D”

Square

with
**Greenlee
punches**

Here's the simple speedy way to cut smooth, accurate holes in metal, hard rubber, plastics, epoxy, etc.

Save hours of hard work... punch clean, true holes in seconds for sockets, controls, meters, and other components. Easy to operate. Simply insert punch in a small drilled hole and turn with a wrench. For use in up to 16-gauge metal. Available at leading radio and electronic parts dealers.

GREENLEE TOOL CO
DIVISION OF GREENLEE BROS. & CO.

1866 Columbia Avenue, Rockford, Ill. 61101
CIRCLE NO. 111 ON READER SERVICE CARD

teries, the operator can easily check their charge by means of a convenient “Battery” output located on the side of the meter. Thus the meter is able to read its own battery voltage and indicate to the operator if the batteries are sufficiently charged for accurate measurements. The calibration of the meter can also be easily checked against an accurate 10 V d.c. $\pm 0.1\%$ calibration voltage source made available at the “Ref” jack on the side of the instrument. Hence, the operator is able to calibrate the meter in a matter of seconds without the need for external calibration equipment.

Because of its versatility, operational simplicity, and portability, the “Digi-test” is an excellent laboratory or shop instrument for the bench or field technician. The automatic features, accuracy, and convenient digital display make it suitable for use as a production test tool or a readout device for such laboratory equipment as pH meters. Price of the Honeywell “Digi-test” is \$525. ▲

Eico Model 235 V.T.V.M.

For copy of manufacturer's brochure, circle No. 31 on Reader Service Card.



ALTHOUGH most of the new high-impedance volt-ohmmeters we have seen recently have been solid-state devices, the new Eico Model 235 v.t.v.m. uses tubes. There is still a lot to be said for the extremely simple, highly reliable 12AU7, 6AL5 v.t.v.m. circuit. To a good many technicians, an instrument of this type is the real “workhorse” of their service bench. And it is not at all uncommon to find such a meter left on all the time during a troubleshooting day; after all, the Model 235 just draws about 5 watts from the power line and long use merely improves its stability.

This new v.t.v.m. has a very useful 0.5-volt d.c. range for working on solid-

state equipment. Using the lowest division permits one to read voltage values as low as 10 mV on the 6-in meter face. Another innovation is the use of a floating ground. By isolating the signal ground from the instrument chassis, measurements can be made with both sides of the circuit far above ground potential. The new dual-function probe is really a pleasure to use too.

The new meter has eight d.c. voltage ranges, seven a.c. voltage ranges (scale markings are provided for both r.m.s. and peak-to-peak values), and seven resistance ranges. Accuracy is within 3 percent of full-scale while input impedance is 11 megohms on d.c. and 0.83 megohm or more on a.c. Frequency response on a.c. is said to be within 1 dB from 30 Hz out to 3 MHz.

As a kit, the meter is quite simple to construct. The entire circuit is contained on a printed-circuit board that mounts onto the meter-movement terminals. Once the two ceramic-insulation selector switches, two pots, and PC board are interconnected, the unit is ready to go. As a tribute to the clarity of the assembly manual, the writer's 14-year-old son was able to wire and calibrate the meter with absolutely no trouble.

The Model 235 sells for \$49.95 in kit form, or for \$69.95 factory-wired. ▲

EVERYMAN'S ANTENNA

ACCORDING to Peter Sielman of the *Airborne Instrument Laboratory*, a division of *Culter-Hammer Inc.*, communications satellites can provide an effective form of foreign aid. "If the United States were to launch two or more orbiting satellites and were to provide low cost transmitting equipment," he said, "underdeveloped countries could broadcast educational television programs to every schoolhouse within their boundaries."

The problem is that signals transmitted by communications satellites are in the 4- to 6-gigahertz band, and at this frequency an adequate receiving antenna is expensive and complex. However, if satellites were designed to transmit at 800 megahertz, a low-cost, easily installed home-made antenna could be used.

An end-fire antenna is most suitable since it can be designed to be completely collapsible. An array of four elements, each about 15 feet long, can be used. Each of the four elements in the array would have a gain of about 19 decibels, and the antenna would be circularly polarized.

A four "cigar antenna" array was developed and tested at *AIL*. It was made of 3/8-inch-diameter steel cable with a number of plastic discs (one side coated with metal) running the length of the element. The 0.3-wavelength diameter discs were spaced a 1/4 inch along the wire.

In laboratory tests the antenna performed well. Sielman estimates that this antenna can be made in quantity in underdeveloped countries for less than \$50. ▲

Reward

for the recovery of each of these shunt regulator tubes

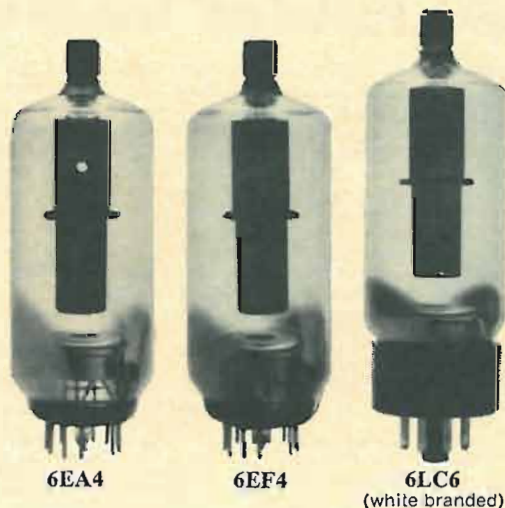

In early 1967, General Electric started a modification program to eliminate the possibility of soft downward x-radiation emission from some of its large screen color television receivers. This modification program, which involved replacement of the obsolete regulator tubes pictured above, is now complete except for a very few receivers which have not yet been located.

A second program is under way to encourage service technicians to replace the obsolete tubes in other models where they are present, even though the possibility of downward emission does not exist in these models. This program, which offers a \$5 reward plus a new replacement tube, can add to your earnings. To participate, you should be on the lookout for these three tube types whenever you service any large screen General Electric color receivers. Return the recovered tubes with the customer's name and address to any General Electric television distributor, or mail to:

General Electric Product Service Section
Northern Concourse Building
N. Syracuse, New York 13212

To promptly receive your free tubes and the reward, be sure to include your name and address.

A third program to recall all of these obsolete tubes from the replacement tube market is nearing completion. Should you still have unused tubes bearing these numbers in your shop or truck, send them to:

General Electric Company
P.O. Box 1008
Owensboro, Ky. 42301

You will receive a check in the amount of 50% of the list price plus transportation expense for each tube returned.

GENERAL ELECTRIC

CIRCLE NO. 81 ON READER SERVICE CARD

Important New SAMS BOOKS

BETTER
THAN EVER

NEW Third Edition of the famous Photofact® Television Course



by *The Howard W. Sams Engineering Staff*. This bestseller has been extensively revised and updated to provide a complete grasp of black-and-white television theory and circuitry. It is a comprehensive self-study course, written so anyone with a minimum background in electronics can understand all phases of tv. Now includes transistor circuit coverage. Step-by-step, the text, supported by numerous schematics, describes all basic circuits. Color is used in the illustrations for emphasis and clarity. This course not only explains tv principles and operation, from transmitter to receiver, but also provides training in service procedures. Questions are included at the end of each chapter, with answers at the back of the book. Also includes a glossary. 192 pages; 8½ x 11".
Order 20595, only.....\$495

General Class Amateur License Handbook

by *Howard S. Pyle, W7OE*. New second edition, completely revised and updated. Tells you how to get your Technician, Conditional, or General Class license (you don't have to begin as a Novice, but can go directly to a higher-class license). Provides a basic understanding of electronics theory, requirements for licenses, proved methods for learning the code; discusses transmitter circuits, FCC regulations, general operating practices. Includes latest changes introduced by the new incentive-licensing regulations. Gives typical questions for the FCC test and their answers. 144 pages; 5½ x 8½".
Order 20639, only.....\$295

49 Easy Transistor Projects

by *Robert M. Brown and Tom Kneitel*. This fascinating and instructive book provides complete, simple instructions for building an a-m radio, an f-m radio, light relay controls, audio amplifiers, code-practice oscillators, and test equipment—using inexpensive parts which can often be salvaged from old radio and tv sets. Most of the projects can be constructed in a single evening. Each project is complete with text, parts list, and schematic diagram. 64 pages; 5½ x 8½".
Order 20617, only.....\$175

Servicing Digital Devices

by *Jim Kyle*. Teaches you how to troubleshoot computers and associated digital devices. Along with the easy-to-understand text, servicing problems are presented to test your knowledge. Includes a description of test equipment required for troubleshooting. Explains basic principles of logic and switching circuits; briefly surveys the type of digital equipment likely to be encountered. Explains logic symbols, as well as counters, registers, adders, and comparators. Includes chapter on digital jargon, its history and peculiarities, as well as a glossary and answers to troubleshooting problems. 144 pages;
5½ x 8½". Order 20618, only.....\$325

Understanding Electronics Units and Standards

by *Farl J. Waters*. To understand electronics, it is essential to understand the terms volt, ampere, ohm, etc., the standards used to establish them, and how they are derived from the standards. This book provides such an understanding. It also discusses the fundamentals of atomic structure, electrostatic charge of the electron, and electron movement about the atom. Questions are included at the end of each chapter to reinforce understanding. 128 pages;
5½ x 8½". Order 20610, only.....\$325

These and over 300 other SAMS Books are available
from your local Electronics Parts Distributor.

COMING
NEXT MONTH

Transistor Substitution Handbook. 8th Ed.
ABC's of Electrical Soldering
How to Repair Major Appliances. 2nd Ed.



HOWARD W. SAMS & CO., INC.

4300 W. 62nd St., Indianapolis, Ind. 46268

CIRCLE NO. 95 ON READER SERVICE CARD

GET
INTO

ELECTRONICS



V.T.I. training leads to success as technicians, field engineers, specialists in communications, guided missiles, computers, radar and automation. Basic & advanced courses in theory & laboratory. Electronic Engineering Technology and Electronic Technology curricula both available. Assoc. degree in 29 mos. B. S. also obtainable. G.I. approved. Graduates in all branches of electronics with major companies. Start September. February. Dorms. campus. High school graduate or equivalent. Write for catalog.

VALPARAISO TECHNICAL INSTITUTE
Dept. RD, Valparaiso, Indiana 46383

PHOTOGRAPHY ANNUAL

A brilliant collection of the year's most stimulating photos — 212 pages — 24 in full color.
'68 \$1.50 #61 '67 \$1.50 #38
1966...\$1.25...#1

COLOR PHOTOGRAPHY

Over 150 pages of great photography... 80 pages in full color. Destined to become a collectors item! Complete technical data included.
1968...\$1.25...#66

Popular Photography's WOMAN

An exciting insight into the world of beautiful women. This 128 page collection includes complete technical data.
1968...\$1.25...#62

Order by
number from

Ziff-Davis Service Div., 595 Broadway • New York, N.Y. 10012. Enclose add'l 15¢ per copy for shipping and handling (50¢ for orders outside U.S.A.)

RADAR COUPLER

WHEN mission requirements necessitate flying in bad weather, the Air Force frequently lands its planes by means of Ground Control Approach (GCA) radar. In this method, a ground controller monitors the flight of an incoming aircraft by observing the airplane's flight path on the radar scope and "talks" the pilot into position for a safe landing. Unfortunately, rain and snow often cause interference with the X-band signals of GCA radar and sometimes make it difficult for the ground controller to distinguish the approaching aircraft from the other clutter on the radar scope.

A technique to eliminate this problem was conceived by the U.S. Air Force's Systems Engineering Group at Wright-Patterson Air Force Base, Ohio. The technique involves a special airborne receiver that acts as a cross-link between the ground-based X-band radar and an L-band air-traffic control transponder in the aircraft. The receiver picks up the X-band radar signals and generates synchronous pulses that trigger the L-band transponder. The L-band signals are received by a broad-beamed horn at the ground site and are displayed in the azimuth and elevation planes on the GCA radar's scope. Without such a cross-link device and the use of the L-band transponder (which is standard equipment on military and commercial aircraft), the system would require a special airborne transmitter.

The new device was developed by the Airborne Instrument Laboratory, a division of the Cutler-Hammer Corp. and has been designated by the Air Force the AN/ARA-62 (Beam Reinforcement Adapter). It consists of an antenna which weighs less than one pound and an amplifier-trigger pulse generator that weighs less than five pounds. The device is all-solid-state and uses microminiature techniques to achieve a high packaging density. According to AIL, the extensive use of linear and digital microcircuitry ensures the airborne unit of Mean-Time-Between-Failures (MTBF) of 1000 operating hours.

The Air Force has ordered seven of the AN/ARA-62 prototype units and will subject them to extensive reliability and environmental tests and flight tests. It is also conceivable that some of the units may find their way to Viet Nam for testing under actual combat conditions. During the monsoon season, the heavy rains force cancellation of many strikes against the Viet Cong and North Vietnamese. A system like this would help keep the fighter planes flying. ▲

Now There Are 3 Heathkit® Color TV's

The NEW Deluxe

Heathkit "227" Color TV

Exclusive Heathkit Self-Servicing Features. Like the famous Heathkit "295" and "180" color TV's, the new Heathkit "227" features a built-in dot generator plus full color photos and simple instructions so *you* can set-up, converge and maintain the best color pictures at all times. Add to this the detailed trouble-shooting charts in the manual, and you put an end to costly TV service calls for periodic picture convergence and minor repairs. No other brand of color TV has this money-saving self-servicing feature.

Advanced Features. Top quality American brand color tube . . . 227 sq. in. rectangular viewing area . . . 24,000 v. regulated picture power . . . improved phosphors for brilliant, livelier colors . . . new improved low voltage power supply with boosted B+ for best operation . . . automatic degaussing . . . exclusive Heath Magna-Shield to protect against stray magnetic fields and maintain color purity . . . ACC and AGC to reduce color fade and insure steady, flutter-free pictures under all conditions . . . preassembled & aligned IF with 3 stages instead of the usual 2 . . . preassembled & aligned 2-speed transistor UHF tuner . . . deluxe VHF turret tuner with "memory" fine tuning . . . 300 & 75 ohm VHF antenna inputs . . . two hi-fi sound outputs . . . 4" x 6" 8 ohm speaker . . . choice of installation — wall, custom or optional Heath factory assembled cabinets. Build in 25 hours.

Kit GR-227, (everything except cabinet) . . . \$42 dn., as low as \$25 mo. . . . **\$419.95**
GRA-227-1, Walnut cabinet . . . no money dn., \$6 mo. . . . **\$59.95**
GRA-227-2, Mediterranean Oak cabinet (shown above), . . . no money dn., \$10 mo. . . . **\$94.50**



Kit GR-227
\$419⁹⁵
 (less cabinet)
 \$25 mo.

Kit GRA-27
\$19⁹⁵



New Remote Control For Heathkit Color TV

Now change channels and turn your Heathkit color TV off and on from the comfort of your armchair with this new remote control kit. Use with Heathkit GR-227, GR-295 and GR-180 color TV's. Includes 20' cable.



Kit GR-295
\$479⁹⁵
 (less cabinet)
 \$42 mo.

Deluxe Heathkit "295" Color TV

Has same high performance features and built-in servicing facilities as new GR-227, except for 295 sq. in. viewing area (industry's largest picture) . . . 24,000 volt picture power . . . universal main control panel for versatile in-wall installation . . . and 6" x 9" speaker.

Kit GR-295, (everything except cabinet), 131 lbs. . . . \$48 dn., \$42 mo. . . . **\$479.95**
GRA-295-4, Mediterranean cabinet (shown above), 90 lbs. . . . no money dn., \$11 mo. . . . **\$112.50**
 Other cabinets from \$62.95.



Kit GR-180
\$349⁹⁵
 (less cabinet & cart)
 \$30 mo.

Deluxe Heathkit "180" Color TV

Same high performance features and exclusive self-servicing facilities as new GR-227 (above) except for 180 sq. in. viewing area.

Kit GR-180, (everything except cabinet), 102 lbs. . . . \$35 dn., \$30 mo. . . . **\$349.95**
GRA-180-5, table model cabinet & mobile cart (shown above), 57 lbs. . . . no money dn., \$5 mo. . . . **\$39.95**
 Other cabinets from \$24.95

Deluxe 12" Transistor Portable B&W TV - First Kit With Integrated Circuit

Unusually sensitive performance. Plays anywhere . . . runs on household 117 v. AC, any 12 v. battery, or optional rechargeable battery pack (\$39.95); receives all channels; new integrated sound circuit replaces 39 components; preassembled, prealigned tuners; high gain IF strip; Gated AGC for steady, jitter-free pictures; front-panel mounted speaker; assembles in only 10 hours. Rugged high impact plastic cabinet measures a compact 11½" H x 15¾" W x 9¾" D. 27 lbs.



Kit GR-104
\$119⁹⁵
 \$11 mo.

Kit GR-104, 27 lbs. . . . no money dn., \$11 mo. . . . **\$119.95**

No Money Down On \$25 to \$300 Orders — Write For Credit Form

13 New Kits From Heath...

New! Heathkit Wireless Home Protection System for Your Family's Safety



GD-97 Utility Transmitter for Universal Protection

GD-77 Wireless Receiver/Alarm fail-safe, always alert

GD-87 Wireless Smoke/Heat Detector-Transmitter

Applications Unlimited . . . Customize Your Own System. Here's reliable, low cost, 24-hour protection for your family and property. System warns of smoke, fire, intruders, freezing, thawing, cooling, rising or receding water, pressures . . . any change you want to be warned about. Uses unique new signaling method developed by Berkeley Scientific Labs.; exclusively licensed to Heath. Your house is already wired for this system, just plug the units into any AC outlet. "Load transmission" design (not a carrier type as in wireless intercoms) generates unusual signal that is practically unduplicable in other devices or random noise sources. Solid-state circuitry has built-in fail-safe capability to sound alarm if power fails, if power supply components in any unit fail, or if 50,000 hour bulb in smoke detector fails. Receiver/Alarm has 2800 Hz transistor alarm and receptacle for extra 117 VAC bell or buzzer to extend range, plus rechargeable battery (always kept charged) to sound alarm if power fails. Smoke-Heat Detector-Transmitter capability may be extended to other areas by adding extra heat sensors to its built-in sensor. Utility Transmitter accepts any type of switch or sensor for any purpose; examples: magnetic reed switches for doors and windows to warn of entry; step-on switches for door or driveway; micro switches with trip wire around yard; heat sensors; water pressure switches warn of pump failure; thermal switches warn of freezing in gardens, or thawing in freezers; two wires act as switch to warn of changing water levels in sump-pump wells, pools, etc. Units are small and unobtrusive in beige and brown non-reflecting velvet finish. Any number of units may be used in the system. All units feature circuit board construction; each unit takes only 3 hours to build. Operating cost similar to electric clocks. Invest in safety for your family now with this unique Heath system.

- Kit GD-77, receiver/alarm, 4 lbs. \$39.95**
- Kit GD-87, smoke/heat det.-trans., 5 lbs. \$49.95**
- Kit GD-97, Utility trans., 4 lbs. \$34.95**
(numerous accessory switches available from Heath)

New! Low Cost Heathkit 5-Band SSB-CW Transceiver



Kit HW-100
\$240.00

You asked for it . . . a 5-band version of the Heathkit "single-banders" . . . a low cost SSB transceiver for 10 or 15 meters . . . an SSB transceiver equal or superior to many wired rigs but at much lower cost. It's the new HW-100, the most SSB equipment you can get for the money. Features build-it-yourself solid-state (FET) VFO; 80-10 meter coverage; switch-selected upper or lower sideband or CW; crystal filter; full coverage on all bands with 500 kHz per band segment; smooth vernier control; built-in 100 kHz calibrator; separate offset CW carrier crystal; TALC; quiet, enclosed relays; fixed or mobile operation with accessory power supplies; 180 watts PEP, 170 watts CW input; PTT or VOX on SSB; CW transceive by VOX from keyed tone using grid-block keying; less than 100 Hz drift per hour after warmup; less than 100 Hz variation under 10% line voltage variation; receiver sensitivity less than 0.5 uv for 10 dB S+N; N ratio for SSB operation; selectivity 2.1 kHz at 6 dB down, 7 kHz at 60 dB down; image & IF rejection better than 50 dB; easy circuit board construction with one large wiring harness; handsome 2-piece green wrinkle finish cabinet. It's a winner!

Kit HW-100, 19 lbs., no money dn., \$22 mo. \$240.00

New! Heathkit High-Power Inverter for Boats, Cars, Campers

Kit
MP-14
\$99.95



Powers Color & B&W TV's, power tools, radios, phonos, lights, tape recorders, hi-fi systems, shavers, PA systems, ham & CB rigs, any small appliance except compressor-type refrigerators and units having heating elements drawing over 400 watts. Also makes good source of limited emergency power at home. Delivers 500 watts intermittent; 400 watts continuous; freq. and output adjustable for best operation; remote control-output and cables included. 29 lbs.

New! Heathkit Crystal-Controlled Post Marker Generator

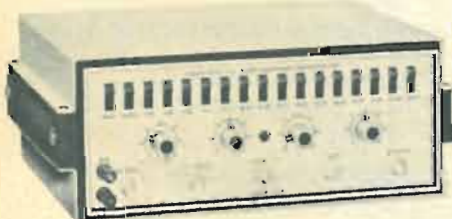

Kit IG-14
\$99.95
\$10 mo.

Fast, accurate color TV and FM alignment at the touch of a switch! 15 crystal-controlled marker frequencies. Select picture and sound IF's, color bandpass and trap freqs., 6 dB points, FM IF cent; freq. and 100 kHz points. Use up to six markers simultaneously. Birdie-type markers. Trace and marker amplitude controls permit using regular 'scope. 400 Hz modulator. Variable bias supply. Input and output connectors for use with any sweep generator. Also has external marker input. BNC connectors. Solid-state circuit uses 22 transistors, 4 diodes. Two circuit boards. Handsome new Heathkit instrument styling of beige and black in stackable design. Until now, an instrument of this capability cost hundreds of dollars more. Order your IG-14 now, it's the best investment in alignment facilities you can make.

Kit IG-14, 8 lbs., no money dn., \$10 mo. \$99.95

New! Low Cost Heathkit 5 MHz 3" Scope

Kit IO-17
\$79.95



Here is the wideband response, extra sensitivity and utility you need, all at low cost. The Heathkit IO-17 features vertical response of 5 Hz to 5 MHz; 30 mv Peak-to-Peak sensitivity; vertical gain control with pull-out X50 attenuator; front panel 1 volt Peak-to-Peak reference voltage; horizontal sweep from internal generator, 60 Hz line, or external source; wide range automatic sync; plastic graticle with 4 major vertical divisions & 6 major horizontal; front mounted controls; completely nickel-alloy shielded 3" CRT; solid-state high & low voltage power supplies for 115/230 VAC, 50-60 Hz; Zener diode regulators minimize trace bounce from line voltage variations; new professional Heath instrument styling with removable cabinet shells; beige & black color; just 9 1/2" H. x 5 1/2" W. x 14 1/2" L.; circuit board construction, shipping wt. 17 lbs.

See 300 More in FREE Catalog

New! Heathkit/Kraft 5-Channel Digital Proportional System with Variable Capacitor Servos

System Kit GD-47

\$219.95

\$21 mo.

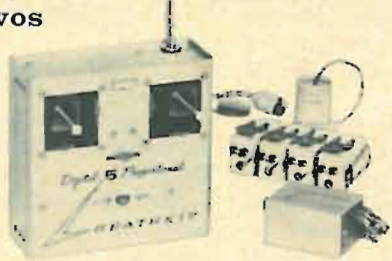

This Heathkit version of the internationally famous Kraft system saves you over \$200. The system includes solid-state transmitter with built-in charger and rechargeable battery, solid-state receiver, receiver rechargeable battery, four variable capacitor servos, and all cables. Servos feature sealed variable capacitor feedback to eliminate failure due to dirty contacts, vibration, etc.; three outputs: two linear shafts travel 1/4" in simultaneous opposite directions plus rotary wheel. Specify freq.: 26.995, 27.045, 27.145, 27.195 MHz.

- System Kit GD-47, all of above, 5 lbs. \$219.95
- Kit GDA-47-1, transmitter, battery, cable, 3 lbs. \$86.50
- Kit GDA-47-2, receiver, 3 lbs. \$49.95
- GDA-47-3, receiver rechargeable battery, 1 lb. \$9.95
- Kit GDA-47-4, one servo only, 1 lb. \$21.50

World's Most Advanced Stereo Receiver



Kit AR-15
\$329.95
(less cabinet)
\$28 mo.

Acclaimed by owners & experts for features like integrated circuits & crystal filters in IF amplifier; FET FM tuner; 150 watts music power; AM/FM and FM stereo; positive circuit protection; all-silicon transistors; "black magic" panel lighting; and more. Wrap-around walnut cabinet \$19.95.

- Kit AR-15 (less cab.), 34 lbs. . . \$33 dn., \$28 mo. \$329.95
- Assembled ARW-15, (less cab.), 34 lbs. . . \$50 dn., \$43 mo. \$499.50

New! Solid-State Portable

So Handy, So Low Cost we call it "every man's" meter. Just right for homeowners, hobbyists, boatowners, CBER's, hams . . . it's even sophisticated enough for radio & TV servicing! Features 12 ranges . . . 4 AC & 4 DC volt ranges, 4 ohm ranges; 11 megohm input on DC, 1 megohm input on AC; 4 1/2" 200 uA meter; battery power; rugged polypropylene case and more. Easy 3 or 4 hour kit assembly. 4 lbs.

Volt-Ohm-Meter

Kit IM-17
\$19.95



What would you expect to pay for a Vox "Jaguar" Combo organ with a 180-watt 3-channel amp?

**\$1000? \$1250?
\$1500? More?**



Kit TOS-1
Organ, Amplifier
& Speaker Kits
(240 lbs.)
\$598.00



Kit TOS-2
Organ Kit,
Assembled
Amplifier &
Speaker (240 lbs.)
\$698.00

You can get both for only \$598 during this Special Heathkit Offer!

Now you can get this famous professional combo organ with a versatile high-power piggy-back amp. and matching speaker system for just a little more than you'd expect to pay for the "Jaguar" alone! The Heathkit/Vox "Jaguar" is solid-state; two outputs for mixed or separated bass and treble; reversible bass keys for full 49 key range or separate bass notes; bass volume control; vibrato tab; bass chord tab; four voice tabs (flute, bright, brass, mellow); keyboard range C₂ to C₆ in four octaves; factory assembled keyboard, organ case with cover, and stand with case. Also available separately; you'll still save \$150 (order Kit TO-68, \$349.95).

The Heathkit TA-17 Deluxe Super-Power Amplifier & Speaker has 180 watts peak power into one speaker (240 watts peak into a pair); 3-channels with 2 inputs each; "fuzz", brightness switch; bass boost; tremolo, reverb; complete controls for each channel; foot switch; 2 heavy duty 12" speakers plus horn driver. Also available separately kit or factory assembled (Kit Amplifier TA-17, \$175; Assembled \$275; Kit Speaker TA-17-1 \$120; Assembled \$150; Kit TAS-17-2, amp. & two speakers \$395; Assembled TAW-17-2, amp. & two speakers \$545).

New! Heath/Mitchell COLORVAL Dark-room Computer . . . Kit or Assembled

Kit PM-17
\$89.95
\$9 mo.



Colorval takes the work out of color printing, leaves the creativity to you. Colorval is easy to set up . . . you "program" the scan filter pack for the type of film, paper, and equipment you use . . . we show you how. Unique Color Probe allows visual determination of ideal enlarger filter combination. Color Wheel and table shows what filter changes are needed. Exposure Probe scans shadows and highlights; exposure scale on Computer indicates proper contrast for color and b/w printing. Get started in color the right way, quickly, easily.

- Kit PM-17, 6 lbs., no money dn., \$9 mo. \$89.95
- Assembled PMW-17, 6 lbs. . . no money dn., \$13 mo. . . \$125.00



NEW FREE 1968 CATALOG!

View with more kits, more color. Fully describes these along with over 300 kits for stereo hi-fi, color TV, electronic organs, electric guitar & amplifier, amateur radio, marine, educational, CB, home & hobby. May coupon or write Heath Company, Benton Harbor, Michigan 49022.

HEATH COMPANY, Dept. 15-4
Benton Harbor, Michigan 49022
In Canada, Daystrom Ltd.

Enclosed is \$ _____, including shipping.

Please send model (s) _____

Please send FREE Heathkit Catalog.

Please send Credit Application.

Name _____

Address _____

City _____

State _____

Zip _____

Prices & specifications subject to change without notice.

CL-321

MANUFACTURES A COMPLETE LINE OF

FAIL SAFE CIRCUIT BREAKERS

IN MOLDED BLACK PLASTIC CASE

CUT AWAY MODEL



Model Numbers FA1.5 to FA7

When Red Button is depressed, contacts remain open, circuit is refused ONLY after Red Button is released.

RECOGNIZED UNDER THE COMPONENT PROGRAM OF UNDERWRITERS' LABORATORIES, INC.

CIRCLE NO. 88 ON READER SERVICE CARD

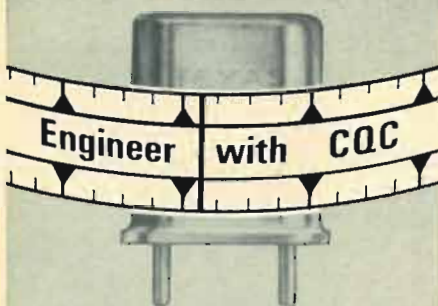

MORE CONTROL

Control of quality throughout precision manufacturing gives you crystals that assure exact frequency control.

MORE RELIABILITY

You'll stay on frequency better with CQC. And, you can rely on your CQC dealer to fill your needs promptly.

See your dealer for prices and data on CQC



TEXAS CRYSTALS

Div. of Whitehall Electronics
 1000 Crystal Drive
 Fort Myers, Fla. 33901
 Plants in Fort Myers and Los Angeles

Circle No. 195 on Reader Service Card

New Filter Designs

(Continued from page 31)

type of filter and a certain number of poles. Since the bandwidth may be vastly different for different designs, we normalize this information and allow it to be added later.

Table 1 is a list of the normalized unloaded "Q" required as a function of the number of poles and type of filter. If the design is a low-pass type, these "Q's" are the minimum required for each element of the filter. If a band-pass design is used, the normalized "Q" must be multiplied by the total filter "Q". This, then, is the minimum "Q" required.

To illustrate how all of these aspects dovetail, let us design a filter for the band from 2 to 30 MHz with a v.s.w.r. of no greater than 1.5:1, an attenuation at least 35 dB at twice the -3 dB bandwidth at 50 ohms impedance. A v.s.w.r. of 1.5 represents a ripple of 0.177 dB (see Fig. 3) so a ripple of 0.1 dB is acceptable. The shape factor will be the limiting factor for the minimum number of elements we may use. A good choice is a 5-element Chebyshev, 0.1 dB ripple filter. See Fig. 4 below.

The normalized elements are found to be: $L1=1.15 \mu\text{H}$, $C2=1.39 \mu\text{F}$, $L3=1.97 \mu\text{H}$, $C4=1.39 \mu\text{F}$, and $L5=1.15 \mu\text{H}$.

De-normalizing by the following for-

mulas gives us values for L' and C' :

$$L' = \frac{RL}{2\pi(-3 \text{ dB B.W.})} = \frac{50L}{6.28 \times 28}$$

$$C' = \frac{C}{R \times 2\pi(-3 \text{ dB B.W.})} = \frac{C}{50 \times 6.28 \times 28}$$

We get $L'=0.327 \mu\text{H}$, $C'=156 \text{ pF}$, $L3'=0.560 \mu\text{H}$, $C4'=156 \text{ pF}$, and $L5'=0.327 \mu\text{H}$.

This gives us the low-pass prototype filter from which we can get the final bandpass design. This is achieved by resonating the low-pass elements at the geometrical mean frequency of the band we wish to filter, or

$$f_0 = \sqrt{f1 \times f2} = \sqrt{2 \times 30} \text{ MHz} = 7.74 \text{ MHz}$$

The additional elements required are thus found to be: $C1'=1400 \text{ pF}$, $L2'=2.7 \mu\text{H}$, $C3'=725 \text{ pF}$, $L4'=2.7 \mu\text{H}$, and $C5'=1400 \text{ pF}$.

The filter is of the ladder type and is shown along with its response in Fig. 4.

In practice, this filter would have to be built and aligned. To do this, certain changes are made. One is in the capacitors, two capacitors would be used, one fixed and the other a variable unit which could trim the fixed unit to the precise value required. The inductors would either be variable units or precision toroids; both could be pre-adjusted on a "Q"-meter to the exact value and then installed. ▲

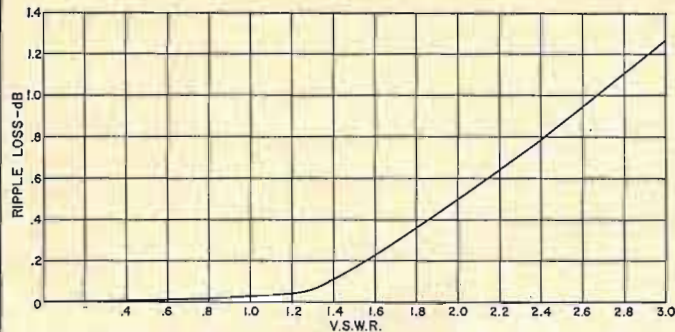

Fig. 3. The amount of loss due to ripple for various v.s.w.r.'s.

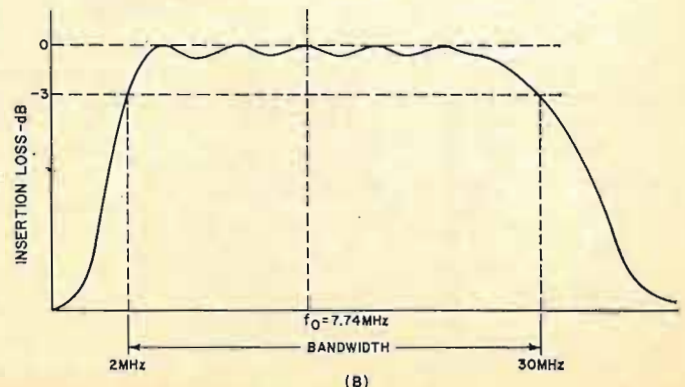
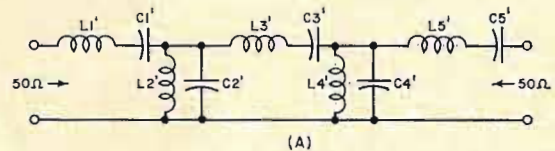

Fig. 4. The filter employed along with its frequency response.

Technical Institute Graduate (Continued from page 30)

Discussion of static magnetic and time-varying electromagnetic fields leading up to electromagnetic propagation and some elementary applications. Magnetic polarization and circuits. Ferromagnetic materials. Motion of charged particles in static fields. Faraday's law, displacement current, continuity equation. Maxwell's equations and boundary conditions; relation between field and circuit theory. Plane waves, polarization and reflections; traveling and standing waves. Skin effect. Poynting's theorem. Simple waveguides and resonators.

It is obvious that there must be a fairly substantial overlap between the subject matter presented by the technical institutes and that presented by the universities.

The next area to be considered is automatic control systems. Technical Institute A offers a course in this area which has the description:

Automatic Control Systems. General aspects: general theory, components, mathematical tools, stability criteria, design considerations. Servo components: error detectors, synchros, potentiometers, amplifiers, electric and hydraulic drive equipment, transducers. Transfer functions; stability theory: Bode plots, Routh's method, Nyquist plot. Transient response and the effect of varying parameters.

Technical Institute C requires two courses on this subject. The first is described as:

Control Systems Components: Introduces the students to characteristics and performance of linear control systems with one or more feedback loops. The functions and properties of various components encountered in control systems are studied. These include servo motors, generators, synchros, servo amplifiers, and error detectors. Differential equations, Laplace transform methods, and pole-zero techniques are employed.

The second course is described as:

Control Systems: Presents a more intensive study of servo systems by means of frequency loci, Nyquist, root locus, Bode, and Nichols plots. Stability criteria are developed and methods of stabilization and system synthesis are considered. Pole-zero s -plane analysis is used.

These may be compared with a course required by University A which is listed as:

Description of dynamic systems in frequency and time domains; stability analysis; analysis and design in the frequency domain (Bode, Nyquist, root locus, etc.).

University B offers a course described as:

A study of linear feedback control systems, their physical behavior, dynamical analysis, and stability. Laplace transform, frequency spectrum, and root locus methods are employed. Introduction to system design and compensation.

Again, it is seen that striking similarities exist.

Similar and even more striking comparisons can be made in the areas of electronics and circuit theory. It was the author's intention to select areas in which the comparison would be most unfavorable to the technical institutes so that their surprising strength even in these areas where the most advanced mathematical techniques are employed could be demonstrated.

Important Conclusions

The following conclusions may be reached from the preceding survey. *First*, the technical institute graduate of the type of program described in this article is a highly trained professional. *Second*, he has received instruction in his major which is in some respects superior to that of an engineer. *Third*, organizations employing technical institute graduates must be particularly vigilant to utilize them in tasks which are in keeping with their training and capacity. Their training is more than adequate to relieve the organization's professional engineering staffs of many duties. *Fourth*, the organization which finds itself short of engineering personnel should carefully examine the job vacancies to determine the precise technical requirements of the job. In a surprising number of cases, it will be found that the demands of the job can be more than met by the technical institute graduate. ▲

We defy competition

to top Oxford quality, variety, delivery, and prices!

Here are the speakers with the quality features demanded for today's critical sound requirements. Extra heavy ceramic magnets for wider range, with Oxford's exclusive "Floating Suspension Surround" the permanently flexible edge that extends the low frequency spectrum without undesirable hangover, assuring smoother mid-range, brilliant high frequency response.



Paging and Talk Back Speakers



Public Address Speakers



"TEMPO" Hi-Fi Speaker



All Weather Speakers



Replacement Speakers



Professional Musical Instrument Speaker

Match your needs from a full range of speakers for new highs in high fidelity performance. Best of all, they're available to you now—

OXFORD,
of course.



Write for complete information today!

**OXFORD TRANSDUCER
COMPANY**

A Division of Oxford Electric Corporation
3911 S. Michigan Ave., Chicago, Ill. 60653





mystery: **where
did all
the color
GO?**

here's the missing link in color

Belden's Color Twins deliver full color power all the way to the set. Eliminate many causes of lead-in signal loss. Deliver a ghost-free picture. ■ Belden's COLOR TWINS are: 8290† Shielded Permohm with Beldfoil* for congested or high interference areas; and 8285† Unshielded Permohm for rural, low-signal-strength areas. ■ 8290 with patented Beldfoil shielding prevents line pick up of interference signals that produce ghosts and electrical interference. 8285 Permohm's conductors are encapsulated in low-loss cellular polyethylene to maintain a strong signal in all weather conditions, especially in fringe reception areas. ■ 8290 Shielded Permohm is designed so that you can install it without expensive transformers, connectors, and "stand offs." You can even tape it to a mast or run it through a rain gutter. ■ With Permohm lead-ins, the set gets the full color power of the signal (full power for UHF or VHF, too.) Now owners can get the kind of picture they bought a color set for. You get the laurels.

BELDEN CORPORATION
P.O. Box 5070-A • Chicago, Illinois 60680

reception!

8285[†]

Belden
Unshielded Permohm
for rural areas.

Call your Belden distributor about the
Color Twins—



BELDEN

8285 PERMOHM

8290^{††}

Belden
Shielded Permohm
with Beldfoil
for congested areas.

ALL CHANNEL TV

don't forget
to ask them
what else needs
fixing?

*Belden Trademark Reg. U.S. Patent Office †Belden Patent No. 2,782,251 ††Belden Patent No. 2,782,251 and Pat. Pending

One of a series of brief discussions
by Electro-Voice engineers



Mass-produced phonograph cartridges must meet a number of criteria to be accepted by the phonograph industry. Among them are high performance, a high degree of uniformity, and low cost. Yet the complexity of past cartridge designs made the attainment of these goals a constant struggle. At Electro-Voice, a basic program of re-evaluation of cartridge design has resulted in a drastic reduction of complexity for a modern stereo ceramic cartridge.

Comparing the new cartridge* with the old, we find it composed of just five assemblies, as opposed to the 12 parts needed in previous designs. This simplification resulted in no degradation of performance, but did contribute to a significant improvement in uniformity and a sharp reduction in assembly time and cost.

A key achievement of the program was an improved element assembly. In the past, hundreds of rubber back pads and yokes were molded at once, then each pad was assembled to a ceramic element. Finally, a pair of elements were joined by a yoke before insertion in the cartridge body. The hand assembly, plus the multitude of dies made variations in mechanical positioning inevitable.

With the new design, both ceramic elements are loaded into an eight-station rotating die that permits molding the thermoplastic yoke and back pad assembly directly to the ceramic elements in one operation. No additional assembly is needed, and the lower number of dies reduces variations in size and positioning.

The external case design has also been simplified, and snaps together without the use of fasteners. Perhaps more dramatic, however, is the simplification of electrical contacts. Normally a set of external contacts press against the sides of the elements to provide output termination.

With the new design, however, the ends of the elements themselves extend from the back of the cartridge. A mating plug, wired directly into the tone arm, is supplied with spring-loaded wiping contacts. When the cartridge is inserted, the plug terminals make direct, positive contact with the sides of the elements, thus eliminating all intermediate contact surfaces and reducing the incidence of intermittents.

In keeping with today's designs, the new cartridge is quite small, and well suited to a variety of mounting schemes. Final proof of design success is in the ready acceptance of this new concept by phonograph manufacturers. Nevertheless, work continues on even more sophisticated approaches to phono transducer design.

*Patents applied for.

For reprints of other discussions in this series,
or technical data on any E-V product, write:
ELECTRO-VOICE, INC., Dept. 483N
629 Cecil St., Buchanan, Michigan 49107



CIRCLE NO. 114 ON READER SERVICE CARD
86

NEW R.F. STANDARD

GHz measurement device
upgrades NBS calibrations.

GIGAHERTZ radio-frequency voltages and currents in some of the new communications and radar systems must be measured precisely if their performance is to be known. To do this, the National Bureau of Standards has developed a new instrument called a Bolovac. It can measure voltage and current at frequencies up to 20 GHz with accuracy, simplicity, and ease. The Bolovac is now the standard against which instruments sent to the Laboratory for calibration are compared in the 1 to 10 GHz region.

At GHz radio frequencies, there is a particular mensuration problem. The radio wavelength approaches the dimensions of electrical paths within the measurement instrument so care must be taken to prevent the measurement from changing the system being calibrated.

In the past, bolometric methods have been used to measure power. Bolometry makes use of the fact that most materials heat up when they absorb r.f. energy and thus undergo a change in resistance.

In the bolometric method, a sensing element is heated by passing a biasing current through it. When the element is subjected to an r.f. field, the amount by which the biasing current must be reduced to bring the element back to its reference resistance level is a function of the amount of r.f. power that is absorbed.

Typical bolometers use a barettor, a fine resistance wire, or a thermistor, a semiconductor material, as sensing elements.

The Bolovac uses a combination of a bolometric head and coaxial transmission line to measure r.f. voltage and current.

The power-sensitive unit of the bolometer is a conductive film, in the shape of two half-discs, deposited on an insulating disc through which the center coaxial conductor runs. The greater the r.f. power flowing through the device, the more power is absorbed by the two film areas and the greater their resistance becomes. An audio-frequency or d.c. source can be used to bias the Bolovac.

The NBS claims that the Bolovac can measure microwave power transmission in a uniform line with greater accuracy than most calorimetric techniques. Also, since the disc d.c. and r.f. impedances are essentially the same, the matching procedures required with the usual bolometric head are not needed. ▲

No dealer stocks
everything.

No salesman knows
everything.



But the 1968 STEREO/HI-FI DIRECTORY does!

It's a giant 182 page buyer's guide to virtually every new audio component on the market today. Over 1600 products in all! From amplifiers to complete hi-fi systems to tape cartridge recorders and players for your home, car and boat. All the latest offerings from 176 manufacturers are fully detailed and illustrated for your "shop-at-home" convenience.

Every technical specification, dimension, special feature, optional accessory, price and model number is at your fingertips—to help you compare similar items, feature for feature, dollar for dollar and decide which is best for you. Before you buy!

Forget the guesswork, costly mistakes, store-to-store treks and "after-you-get-it-home" disappointments. With the 1968 STEREO/HI-FI DIRECTORY as your guide, you'll zero-in on the equipment you want, buy it with confidence—and know you're getting the greatest value for your money.

The price for this valuable "encyclopedia" of hi-fi information? Just \$1.25. A small investment, indeed, for such an essential component of your listening enjoyment. So don't delay. Use the coupon below to order your copy of the 1968 STEREO/HI-FI DIRECTORY today!

CONTENTS INCLUDE
Special 8-page section on: ● How to choose components ● How to compare prices, features specifications ● Exclusive state-of-the-art report on componentry ● PLUS an incisive analysis of the controversial 8 track, 4 track and cassette tape cartridges. . . . Comments and clues on which design holds the most promise for the future.

Individual directories for amplifiers / changers / turntables / cartridges and tonearms / receivers/tuners/tape machines (including video recorders and cartridge units) / speakers / integrated systems / antennas / microphones / cabinets.

The 1968 STEREO/HI-FI DIRECTORY is available in a splendid deluxe edition. Rugged Leatherflex cover provides lasting protection yet is softly textured and gold-embossed for the look of elegance. A collector's item—a superb addition to your permanent reference library. Just \$3 postpaid.

ZIFF-DAVIS SERVICE DIVISION • DEPT. SD
595 Broadway • New York, N. Y. 10012

YES: Send me the new 1968 STEREO/HI-FI DIRECTORY as checked below:

\$1.25 enclosed, plus 15c for shipping and handling. Send me the regular edition. (\$1.75 for orders outside the U.S.A.)

\$3.00 enclosed. Send me the Deluxe Leatherflex-bound edition, postpaid. (\$3.75 for orders outside the U.S.A.) Allow three additional weeks for delivery.

print name _____ EW-48

address _____

city _____

state _____ zip code _____

PAYMENT MUST BE ENCLOSED WITH ORDER

EW Lab Tested
(Continued from page 6)

ter than 20 dB over the range of 30 to 10,000 Hz. The FM distortion at 75-kHz deviation was 0.75%.

The audio power ratings of the Studio Pro 120 are specified, at 4-ohm load impedance, as 60 watts per channel IHF (dynamic) power. The continuous power is rated at 30 watts per channel at 0.3% harmonic distortion. Our standard measurement procedure is to use 8-ohm loads, and the receiver acquitted itself very well. We measured less than 0.65% distortion between 50 and 10,000 Hz at 30 watts per channel, with both channels driven. Full power measurements could not be made above and below these limits, due to the tripping of the protective circuit breakers. A rough and rapid check of the available power at the point of waveform clipping showed that the output into 4 ohms was about 143% of the 8-ohm output, and the 16-ohm output was about 56% of the 8-ohm power.

The IM distortion was less than 0.35% for all levels below 20 watts, and the 1000-Hz harmonic distortion did not exceed 0.2% until the breakers operated at 25 watts. This is evidently a conservative safety limit established by the manufacturer.

The tone controls had good range and did not affect the mid-frequency response between 400 and 2000 Hz. On our test unit, the RIAA phono equalization was ± 1 dB from 100 to 20,000 Hz, rising to +3 dB at 30 Hz. The NAB tape head equalization was within ± 1.5 dB from 150 to 20,000 Hz, falling to -5.5 dB in the 30- to 40-Hz region. Subsequent correspondence with the manufacturer indicated that two capacitors in the equalization circuit had been transposed in this early sample and that with the correct values the low-frequency errors in both equalization curves would be reduced substantially. The low filter had a 6 dB/octave slope below 100 Hz, and the high filter had a 12 dB/octave slope above 8000 Hz. Both worked well and had little effect on the desired program.

The amplifiers had high gain, yet

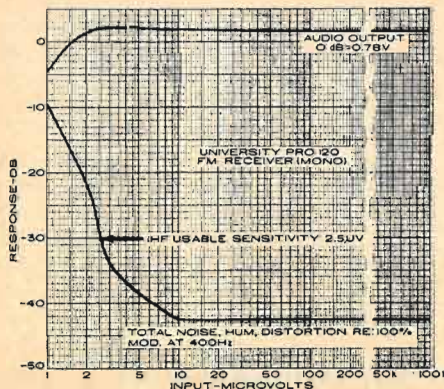

INSTALL TOMORROW'S IGNITION SYSTEM ON YOUR CAR TODAY

The Judson Electronic Magneto

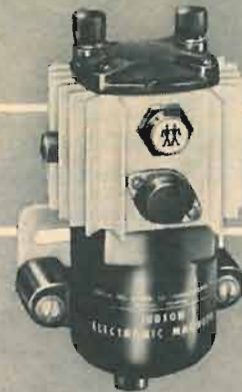

WHY DRIVE A LATE MODEL CAR WITH A 1910 IGNITION SYSTEM?

WHAT IT DOES: eliminates frequent tune-ups • triples plug and point life • provides better and smoother performance • gives you positive ignition for turnpike driving • develops all the power your engine can produce • reduces fuel consumption and pays for itself • you need one on your car now.

Do not confuse the Judson Electronic Magneto with ordinary transistorized ignition systems. Guaranteed to outperform and outlast any electronic ignition system on the market. Sensibly priced at only \$49.50. Can be installed within twenty minutes.

Write today for Literature.

JUDSON

RESEARCH AND MFG. CO.
CONSHOHOCKEN, PENNA.



CIRCLE NO. 107 ON READER SERVICE CARD

Electronics World SUBSCRIBER SERVICE

Please include an address label when writing about your subscription to help us serve you promptly. Write to: Portland Place, Boulder, Colorado 80302

CHANGE OF ADDRESS:

Please let us know you are moving at least 4 to 6 weeks in advance. Affix magazine address label in space to the right and print new address below. If you have a question about your subscription, attach address label to your letter.

TO SUBSCRIBE: Check boxes below.

- New Renewal
 5 years \$21 3 years \$15 1 year \$6

SPECIFY: Payment enclosed—You get 1 extra issue per year as a bonus! Bill me later.

If you have no label handy, print OLD address here.

name _____ please print
address _____
city _____
state _____ zip-code _____

AFFIX LABEL HERE
(Add'l postage: \$1 per year outside U.S., its possessions & Canada.)

name _____ please print 0202

address _____

city _____

state _____ zip-code _____

FREE!

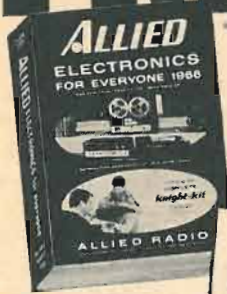

ALLIED
NEW 1968
CATALOG

518
PAGES

SAVE ON:

- Famous Knight-Kits®
- Stereo Hi-Fi
- Tape Recorders, Tape
- CB 2-Way Radios
- Walkie-Talkies
- FM-AM & AM Radios
- Shortwave Receivers
- Portable TV
- Phonographs
- Amateur Gear
- Intercoms & PA
- Automotive Electronics
- Test Instruments
- TV Antennas & Tubes
- Power Tools, Hardware
- Tubes, Transistors
- Parts, Batteries, Books

TOP SAVINGS ON
THE BEST IN
ELECTRONICS
FOR EVERYONE

Shop by mail and save at Allied, world's largest electronics headquarters. Hundreds of money-saving values. NO MONEY DOWN. Up to 2 years to pay!

MAIL COUPON
BELOW

ALLIED RADIO, Dept. 1D
P.O. Box 4398, Chicago, Ill. 60680

NAME (Please Print)

ADDRESS

CITY

STATE

ZIP

CIRCLE NO. 125 ON READER SERVICE CARD

Audio-Color
Lets you see your music



ASSEMBLED
\$54.95

KIT FORM
\$44.95

\$5 DOWN — \$5 MONTH

Walnut finished cabinet included
Shipped REA Collect

Easy to build, easy to install. All transistor AUDIO-COLOR adds a visual dimension to musical enjoyment. A brilliantly moving panorama of color casts dancing images on a soft frosted screen, reflecting rising and falling volume with each beat of the music. Here's a truly unique and exciting new musical experience. Make check or money order to CONAR.

SEND FOR FREE CONAR CATALOG

CONAR
Division of National Radio Institute
Dept. D88C, 3939 Wisconsin Avenue, Washington D. C. 20016

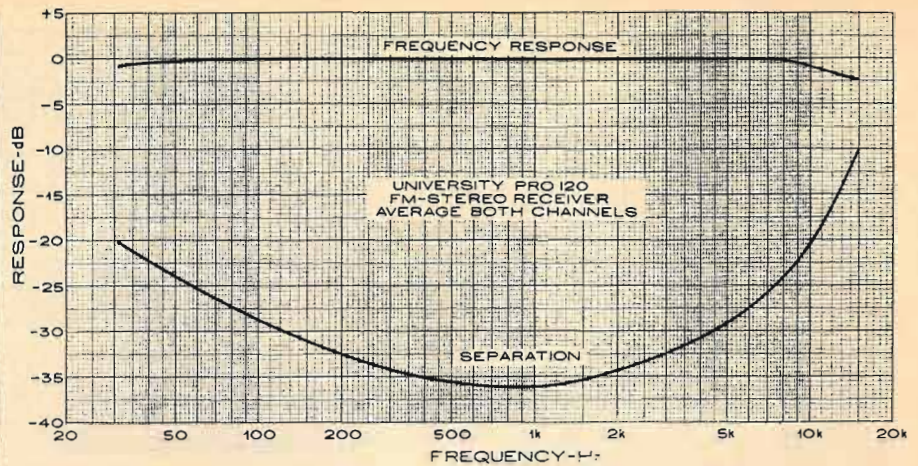

were very quiet. Only 1.85 millivolts were needed to drive the amplifier to 10-watts output through the phono inputs, yet the hum and noise were -64 dB referred to 10 watts (a totally inaudible level under any practical operating conditions). The hum on the high-level inputs was unmeasurable, being less than -80 dB. On the tape-head inputs, it was -48.5 dB. These figures indicate very fine performance.

The *University Studio Pro 120* is housed in a brushed anodized metal case, finished in satin gold color. Ac-

cessory walnut end plates are available and these add considerably to the appearance of the receiver. The receiver is priced at \$379.50, less the side panels. As the specifications and measured performance indicate, it is a very fine unit, with more than adequate sensitivity and power for almost any situation. The warranty of 2 years on parts and six months on both parts and labor confirms our impression of its conservative design, which withstood all the abuse which our testing procedures require, leaving it unscathed. ▲

BSR McDonald 600/M44-E Automatic Turntable

For a copy of manufacturer's brochure, circle No. 22 on Reader Service Card.



WHEN we reported on the *BSR McDonald 500* automatic turntable in the January, 1967 issue, we noted that it brought to the \$50 price bracket a number of features found only in more expensive record players. The new *BSR McDonald 600* represents a similar advance, offering in addition to the features of the Model 500, an adjustable anti-skating device and a substantially lower rumble level.

The Model 600 is a four-speed automatic turntable with interchangeable manual and automatic spindles. The lightweight aluminum arm has a three-piece counterweight which can balance virtually any cartridge from the lightest ceramic type to heavier magnetic cartridges. Tracking forces from 0 to 6 grams can be set by a calibrated knob with click stops at 1/3-gram intervals.

The anti-skating dial is set to correspond with the tracking force, and

applies an outward torque to the arm, equalizing the effective tracking forces on the inner and outer groove walls. A cueing or pause lever raises and lowers the arm at any point on the record, without disturbing the operation of the changer. A unique feature is the automatic arm lock which releases when the unit goes into operation.

The model we tested is a complete, almost "ready-to-use" record player. It is supplied mounted on a walnut-finished wooden base, with a tinted plastic dust cover, and a *Shure M44-E* elliptical-stylus stereo cartridge installed in the arm.

In setting the tracking force, we found that a visually horizontal arm was not a guarantee of correct balance, and that serious tracking force errors could result from such an assumption. However, when the force was set at any point, such as 2 grams, with an external stylus-force gauge, the dial calibrations were accurate to within the 1/3-gram resolution of the adjustment over its full range.

The anti-skating compensation was quite effective in reducing distortion on the channel corresponding to the outer groove wall, when tracing high-velocity test-record bands. The recommended setting of the knob was satisfactory, although we found that a setting about 1 gram higher was slightly more effective. The cueing control is capable of returning the stylus to the

groove which it left. However, it must be operated gently and lowered slowly since it is not viscous damped.

The turntable ran about 1% fast, but was not affected by wide variations in line voltage. To our surprise, the entire mechanism started and operated properly with any line voltage from 80 to 140 volts, a testimony to the conservative rating of the four-pole induction motor used.

The wow was about 0.1% at all speeds, while the extremely low flutter was between 0.03% and 0.05%. The rumble of the Model 600 was about 5 dB less than we measured on the less-expensive Model 500. It was -28 dB, including both vertical and lateral components, and -32 dB in the lateral plane. This is sufficiently low as to be inaudible unless the system is operated at high volume levels with speakers capable of reproducing the lowest frequencies.

The tonearm had a tracking error of less than 0.5 degree per inch of record radius, between radii of 2.5 inches and 6 inches. This is typical of well-designed arms of this size. The arm resonance with the *Shure M44-E* cartridge installed was at 18 Hz, with an amplitude of only 1.5 dB.

In use tests, the mechanical operation of the *BSR McDonald 600* was flawless. The cartridge, an excellent medium-priced model, sounded first rate and the entire record playing system (including deluxe base and deluxe dust cover) represents a good value at its catalogued price of \$89.50. ▲

"PROJECT TRANSITION"

A Department of Defense program to teach civilian skills to military personnel awaiting discharge will include the Service Technician Development Program (STDP) which the EIA has developed and is operating.

Dubbed "Project Transition," the new program aims at preparing exiting servicemen for immediate entry into civilian occupations via specialized short-term training courses.

The STDP is the long-term manufacturer-sponsored program to increase the numbers and improve the training of consumer electronic service technicians. It will conduct one of the first of the DOD's programs in the Chicago area for Army and Navy personnel.

EIA's Director of Education and Training for the STDP program, Richard W. Tinnell, has announced that the program will be expanded to bases in New Jersey, Virginia, North Carolina, Texas, California, Indiana, and Kentucky once the pilot program in Chicago is underway.

The Division's STDP staff will initiate and coordinate manufacturer cooperation in the venture. Arrangements are being made for industry to loan equipment to the project while the DOD will provide facilities and cooperate with the STDP in selecting and ultimately placing successful candidates in industry. ▲

Here's a remarkably stable, completely portable, all solid-state, battery operated voltmeter. Naturally it's an RCA VoltOhmyst®

Eliminate warm-up time! Eliminate zero-shift that can occur in tube-operated voltmeters! RCA's new **WV-500A** VoltOhmyst is an all solid-state, battery operated, completely portable voltmeter that is ideal for service, industrial, and lab applications. Seven overlapping resistance ranges measure from 0.2 ohm to 1000 megohms. Eight overlapping dc-voltage ranges measure from 0.02 volt to 1500 volts (including special 0.5 dc volt range), ac peak-to-peak voltages of complex waveforms from 0.5 volts to 4200 volts, and ac (rms) voltages from 0.1 to 1500 volts. Input impedance of all dc ranges is 11 megohms.

All measurements are made with a sturdy, wired-in, single-unit probe with fully shielded input cable. The probe is quickly adapted to either dc measurement or ac and resistance measurement by a convenient built-in switch. And an accessory slip-on high-voltage probe is also available to make possible measurements up to 50,000 dc volts.

See your Authorized RCA Test Equipment Distributor, or write RCA Electronic Components, Commercial Engineering Department, Section C41-WA, 415 South Fifth Street, Harrison, New Jersey.

Solid-state reliability and convenience for only \$75.00*.

*Optional distributor resale price. Prices may be slightly higher in Alaska, Hawaii, and the West.

RCA



CIRCLE NO. 84 ON READER SERVICE CARD

BOOK REVIEWS

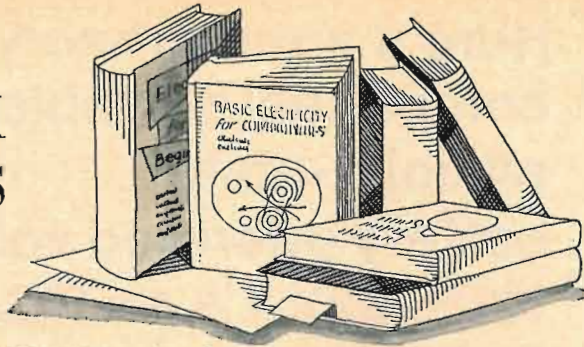

"HOW TO USE SIGNAL GENERATORS" by John D. Lenk. Published by *John F. Rider Publisher, Inc.*, New York. Three volumes. Price \$3.25 each. Soft cover.

These three volumes are available separately and can be chosen to meet the needs of the individual user. "How to use Signal Generators in Color-TV Servicing" is a 92-page manual which discusses basic operating principles; operating controls and basic operating procedures; testing and calibrating color generators; purity, convergence, and linearity adjustments; testing color sync characteristics; testing chroma demodulation characteristics; testing matrix circuit characteristics; and miscellaneous applications.

The 118-page manual for using signal generators in radio/TV, hi-fi servicing covers basic operating principles; operating controls and basic operating procedures; testing and calibrating shop-type generators; testing TV antenna systems; testing an AM receiver; testing an FM receiver, testing a TV receiver; and basic amplifier tests.

The final volume, on using signal generators in the laboratory, outlines features of laboratory-type signal generators; swept-frequency attenuation measurements; swept-frequency impedance and power measurements; frequency measurements with sweep techniques; time domain reflectometry techniques with pulse generators; pulse generator techniques, checking electronic components; and using dip adapters.

All three volumes include line drawings, hook-up diagrams, partial schematics, panel views, and other illustrative material to supplement the author's lucid textual explanations.

"RCA LINEAR INTEGRATED CIRCUITS" compiled and published by *RCA Electronic Components and Devices*, Harrison, N.J. 07029. 349 pages. Price \$2.00. Soft cover.

This expanded and updated IC manual (Technical Series IC-41) includes the latest available information on design, packaging, and applications of linear IC's.

This handbook is intended as a guide for circuit and system designers in determining optimum design specifications with regard to IC capabilities and system requirements. The manual will also

be of interest to anyone concerned with linear integrated circuits.

The manual is divided into five main sections covering general considerations, the basic differential-amplifier configuration for linear IC's, integrated-circuit operational-amplifier configurations, descriptions and applications of RCA's linear IC's, and technical data including detailed ratings and characteristics for the company's complete line of linear IC's.

"CATV SYSTEM MAINTENANCE" by Robert B. Cooper, Jr. Published by *TAB Books*, 18 Frederick Rd., Thurmont, Md. 21788. 191 pages. Price \$12.95. Soft cover.

This is a practical guide to all phases of CATV system maintenance—from the antenna to the receiver. The text includes antenna construction techniques, troubleshooting the system, data on system design, and, particularly, maintenance. Information on how to locate and correct equipment failures, tips on how to eliminate various types of interference and radiation problems at the head end, "how-to" information on pole-line mechanics and distribution techniques is provided. The text material is well illustrated so that those who have never seen a CATV system "in the flesh" can understand what the author is discussing.

"THE ELECTRONIC REVOLUTION" by S. Handel. Published by *Penguin Books Ltd.*, England. Available in the U.S. at paperback book outlets. 248 pages. Soft cover.

This is another "Pelican Original" in the publisher's series of technical texts prepared for the intelligent layman. Like the other volumes in the series, this book is well written, authoritative, and accurate.

The author, who is active in the British electronics industry and a member of the Institution of Electrical Engineers, also gave us the "Dictionary of Electronics" recently.

The text is divided into three main sections: Part One outlines the very beginnings of electronics—from the Ancient Greeks through microelectronics; Part Two describes the electronic revolution in communications, television, computers, automation, transport, war, the life sciences, and entertainment media.

Part Three discusses cybernetics and takes a look at the future.

The author's style is informative and non-stuffy. The text is illustrated with line drawings, sketches, cross-sectional views, and even a cartoon. We venture to guess that even persons working in the electronics field will obtain some new and interesting information from this little book.

"THE CARE AND FEEDING OF POWER GRID TUBES" prepared by Laboratory Staff, *Eimac Div. of Varian*. Available from *Stacey's Scientific Book Center*, 2575 Hanover Ave., Palo Alto, California. 147 pages. Price \$3.95. Soft cover.

This book has been written primarily as a guide to the tube specifier and circuit designer, but radio amateurs and teachers will also find the information of value.

The text covers the types and uses of high-power vacuum tubes from diodes to pentodes and includes special tubes such as zero-bias triodes and super-power tetrodes. In addition, cooling, emission, secondary emission, high-frequency operation, and limiting factors in tube design and operation are discussed. Electron tube materials used in cathodes, grids, filaments, anodes, and envelopes, as well as construction methods, are also explained. The text is illustrated.

"GUIDE TO MOBILE RADIO" by Leo G. Sands. Published by *Chilton Book Company*, Philadelphia. 203 pages. Price \$4.50. Soft cover.

As the author states in his introduction, this book is intended to provide general information to the radio technician interested in servicing mobile radio equipment, the mobile radio equipment sales engineer, and the prospective purchaser or operator of mobile radio systems. He has come close to meeting his goal. Most of the information contained in the text is of the type technicians will need, since it covers equipment.

The text is divided into twelve chapters and eight appendices. The book covers mobile radio, the mobile unit and base station, receivers, transmitters, power supplies, antenna systems, remote control, portable equipment, selective calling, maintenance, licensing, and the field survey. The appendices provide a glossary of mobile radio terms, license eligibility, a list of FCC offices, 10-code abbreviations, phonetic pronunciation of letters, CB radio channels, Business Radio channels, and the 72-76-MHz Band channels. The text is illustrated.

"MOST-OFTEN-NEEDED 1968 TELEVISION SERVICING INFORMATION" compiled by M. N. Beitman. Published by *Supreme Publications*, 1760 Balsam Rd., Highland Park, Ill. 192 pages. Price \$4.00. Soft cover.

This 1968 handbook (Volume TV-27) follows the familiar format used by this publisher in presenting service data for the practicing technician. The information is arranged alphabetically.

TV sets from *Admiral, Airline, General Electric, Magnavox, Montgomery Ward, Motorola, Philco, RCA Victor, Sears, Sony, Sylvania, Westinghouse,* and *Zenith* have been included.

* * *

"THE RADIO AMATEUR'S LICENSE MANUAL" prepared and published by *The American Radio Relay League, Inc.*, Newington, Conn. 85 pages. Price 50 cents. Soft cover.

This is the 58th edition of a popular and authoritative handbook for all persons preparing for ham radio tickets.

The Manual has been extensively updated to include new study questions and answers for the recently reinstated Advanced Class license and revised questions for the Extra Class ticket.

The text includes a complete Rules and Regulations section which reflects all of the recent FCC rules changes. It is a "must" for the Novice, Technician, Conditional, General, Advanced, and Extra classes of license seekers.

*

"RCA SILICON CONTROLLED RECTIFIER EXPERIMENTER'S MANUAL" compiled and published by *RCA Electronic Components and Devices*, Harrison, N.J. 134 pages. Price 95 cents. Soft cover.

This handy manual is designed to be used in conjunction with three experimental SCR kits recently put on the market by RCA. The manual describes 24 circuits which can be constructed to gain experience in working with solid-state circuits. Included are lamp dimmers, motor-speed controls, an electronic timer, a time-delay, electronic flasher, battery chargers, model train and racing car speed control, electronic synchronous switches, light-operated switches, electronic heat controls, overload switches, an a.f.-operated switch, and a heater power control.

The presentation is clear, complete, and well organized. There are line drawings, chassis diagrams, photographs, schematics, and cartoon-like line drawings to aid the constructor. ▲

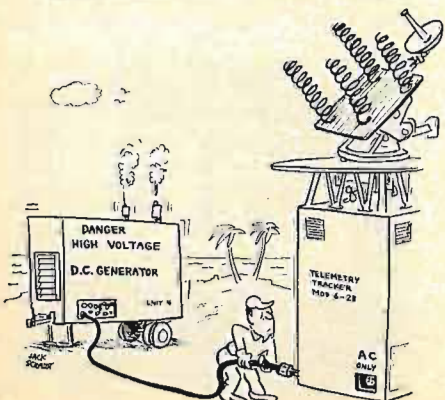

Test this signal transistor at 1mA collector current... and this power transistor at 1Amp collector current... or any collector current you select, from 20 μ A to 1 Amp with the

WT-501A in-circuit/out-of-circuit transistor tester

Battery operated, completely portable, RCA's new WT-501A tests transistors both in-circuit and out-of-circuit, tests both low- and high-power transistors, and has both NPN and PNP sockets to allow convenient transistor matching for complementary symmetry applications. The instrument tests out-of-circuit transistors for dc beta from 1 to 1000, collector-to-base leakage as low as 2 microamperes, and collector-to-emitter leakage from 20 microamperes to 1 ampere.

Collector current is adjustable from 20 microamperes to 1 ampere in four ranges, permitting most transistors to be tested at rated current level.) A complete DC Forward Current Transfer Ratio Curve can be plotted. Three color-coded test leads are provided for in-circuit testing, and for out-of-circuit testing of those transistors that will not fit into the panel socket.

See your Authorized RCA Test Equipment Distributor, or write RCA Electronic Components, Commercial Engineering Department C41-WB, 415 South Fifth Street, Harrison, New Jersey.

Extra features... RCA reliability... for only \$66.75*.

*Optional distributor resale price. Prices may be slightly higher in Alaska, Hawaii, and the West.

RCA



CIRCLE NO. 97 ON READER SERVICE CARD

NEW PRODUCTS & LITERATURE

Additional information on the items covered in this section is available from the manufacturers. Each item is identified by a code number. To obtain further details, fill in coupon on the Reader Service Card.

COMPONENTS • TOOLS • TEST EQUIPMENT • HI-FI • AUDIO • CB • HAM • COMMUNICATIONS

DUAL-OUTPUT POWER SUPPLIES

A new series of laboratory power supplies with two independent d.c. outlets for use in operational amplifier and other dual-output applications, is now on the market.

Designed for series/parallel operation of both

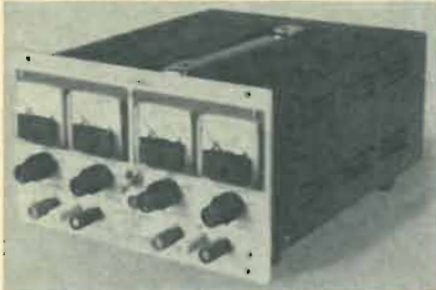

outputs, the supplies can yield two times the voltage or two times the current, up to 500 volts or up to 3.4 amps. Auto series/auto parallel (master-slave) permits tracking to a common reference. Four meters provide simultaneous monitoring of both voltage and current for each output. Crowbar overvoltage protection up to 70 volts d.c. is available as an accessory.

The LPD Series, designed specifically for lab use, features light weight (13 pounds), small size (half-rack, 10 $\frac{3}{8}$ " long), and portability (top-mounted handle). Lambda

Circle No. 126 on Reader Service Card

IC OSCILLATOR/AMP KIT

An inexpensive (\$9.95 list) experimental-type kit designed as an educational tool for engineers and technicians is now available. The kit permits the construction of an IC 500-mW audio power amplifier or variable-tone audio oscillator, providing experience in building equipment designed around an integrated circuit.

The kit, which uses the CA-3020 linear IC, contains all parts and components necessary to complete either of the two pieces of equipment. A non-operating, uncased IC is also provided to permit close examination of its construction under a magnifier.

A companion manual, covering the KD2112 kit, contains basic information on IC's and offers hints on construction. RCA Electronic Components

Circle No. 1 on Reader Service Card

POWER SUPPLIES

A new line of constant-voltage, constant-current power supplies for bench and systems services has been introduced as the HW Series.

There are eight models in the line with outputs ranging from 100 volts d.c. at 2 amperes

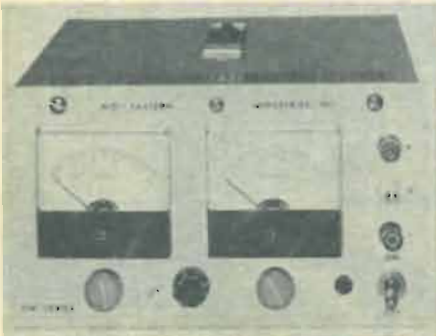

down to 10 volts d.c. at 15 amperes. The r.m.s. ripple in all models is held to 500 μ V. All units feature 0.01% load regulation and 0.005% line regulation.

Units are half-rack width and two may be mounted on a 5 $\frac{1}{4}$ " x 19" panel. Bench models are housed in a sturdy, rubber-footed case with carrying handle.

All units will work in temperatures of up to 50°C with stability of 0.05% under constant load and ambient conditions for 8 hours after a 30-minute warm-up period. Separate meters provide constant monitoring of voltage and current. Mid-Eastern

Circle No. 2 on Reader Service Card

PRECISION POWER RESISTOR

A new housed precision power resistor, capable of extremely low ohmic values, has been added to the firm's RH Series. The new unit permits designers to obtain precision power in a range from 0.008 ohm to 0.099 ohm. It is available in 10-, 25-, and 50-watt models and can be used in voltage regulators, meter shunts, and other circuits which need very low resistances at close tolerances.

The new resistors combine a special winding with the firm's patented heat-sink housing. They exceed MIL ratings for chassis-mounted resistors in both power and dielectric strength. Standard tolerances are from 0.1% to 5%. Standard temperature coefficient is 50 ppm/°C in an operating temperature range from +25 to +275°C. Dale

Circle No. 127 on Reader Service Card

CHARGE-SENSITIVE PREAMP

A new charge-sensitive preamp which can accommodate a variety of detectors—including scintillation, gas proportional, geiger types, and



particularly semiconductor detectors, such as lithium-drifted germanium diodes—without requiring soldered circuit changes, has been introduced as the Model 5554A.

The user can select charge sensitivity, voltage gain, and shaped or non-shaped pulses simply by turning switches. The high-voltage decoupling circuit can be matched to a change in detector by replacing a bias resistor that is held in place by snap-in clips (a resistor kit is included with each instrument to permit matching to a variety of detectors).

Only one voltage, and it can have any value between +20 and +24 volts, is required to operate the preamp. Maximum current drain is less than 80 mA. Companion linear amplifiers, scaler-timers, and multi-channel analyzers can supply this need.

The new preamp weighs only 1.11 pound and measures 3" x 3 $\frac{3}{8}$ " x 8", small enough to allow mounting adjacent to the detector. Hewlett-Packard

Circle No. 128 on Reader Service Card

IC READOUT TUBE DRIVERS

New driver modules for "Nixie" tubes using integrated circuits have been announced. Two series, the BIP-8800 and BIP-9800, are available. All modules accept four-line 8-4-2-1 BCD inputs which are compatible with TTL and DTL. All

units of both series have been designed to exceed applicable sections of MIL-E-5400J and MIL-T-5422E environmental specifications.

The BIP-8800 series units are designed to drive the standard rectangular Nixie tubes (0.6" character height). They are available with or without memory (in the same compact package) and can drive either a "0-9" or a "0-9 with decimal point" tube.

The BIP-9800 series modules are designed to drive the miniature rectangular Nixies with 0.3" character height. The BIP-9801 driver is available in a housing measuring only 1.87" deep x 0.480" wide x 0.960" high. A decoder/driver with memory is under development.

Complete pricing, technical information, and cost comparisons will be supplied on request. Burroughs

Circle No. 129 on Reader Service Card

DARLINGTON TRANSISTORS

An expansion of the power integrated Darlington transistor series to include three packages, TO-5, TO-18, and TO-47, has been announced.

The TO-5 package is capable of dissipating 1.3 watts at 25°C and is identified as the SDM 1010-1019 series. The TA-18 package is capable of dissipating 1 watt at 25°C and is identified as the SDM 1110-1119 series, while the TO-47 package with the same dissipation is designated SDM 1210-1219 series.

The devices are guaranteed to have a minimum cut-off frequency of 50 MHz. Saturation voltage is 1 volt at an I_C of 100 mA and I_B of 0.2 mA. I_{CBO} leakages are specified to be 50 mA maximum, current rating is 0.5 A, and the maximum junction temperature is 125°C.

Full electrical specifications on this new series are available. Solitron.

Circle No. 130 on Reader Service Card

COLOR-ALIGNMENT GENERATOR

A lightweight, solid-state TV alignment generator capable of generating the familiar 10-bar gated rainbow plus all new single-bar and three-bar test patterns is being marketed as the Model 865 "Deluxe Color Commander".

The new instrument provides nine patterns, thus reducing the time a technician must spend on the job making adjustments. The generator combines extensive convergence and centering display capability with a variety of popular color-bar patterns. Since the patterns are crystal-controlled, the Model 865 is nearly impervious to temperature variations.

The unit measures 4 $\frac{7}{8}$ " x 9 $\frac{1}{2}$ " x 5 $\frac{1}{4}$ " and weighs less than four pounds. It is powered by its own built-in a.c.-d.c. power supply which permits either 117-volt a.c. or battery operation.



The generator is housed in a luggage-type case, with handle, that has plenty of storage space for probes, tubes, etc. Amphenol Distributor Div.
Circle No. 3 on Reader Service Card

SOLID-STATE SWEEP GENERATOR

The Model VS-30 solid-state sweep generator has recently been added to the firm's expanding line of such instruments. The new unit is designed as a laboratory and production instrument covering the frequency range of 300 kHz to 100 MHz. The sweep width is continuously

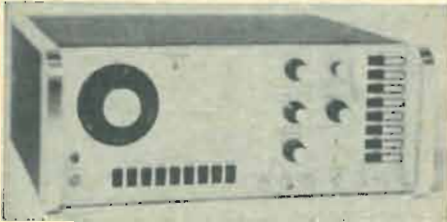

adjustable from 200 kHz to 100 MHz. The r.f. output is extremely flat and is specified for a flatness of ± 0.25 dB at maximum sweep width with 1-volt r.m.s. into 50 ohms, according to the company.

The unit has provisions for eight plug-in crystal-controlled markers, a variable marker option, sweep rate controls from 5 to 60 Hz, plus manual sweep.

A data sheet with complete electrical specifications will be provided on request. Texscan
Circle No. 131 on Reader Service Card

GARAGE-DOOR OPENER

The new "Liftmaster" garage door opener is a complete electronic system consisting of a transmitter, wall-mounted radio receiver, and a ceiling-mounted operating mechanism.

The portable "Signal-Sender" is a small radio transmitter about the size of a pack of cigarettes. It is completely self-contained in a high-impact

plastic case and comes supplied with a 9-volt transistor radio battery. The crystal-controlled r.f. design incorporates four transistors and requires no field adjustment. It transmits a pulse-tone modulated command to the receiver. It measures $2\frac{3}{4}$ " and $3\frac{3}{4}$ " x 1" and is equipped with snap-on bracket and auto sun visor clip.

The wall-mounted receiver is easily accessible for code changing or servicing. It has an integral push-button for electric (non-radio) operation. It has a crystal-controlled superhet circuit and a pulse-tone detector which discriminates against unauthorized signals. The receiver uses 11 transistors and two diodes and is powered from the operating mechanism's low-voltage circuit.

The operating mechanism has a $\frac{1}{4}$ -hp, 117-volt, capacitor-start motor which moves the door at a speed of up to 10 inches per second. Perma-Power

Circle No. 4 on Reader Service Card

LINEAR IC SAMPLER KIT

A new sampler kit containing 26 linear integrated circuits for use in a wide variety of consumer, commercial, and industrial equipment applications is now being offered at moderate cost.

In one package, this comprehensive sampler provides the equipment engineer with significant types from a broad line of linear IC's and complete technical data and application information on each type.

Eleven separate linear IC types are supplied, with two or three of each type provided. Additional information about the kit and the IC's included will be forwarded on request. RCA Electronic Components

Circle No. 132 on Reader Service Card

CERAMIC CAPACITORS

A new product line of Kemet precision-molded ceramic capacitors is now available. Housed in rugged, moisture-resistant epoxy cases and made to meet the requirements of MIL-C-11015C, the

new units are available in four radial and eight axial lead configurations.

The capacitors are suited for bypass, filtering, and coupling in low-voltage and solid-state circuits for computers, industrial controls, ordnance devices, instruments, and military electronics equipment. Capacitance range is 10 pF to 2 μ F in working voltages of 50, 100, and 200 volts. Temperature operating range is -55° to $+125^{\circ}$ C. Union Carbide

Circle No. 133 on Reader Service Card

STATIC METER

A lightweight, low-cost static meter for measuring electrostatic potentials is on the market as the "Statimeter". It measures both positive and negative potentials and indicates the polarity as well as the charge on the meter face.

The radium sulphate source in the static detection head has a long half-life and contains less radioactive material than a luminous watch dial.

Literature on the "Statimeter" is available. Controlled Environment

Circle No. 134 on Reader Service Card

DIGITAL VOLTMETER

A new half-rack, automatic digital multimeter that requires no zero or other calibration controls to hold a d.c. accuracy of 0.01% ± 1 digit



**A NEW DIMENSION IN HI-FI
 SOUND PERFORMANCE
 FROM KENWOOD**
 ... PENETRATING THE
 OUTER LIMITS OF
 SOUND REPRODUCTION

**165 watt 3 CHANNEL
 STEREO AMPLIFIER with ELECTRONIC CROSSOVER
 NETWORK**



KENWOOD SUPREME I

FEATURING:

the finest sound reproduction by driving the woofer, mid-range and tweeter speakers separately through a multi-channel amplifier.
 Priced at \$695. Write for particulars.

the sound approach to quality



3700 South Broadway Place, Los Angeles, Calif. 90007
 69-41 Calamus Avenue, Woodside, New York 11377

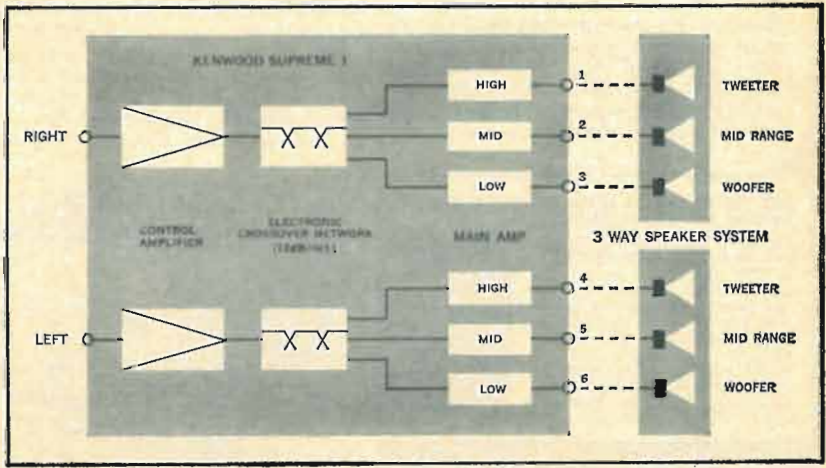

CIRCLE NO. 106 ON READER SERVICE CARD

Ziff-Davis Service Division, Dept. ISH
595 Broadway, New York, N. Y. 10012

Please send my copy of the 1968 ELECTRONICS
INSTALLATION & SERVICING HANDBOOK
as checked below:

- I am enclosing \$1.25 plus 15c for shipping
and handling for the Regular Edition.
(\$1.75 for orders outside U.S.A.)
- I am enclosing \$3.00. Please send me, postpaid
the Leatherflex-covered Deluxe Edition,
(\$3.75 for orders outside U.S.A.)
(Please allow 3 additional weeks for delivery
of the Deluxe Edition.)

print name _____

address _____

LW-48

city _____

state _____

zip code _____

**HERE'S
THE MOST IMPORTANT
JOB TICKET YOU'LL
WRITE UP THIS YEAR!**



**NOW—GET THE TRICKS OF THE TRADE FOR
SERVICING EVERYTHING . . . FROM TV TO
AM/FM . . . FROM CITIZEN'S BAND TO PUBLIC
ADDRESS . . . FROM HOME INTERCOM
TO TAPE CARTRIDGE UNITS. THEY'RE ALL
IN THE NEW, 1968 ELECTRONICS INSTALLA-
TION AND SERVICING HANDBOOK.**

You'll find the latest, most compre-
hensive technique advice, equipment
information and step-by-step "how-to-
do-it" hints that will aid you in your
servicing (or save you costly outside
repairs).

This 140-page "encyclopedia" of elec-
tronics servicing knowledge contains a
special, full-color section on color TV
maintenance . . . model numbers and
prices of replacement parts . . . recom-
mended tools for every operation . . .
accessory information to help you turn
an extra dollar. Plus up-to-the-minute
reports from hundreds of manufac-
turers.

Whether you're a professional service-
man, weekend home hobbyist or spare
time "Mr. Fixit," the 1968 ELECTRON-
ICS INSTALLATION AND SERVICING
HANDBOOK is essential for you. Essen-
tial for your profit, fun or both.

**GET THE HANDSOME LEATHERFLEX COVERED
EDITION FOR \$3 POSTPAID!**

The 1968 ELECTRONICS INSTAL-
LATION & SERVICING HANDBOOK
is also available in a splendid
deluxe edition. Rugged Leather-
flex cover provides lasting protec-
tion yet is softly textured and
gold-embossed for the look of
elegance. A collector's item — a
superb addition to your electron-
ics library. And it's yours, for just
\$3 postpaid, when you check the
appropriate box on the order form.



ORDER YOUR COPY TODAY!

for 90 days is now available as the Model DM
440.

Automatic ranging with 20% overrange, in-
stantaneous push-button switching for mode and
range changing are standard. Common mode
rejection of 140 dB at 60 Hz with up to 1000-
ohm source imbalance in either lead is retained
even when the digital output is connected to a
grounded data system.

Although the basic instrument is flexible and
versatile, according to its maker, field expansion
is made possible through a combination of plug-
in accessories such as d.c. mV measurement, d.c.
volts, a.c. volts, kilohms, and d.c. ratio. Darcy
Industries

Circle No. 135 on Reader Service Card

COMPACT ULTRASONIC CLEANER

A compact ultrasonic cleaner which is small
enough and inexpensive enough for most small
labs and workshops is now available as the
Model LP-2.

The unit is housed in an all-metal and stain-
less steel cabinet which measures 6" x 4" x 4".



The cleaning liquid is cavitated in a crystal beaker
which can be filled, emptied, and objects rinsed
without moving the basic cabinet. The cleaning
liquid is cavitated at a frequency of 90 kHz,
nominal. Electromation Components

Circle No. 136 on Reader Service Card

RECTANGULAR TRIMMER

A new, infinite-resolution rectangular trimmer
that features a metal glaze resistance element is
now on the market as the Type 650.

The new trimmer is available with Teflon-
insulated leads or offset PC pins. A bushing-
mounted model is also available. All models are
housed in moisture sealed, high-temperature di-
allyl phthalate cases that insure protection from
severe environments. They exceed the environ-
mental and life requirements of MIL-R-22097C.

The units are rated ¾ watt at 85°C and are
available over a resistance range of 100 to 10,000
ohms, ±5%. IRC

Circle No. 137 on Reader Service Card

WAVEFORM GENERATOR

The Model F250A waveform generator covers
the frequency range from 0.0005 Hz to 3 MHz.
Sine, square, triangle, and ramp outputs are
available and amplitude output is continuously
variable from 0 to 32.5 volts peak-to-peak with
50 or 600 ohms output impedance.

External voltage control of frequency allows



the unit to operate as a v.c.o., frequency shift
keyer, or FM modulator. Other features in-
clude trigger, tone burst, sweep, and phase-lock
capabilities.

Optional accessories include portable power
sources, attenuators, power amplifiers, and tone-
burst control units. Data Royal

Circle No. 138 on Reader Service Card

HI-FI—AUDIO PRODUCTS

FOUR-WAY SPEAKER SYSTEM

A new 4-way speaker system which includes
a full 15-inch woofer yet is housed in an en-
closure measuring just 28" x 19" x 13" has
been introduced as the Model CS-63.

In addition to the 15-inch woofer, the system
uses a 6½-inch cone-type midrange unit, a
horn-type tweeter, and a 2½-inch cone-type
super tweeter. Crossovers are at 600, 4000, and
13,000 Hz. Frequency response is from 25 to
20,000 Hz and power handling capacity is 60
watts. Input impedance is 8 ohms.

There are two tone controls on the rear of
the unit: one provides for flat increase or de-
crease of the middle frequencies while the sec-
ond control provides for boost or cut of the
high frequencies. Tonal response can thus be
varied to suit individual taste or the acoustic
environment.

The oiled-walnut enclosure is designed to be
used either on a bookshelf or as a free-standing
floor unit. The grille cloth is removable and
can be changed to match any particular decor.
Pioneer

Circle No. 5 on Reader Service Card

AUTOMATIC TURNTABLE

The new PE 2020 automatic turntable fea-
tures an exclusive control in its cartridge which
permits the proper 15° vertical tracking angle
to be set for each record.

Other features of this new unit include an
automatic anti-skating device combined with an
exact adjustment dial to compensate for stylus



shape and friction; a cartridge shell that accepts
all cartridges with an exact slide-fit mounting;
a single-lever command center which controls
start, stop, repeat, cueing, and lift; automatic
start and shut-off in either single play or with
a stack of records; and an exclusive automatic
scanning device which measures the diameter of
any record and adjusts the tonearm accordingly.

The turntable is powered by a four-pole,
four-coil induction motor and operates at four
speeds. A revolving spindle on single play re-
duces center-hole wear. Low record drop in
automatic operation helps prolong record life.
Elpa Marketing

Circle No. 6 on Reader Service Card

100-WATT STEREO RECEIVER

The Model MD 2000 is a solid-state AM-FM
stereo receiver which provides 100 watts of
IHF dynamic power. The all-silicon amplifier
has a frequency coverage from 15 to 40,000
Hz and a 20-40,000 Hz power bandwidth. The
power transistors are protected from overloads
and short circuits by the firm's double-pro-
tection "protector circuit", which operates in
microseconds.

The receiver has four sets of output speaker
terminals to drive two sets of stereo speakers
and a front-panel speaker selector switch. It
also features a stereo indicator light, illumi-

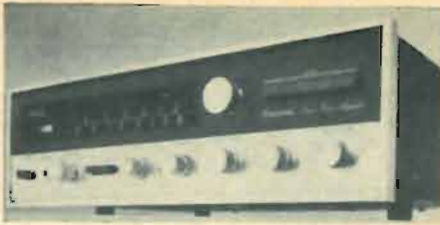

nated AM-FM tuning meter, interstation muting circuit, front-panel stereo phone jack, a friction-coupled tone control, direct tape monitor, high- and low-cut filters, mode and selector switches, flywheel tuning, and an FM SCA filter. The input antenna terminals are designed to handle either 75- or 300-ohm antennas.

The receiver is housed in a functional brushed silver-gold case with a black tuning dial face. It measures 16 1/2" w. x 4 15/16" h. x 13 1/4" deep, excluding knobs. Sansui

Circle No. 7 on Reader Service Card

UNRECORDED CASSETTES

A new line of compact cassettes which will fit all presently available transports has been introduced for those who wish to make their own recordings.

The cassettes are available in two sizes: the RC-60 which provides 60 minutes recording time and the RC-90 which records for 90 minutes when run in both directions. The cassettes are color-coded and are sold in a self-mailer package for the convenience of those corresponding by tape. Reeves Soundcraft

Circle No. 8 on Reader Service Card

PORTABLE CASSETTE RECORDER

Model RK-85 is a fully transistorized, battery-operated portable recorder which features separate push-button controls for fast forward, rewind, stop, play, and safety record. "The Transcorder" uses a tape cartridge and will record or

play back 120 minutes of program material. It has a combination recording level and battery strength meter, earphone jack, auxiliary input jack for recording from external sources, and a built-in 2 3/4" dynamic speaker. It operates on 5 "C" cells or 117-volt a.c., with optional a.c. adapter.

The recorder measures 8 3/4" x 5" x 2 1/4" and comes complete with remote-control microphone and stand, earphone, batteries, hand strap, and blank cassette tape. Lafayette

Circle No. 9 on Reader Service Card

SPEAKER FOR MUSICAL COMBOS

A voice speaker, specifically designed for the electronic musician, has just been put on the market as the Model CJ-125 "Banshee". Boasting a peak music power of 125 watts, the speaker is for use as an auxiliary unit to handle the vocals of music groups and make possible a sound level equal to or greater than that which is generated by their instrument amplifiers.

The speaker is for use on a speaker stand, two models of which are available from the company. The speaker is a cobra-flare horn, fabricated of unbreakable fiberglass in jet black with red re-entrant assembly. The speaker measures 23" wide x 13" high x 19" deep and weighs 20 pounds. Response is 100-12,000 Hz and sound intensity is 131 dB plus. Impedance is 16 ohms. Form PP-2535 containing complete details on this speaker will be forwarded on request. Atlas Sound

Circle No. 10 on Reader Service Card

PLAYBACK-ONLY TAPE DECK

The Sony TC-155 is a playback-only, solid-state, four-track stereo tape deck designed for those who own a stereo tape recorder and want to add a tape duplicating system or those without a stereo recorder who only want to play prerecorded tapes, not make recordings.

With self-contained solid-state preamps for the playback of four-track prerecorded stereo tapes,



the TC-155 operates at 7 1/2, 3 3/4, and 1 7/8 in./s. It also has a retractomatic pinch roller for threading ease as well as a stereo headphone jack. It also features a new vibration-free motor and a scrape flutter filter which is a special idler that eliminates tape modulation distortion. Superscope

Circle No. 11 on Reader Service Card

NEW AUDIO TAPE LINE

Two new series have just been added to the firm's line of consumer audio tapes. The low-noise 304 Series offers minimal background noise and improved high-frequency response at standard and slow recording speeds. It features a high-quality oxide binder similar to that used in the company's professional low-noise tapes. Best performance is achieved with sophisticated home recording units, especially those which permit bias adjustment.

The 301 Series is a multi-purpose tape for recording at all popular speeds. It is said to provide excellent performance in voice recordings at slow speed, background music at intermediate speed, and hi-fi music at standard speed.

Both series are available in acetate and polyester base materials and in 7" and 5" reels. In

BEST YEAR YET TO SELL THE BEST



3 ZENITH WAVEMAGNET® INDOOR TV ANTENNAS built to the quality standards of Zenith original parts



DELUXE
ALL-CHANNEL
Part No. 973-56

Two full-size UHF
loops develop high
front-to-back ratios
equal to many
outdoor antennas.



VHF ONLY
Part No. 973-58



ECONOMY
ALL-CHANNEL
Part No. 973-55

Zenith has designed these Wavemagnet antennas for sensitive reception in color or B/W. Fully adjustable telescopic dipoles. Six-position selector switch for top performance on each channel. Handsome molded base of high-impact styrene. Individually packaged for effective sales display. Order now from your Zenith distributor.

ZENITH®

The quality goes in
before the name goes on

CIRCLE NO. 87 ON READER SERVICE CARD

When There Are Thousands of Candidates



Be Sure You Select The Ones That Suit You Best

This year, play it smart.

Before you cast your vote—and spend your hard-earned cash on any kind of photographic equipment—make sure you're getting the most for your money!

Shop before you buy, with the all-new, easier-to-read 1968 PHOTOGRAPHY DIRECTORY & BUYING GUIDE.

All the guesswork is out! From still cameras to slide projectors, super-8 to video tape recorders . . . this encyclopedic volume puts every essential buying fact and figure right at your fingertips. With complete point-by-point information on manufacturer, model number, special characteristics and price. Hundreds of photos. Every vital statistic you need to compare all the latest equipment—in virtually every category—and select the best in your price range!

Over 3,000 photographic items in all! Plus extra large photos of every type of product listed. And a special feature called "BUYPOINTS"—an exclusive "what-to-look-for, how-to-buy" guide to movie and still cameras, slide projectors, tapé recorders.

This 180-page "shop at home" directory has been carefully compiled by the editors of Popular Photography. And that means authoritative precise information you can bank on . . . all year long! It is available only through this advertisement, or on newsstands. Be sure to order or buy your copy today!

USE THE COUPON BELOW TO ORDER YOUR COPY DIRECT FROM THE PUBLISHER—only \$1.25

GET THE HANDSOME LEATHERFLEX-BOUND EDITION for just \$3 POSTPAID!

The 1968 PHOTOGRAPHY DIRECTORY & BUYING GUIDE is also available in a splendid deluxe edition. Rugged Leatherflex cover provides lasting protection yet is softly textured, and gold-embossed for the look of elegance. A collector's item—a superb addition to your permanent reference library. And it's yours, for just \$3 postpaid, when you check the appropriate box on the order form.

ZIFF-DAVIS SERVICE DIVISION • DEPT. PD
595 Broadway • New York, N.Y. 10012

Please send me a copy of the 1968 PHOTOGRAPHY DIRECTORY & BUYING GUIDE as checked below:

\$1.25 enclosed, plus 15c for shipping and handling. Send me the regular edition, (\$1.75 for orders outside the U.S.A.)

\$3.00 enclosed. Send me the Deluxe Leatherflex-bound edition, postpaid. (\$3.75 for orders outside the U.S.A.) Allow three additional weeks for delivery.

name _____

PLEASE PRINT

address _____

city _____

EW-48

state _____

zip code _____

PAYMENT MUST BE ENCLOSED WITH ORDER

addition, the 301 Series is available on 3" reels and a newly introduced 3" x 4½" plastic mailer. Ampex

Circle No. 12 on Reader Service Card

STEREO TAPE DECK

A new stereo tape deck that features a high-torque synchronous motor, four tracks, three speeds, and automatic shut-off, has just been introduced as the Model 302-D.

It features two large, easy-to-read record level meters; a 4-digit index counter; reset button; separate record buttons; sound-with-sound cap-

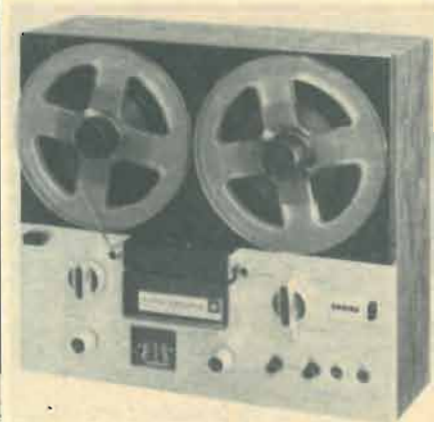

ability; fast forward and rewind; a pause/cue control; two line and two microphone inputs; two line outputs; captive a.c. cord; and three mechanically switched speeds, 7½, 3¾, and 1⅞ in/s. Concertone

Circle No. 13 on Reader Service Card

CASSETTE SOUND SYSTEM FOR CARS

The "Car-Mount" cassette tape sound system for cars has just been introduced. The unit consists of a sliding tray which holds a "Carry-Corder", a miniature cordless tape recorder using compact cassettes with up to 90 minutes of playing/recording time. The "Car-Mount" is powered by the car's ignition system, thus eliminating drain on the recorder's batteries. It also has a built-in regulator to assure proper voltage to the "Carry-Corder" under varying driving conditions as well as a modulation control providing peak output with all types of AM or AM-FM car radios.

Although the "Carry-Corder" can be removed easily for use as a portable, the new "Car-Mount" provides a special locking apparatus for protection against theft. Norelco

Circle No. 14 on Reader Service Card

REEL-TO-REEL TAPE DECK

A new stereo tape deck, the Model 510-D, is a reel-to-reel unit designed for use with any hi-fi system. A major feature of this 3-speed deck is automatic sound-on-sound recording. The sound-on-sound electronic switch control and input jacks for the microphone are both located on the front panel. The specially designed tape transport mechanism uses a four-pole laminated stator drive motor with symmetrical Oilite thrust bearings.



The deck is equipped with two professional-quality solid-state preamps; push-button tape counter; calibrated record-level meters, a cue and edit control; and vertical or horizontal operation. Reel capacity is up to 7".

Frequency response at 7½ in/s is 30-18,000 Hz ±3 dB; wow and flutter is less than 0.17%. The deck measures 13¾" w. x 11⅞" h. x 5½" d. It weighs 19½ pounds. Concord.

Circle No. 15 on Reader Service Card

CB-HAM-COMMUNICATIONS

SOLID-STATE CB UNIT

The Model HE-20T is an FCC-type-accepted, solid-state CB radio with 12 crystal-controlled transmit channels and 23 tunable receive channels. The circuit uses 13 transistors and 10 diodes to produce the full 5-watt transmitter input power. An efficient push-pull audio modulator provides greater talk power, according to the company.

The tunable superhet receiver features a 455-kHz mechanical filter, variable squelch, and automatic series gate noise limiter. The unit has an "S" relative r.f. output meter, spotting switch, pi-network antenna match, earphone jack, p.a. provision, and a socket for connecting the firm's selective call unit.

The Model HE-20T has built-in 117 volt a.c. and 12-volt d.c. positive- or negative-ground



power supplies. It comes with a fused d.c. line cord, a dynamic microphone with coiled cord, a set of crystals for channel 9, and an adjustable mobile mounting bracket. The unit measures 12¼" x 5" x 7½". Lafayette

Circle No. 16 on Reader Service Card

RADAR WARNING DEVICE

A miniature microwave receiver which clips to the car's sun visor and alerts the driver to the fact that he is approaching a radar speed zone has been put on the market as the "Radar Detector".

The unit weighs 12 ounces, is completely transistorized, and operates on two penlight batteries. It has a range of up to two miles. The device picks up radar signals from the police vehicle and emits a steady beep to remind the driver to slow down to posted limits.

The detector has no radiation of its own and will not interfere with any transmission. It is completely noiseless when not picking up a transmitted radar signal. The unit is legal in all states except Virginia and Massachusetts, according to the manufacturer.

A data sheet giving full details on the device is available on request. Mutronics Products

Circle No. 17 on Reader Service Card

23-CHANNEL SOLID-STATE CB

The Model 777 CB transceiver uses frequency synthesizing circuitry to provide full 23-channel operation. The unit is packaged in a rugged 6½" x 2" x 10" low-profile case and can be dash mounted for vehicular communications or placed on an optional pedestal-mount power supply for use as a base station.

An illuminated and magnified channel selector switch permits simultaneous dialing of any single transmit and receive channel selected. Both transmitter and receiver are always locked on frequency. A sensitive S-meter indicates relative signal strengths of incoming received signals and doubles as a power indicator on transmit. Volume, "on-off", and adjustable squelch are combined in a single, front-panel control, while primary TR switching is accomplished by



means of a push-to-talk button on the microphone.

The solid-state transmitter delivers a minimum of 3 watts of r.f. power to the antenna. Input is the full 5 watts permitted by the FCC. Modulation percentage is a minimum of 85%, with 100% maximum. The transmitter can be coupled to any 52-ohm CB antenna—base station or mobile. Amphenol

Circle No. 18 on Reader Service Card

23-CHANNEL TRANSCEIVER

The new "23-Plus", 23-channel CB transceiver features a new cascode front-end and nuvisor mixer, 23 crystal-controlled channels, a modulation sampler to improve audio level, transistorized power supply, an illuminated "S" meter, illuminated channel selector, single-knob tuning, and a built-in range-expander circuit.

The unit comes with crystals for all 23 channels, mounting brackets, power cords, and microphone. Courier

Circle No. 19 on Reader Service Card

PLANAR SPIRAL ANTENNAS

Two new planar spiral antennas which meet the electrical and mechanical requirements of military ELINT systems are now available. The Model R35-1 offers octave coverage at the S-band while the Model R33-1 operates through the 2-10 GHz range.

The 3-dB beamwidth uniformity is $\pm 8^\circ$ for the S-band antenna regardless of frequency, polarization, or pattern cut, with an average value of 70° . For the R33-1, the corresponding figures are $90^\circ \pm 12^\circ$ (2-3 GHz) and $78^\circ \pm 12^\circ$ (3-10 GHz).

Minimum squint is less than 5° , axial ratio is less than 1.5 dB, and gain tracking in matched pairs is ± 0.5 dB. Data sheets on the new antennas will be supplied on request. Dorne and Margolin

Circle No. 139 on Reader Service Card

MANUFACTURERS' LITERATURE

FILTER DESIGN DATA

Information on the circuit design of low-, high-, and band-pass filters is contained in a new 12-page booklet now available. Using the instructions and data in the booklet, circuit designers can more rapidly design filters which best meet their requirements.

The booklet contains data, charts, and examples to simplify the text material. Nytronics

Circle No. 140 on Reader Service Card

COLUMN SPEAKER DATA

Three data sheets which provide information on three models of hi-fi column speakers are available as Nos. 146, 147, and 148.

All three sound columns have 100 watt power capability and differ only in frequency response, the number and type of speakers used, coverage angles, and sensitivity. Jensen

Circle No. 20 on Reader Service Card

MATV DESIGN BOOKLET

A 24-page booklet showing how to design master TV antenna systems is now available. Covering systems for homes, dealer showrooms, apartment houses, hotels and motels, hospitals, and schools, the design booklet features techniques not previously used in MATV system

design, such as cable-powered, remotely located amplifiers and a new method of on-channel u.h.f. distribution.

The booklet includes fourteen representative system diagrams, showing bills of materials and typical costs. It also includes information on how to estimate costs and prepare bids, how to sell MATV systems, and how to install and service the systems. JFD Electronics

Circle No. 23 on Reader Service Card

MAGNETIC REED SWITCHES

Detailed specifications on a full line of magnetic reed switches are given in a new 6-page, 3-color catalogue. Red, white, and blue color coding of standard coil power requirements to switch types and ampere-turn ranges, a special catalogue feature, assists in the selection of the best switch for the job.

Fundamental considerations for switch selection and application are also outlined, and special treatment is given to the effects of cutting and bending switch leads on the ampere-turns characteristics of the switch. Gordos

Circle No. 141 on Reader Service Card

KNOB CATALOGUE

Over 350 standard, off-the-shelf instrument and control knobs are described in a new 24-page catalogue, No. 111.

The publication contains thermosetting plastic and metal knobs in a variety of sizes ($\frac{1}{2}$ " to 3" dia.), designs, colors, and functions. A selection guide and all dimensions are included. Kurzkasch

Circle No. 142 on Reader Service Card

NEON-GLOW LAMPS

An 8-page illustrated brochure has just been published, describing neon-glow lamps for indicator applications, circuit components, and voltage regulators.

A complete description on evaluating and applying neon-glow lamps including discussions



STEREO/HI-FI DIRECTORY

Giant 180 page buyers guide to virtually every new audio component on the market — amplifiers • changers and turn tables • receivers • tuners • tape machines • speakers, etc.

1968 #56

1967 #45

TAPE RECORDER ANNUAL

The only buyers guide of its kind available to the brands and models on the market. Over 132 pages of full information on over 250 models plus articles covering every aspect of tape recording.

1968 #59

1967 #42

Ziff-Davis Service Division—Dept. W • 595 B'way, New York, N.Y. 10012

I am enclosing \$_____ for the annuals circled below. My remittance includes an additional 15¢ per copy for shipping and handling (50¢ for orders outside U.S.A.). I understand quantities are limited and orders will be filled on a first come-first served basis.

\$1.25 each

42 45 56 59

Print Name _____

EW-48

Address _____

City _____

State _____

Zip _____

PAYMENT MUST BE ENCLOSED WITH ORDER

NEW COAX MATCHING TRANSFORMER

for Color TV



One transformer for indoor or outdoor use. The Mosley MATR-37 provides a perfect match of 300/75, 75/300 ohm connections. Easily attached to antenna (close to the signal source) or directly to receiver terminals. Solderless. Easy to install.

Write Dept 160 for FREE detailed brochure.

Mosley Electronics, Inc. 4610 N. Lindbergh Blvd.,
Bridgeton Missouri 63042

CIRCLE NO. 103 ON READER SERVICE CARD

REGULATED POWER FOR SENSITIVE EQUIPMENT



INVERTERS DC to Quality AC FREQUENCY CHANGERS Inferior AC to Quality AC

For mobile and emergency operation of electronic instruments, video tape recorders or other sensitive equipment. Field-proven and available from stock.

- Output: 115 V \pm 5%; 60 \pm .03 sine wave, maximum 6% harmonic distortion
- Input: Inverters—11-15 or 22-30 VDC
Changers—95-125 VAC, 50-500 cps
- 1000, 500, 250 and 125 VA models
- All-transistorized for high reliability, low acoustic noise and instant turn-on
- Used by Industry and Military

SEND FOR COMPLETE CATALOG

TOPAZ INC.

ELECTRONICS MAGNETICS

3802 HOUSTON ST., SAN DIEGO, CALIFORNIA • 92110 (714) 297-4815

CIRCLE NO. 83 ON READER SERVICE CARD

WAVE FORM ANALYSIS & PEAK FM MODULATION



all for LESS MONEY!

The Lampkin 205A FM Modulation Meter accurately indicates PEAK modulation on mobile transmitters. To shoot trouble visually, use your own general-purpose oscilloscope at the 205A rear jack output. This makes a low-cost, highly effective test combo — and a well-rounded shop — all for less money.

Lampkin pioneered the PEAK voltmeter for FM modulation indication.

Like to see the complete specs? Mail coupon today!

Use this coupon for FREE booklet "How To Make Money in Mobile-Radio Maintenance" and information on Lampkin meters.

Name _____
Address _____
City _____ State _____ Zip _____

LAMPKIN LABORATORIES, INC.
MFM Div., Bradenton, Fla. 33505

CIRCLE NO. 105 ON READER SERVICE CARD

on light output, longevity of the lamp, and external conditions acting on the glow lamp are presented. The brochure includes an ionization time vs percent overvoltage graph, plus a circuit showing various breakdown measurements, as well as a compilation of relevant terms, which are clearly defined.

Catalogue information is included on the company's complete line of glow lamps. Signalite
Circle No. 143 on Reader Service Card

H.F. ANTENNA SYSTEMS

A catalogue which includes data on a line of high-frequency antennas for radar, direction finding, communications, radio propagation research, and electronic warfare is now available.

The catalogue discusses in detail a broad range of specialized h.f. antenna systems for extremely high power and producing both horizontal and vertical beam steering by phase array techniques. The antennas are being used in various military systems including long-range h.f. direction finding, h.f. communications—antennas and receivers, and specialized jamming antennas for airborne, fixed wing, and helicopter implementation, as well as ground-base jamming countermeasures. Keltec Industries

Circle No. 144 on Reader Service Card

TV CIRCUIT BREAKER GUIDE

A complete line of circuit breakers for the television industry is now listed in a vest-pocket cross-reference guide, #X53.

The replacement model numbers are listed for the various television receiver manufacturers' part numbers for easy selection. Workman

Circle No. 24 on Reader Service Card

ENGINEERING DATA ON MOTORS

A completely revised, 80-page publication entitled "Technical Information for the Engineer No. 1—Tenth Edition" has been issued.

The handbook includes new definitive and authoritative information about servo motors, inertial damped motors, synchronous motors, stepper motors, motor tach generators, synchros, resolvers, servo electronics, and servos. There are more than 200 illustrations including block diagrams, curves, charts, graphs, tables, circuit drawings, and wiring schematics.

Three-hundred mathematical equations, formulas, and expressions amplifying the topics discussed are also included, along with a comprehensive servomechanism conversion-factor tabulation. Kearfott

Circle No. 145 on Reader Service Card

SWITCH/RELAY DESIGN DATA

A new 12-page catalogue called "Design Ideas for Engineers" is now available. The publication features an expanded section on miniature electronic switches, miniature remote-control relays, miniature readout indicators and pilot lights, miniature ceramic terminal strips, and machined aluminum knobs.

Of special interest to engineers is the "pull-to-unlock" lever switches designed to safeguard against accidents, 3- and 4-pole miniature push-button switches, miniature motor-start power switches, 12-position adjustable-stop miniature rotary switches, and an isolation relay for industrial remote-control applications. Alco

Circle No. 146 on Reader Service Card

LEVEL-CONTROL DATA SHEETS

Five, one-page data sheets covering level controls for speaker loads from 5 watts to 75 watts, are now available. Each data sheet pictures the unit, provides a general description, application notes, installation data, and circuit connections, plus wiring diagram, mechanical specifications, and a performance graph.

The sheets are punched for insertion in a 3-ring binder. Jensen

Circle No. 25 on Reader Service Card

CONTROL KNOBS

A 12-page catalogue covering a comprehensive line of control knobs for electronic equipment and appliances is now available.

Each knob in the line is pictured, described, and complete dimensional data listed. In addition to the standard stock knobs shown in the catalogue, the company is prepared to make special knobs to the customer's specifications. Rogan Bros.

Circle No. 147 on Reader Service Card

SOLID-STATE P.A. AMPLIFIERS

A catalogue which details the firm's complete line of "Challenger CHS" solid-state public-address amplifiers is now ready for distribution. In succinct terms by means of charts and photographs, the catalogue describes the Models CHS-100, CHS50, CHS35, and CHS20, listing all technical data and prices. One page is devoted to a listing of accessories.

Copies of catalogue No. 326 will be forwarded on request. Bogen

Circle No. 26 on Reader Service Card

SERVICE TEST INSTRUMENTS

Revised catalogue AAD-38 which contains information on a complete line of service test instruments is now available for distribution.

The publication describes and illustrates clamp-on v.o.m.'s, line probes, voltage testers, and kits for test equipment and related accessories. Amprobe

Circle No. 27 on Reader Service Card

SELENIUM SURGE SUPPRESSORS

A new slide-rule-type selector which permits the quick and easy selection of the correct surge suppressor for any application and a companion brochure with easy-to-use information on circuit design, operation, ratings, construction, and applications of the units are now available.

The slide selector is simple to use. With the slider set on the appropriate transformer kVA, the rule matches the transformer secondary line-to-line voltage against the corresponding surge suppressor selenium cell symbol. The cell symbol is the key to a table provided on the slide selector which gives the maximum discharge current rating for that application. Both single- and three-phase applications are covered by the selector. Westinghouse

Circle No. 148 on Reader Service Card

MUSIC SYSTEM BROCHURE

Special features and performance specifications on the Model SC-2520 music system are contained in a four-page data sheet, LIT-905.

The system plays records, receives FM mono and stereo broadcasts, and records and plays tapes by means of a built-in cassette system. Harman-Kardon

Circle No. 28 on Reader Service Card

VIDEO TAPE DATA

A four-page brochure covering the 142 Series video tape is now available. The two-inch-wide, helical-scan video tape is designed specifically for optimum performance with the company's VR-1500/660 Series broadcast and closed-circuit videotape recorders. Bulletin #T160 will be supplied on request. Ampex

Circle No. 149 on Reader Service Card

PHOTO CREDITS

Page	Credit
6	University Sound
28, 30 (top)	Capitol Institute of Technology
30 (bottom)	RCA Institutes, Inc.
32 (top)	Sylvania Electric Products Inc.
32 (center)	Honeywell
32 (bottom)	Radiation Dynamics
33 (top left)	Bornes Engineering Co.
33 (top right)	Ferranti Electric
33 (center)	Northern Electric
33 (bottom)	ITT
56	Soliton Devices
60	Tung-Sol
88	BSR (USA) Ltd.

ELECTRONICS MARKET PLACE

COMMERCIAL RATE: For firms or individuals offering commercial products or services. 70¢ per word (including name and address). Minimum order \$7.00. Payment must accompany copy except when ads are placed by accredited advertising agencies. Frequency discount: 5% for 6 months; 10% for 12 months paid in advance.

READER RATE: For individuals with a personal item to buy or sell. 40¢ per word (including name and address). No Minimum! Payment must accompany copy.

GENERAL INFORMATION: First word in all ads set in bold caps at no extra charge. Additional words may be set in bold caps at 10¢ extra per word. All copy subject to publisher's approval. Closing Date: 1st of the 2nd preceding month (for example, March issue closes January 1st). Send order and remittance to: Hal Cymes, **ELECTRONICS WORLD**, One Park Avenue, New York, New York 10016

FOR SALE

JUST starting in TV service? Write for free 32 page catalog of service order books, invoices, job tickets, phone message books, statements and file systems. Oelrich Publications, 6556 W. Higgins Rd., Chicago, Ill. 60656.

GOVERNMENT Surplus Receivers, Transmitters, Sniperscopes, Radios, Parts, Picture Catalog 25¢. Meshna, Nahant, Mass. 01908.

METERS—Surplus, new, used, panel and portable. Send for list. Hanchett, Box 5577, Riverside, Calif. 92507.

INVESTIGATORS, FREE BROCHURE, LATEST SUBMINIATURE ELECTRONIC SURVEILLANCE EQUIPMENT. ACE ELECTRONICS, 11500-J NW 7TH AVE., MIAMI, FLA. 33168.

CONVERT any television to sensitive big-screen oscilloscope. Only minor changes required. No electronic experience necessary. Illustrated plans, \$2.00. Relco-A22, Box 10563, Houston, Texas 77018.

R.F. CONVERTERS World's largest selection. Also CCTV cameras, etc. Lowest factory prices. Catalog 10¢. Vanguard, 196-23 Jamaica Ave., Hollis, N.Y. 11423.

MUSIC LOVERS, CONTINUOUS, UNINTERRUPTED BACKGROUND MUSIC FROM YOUR FM RADIO, USING NEW INEXPENSIVE ADAPTER. FREE LITERATURE. ELECTRONICS, 11500-Z NW 7th Ave., MIAMI, FLORIDA 33168.

FREE ELECTRONICS (new and surplus) parts catalog. We repair multimeters. Bigelow Electronics, Bluffton, Ohio 45817.

DETECTIVES! Free brochures! Electronic Surveillance devices. SILMAR ELECTRONICS, 3476 N.W. 7th Street, Miami, Florida 33125.

SURVEILLANCE EQUIPMENT—NEW HIGH PERFORMANCE SUBMINIATURE MODELS. ELECTRONIC COUNTERMEASURE DEVICES TO PROTECT PRIVACY. FREE DATA: SECURITY ELECTRONICS-EW, 15 EAST 43RD STREET, NEW YORK, N.Y. 10017.

JAPANESE PRODUCTS CATALOG by air mail \$5, sea \$3. Intercontinental, CPO 1717, Tokyo, Japan.

**ANY RADIO · TV RECEIVING TUBE
32¢ EACH! \$29.00 PER 100!**

The price is not a mis-print! We have been supplying top service organizations for 15 years with our top quality new, used and factory-second receiving tubes! They are all individually boxed, branded, code-dated and guaranteed for 1 year! We have over 2500 types in stock continuously! You may order any type! Our stock covers 45 years of tube manufacturing!

If your order is under \$5.00 send 50¢ handling! All postage charges paid by Nationwide. Canadian and foreign please send approximate postage! Send for complete free tube list!

NATIONWIDE TUBE CO. (EW-468)
1275 STUYVESANT AVE.
UNION, N.J. 07083 (201) 688-1414

CRYSTALS . . . largest selection in United States at lowest prices. 48 Hr. delivery. Thousands of frequencies in stock. Types include HC6/U, HC18/U, FT-241, FT-171, etc. Send 10¢ for catalog with oscillator circuits. Refunded on first order. Jan Crystals, 2400E Crystal Dr., Fort Myers, Fla. 33901.

TREASURE HUNTERS! Prospectors! Relco's new instruments detect buried gold, silver, coins. Kits, assembled models. Transistorized. Weighs 3 pounds. \$19.95 up. Free catalog. Relco-A22, Box 10839, Houston, Texas 77018.

METAL—Treasure Detectors, most sensitive. Lowest priced. Free catalog. Jetco Instruments, Box 132-E, Huntsville, Texas 77340.

SURVEILLANCE COUNTERMEASURES BROCHURE \$1.00. ENGINEERING LABORATORIES, BOX 1036, ANDERSON, INDIANA 46015.

TRANSISTOR-Tube-Radio-Television-Phono, SIGNAL GENERATOR, \$4.00. Takoma Servicing School, 11808 Pittson Road, Wheaton, Maryland 20906.

DIAGRAMS, service information, Radio \$1.00, Television \$1.50. **HARTFORD,** 1760 Balsam, Highland Park, Illinois 60035.

NEW VOLTOMETER 20,000 ohms/volt with case. "Perfect" **MONEY BACK GUARANTEE.** \$10.95. United, Dept. EW5, Box 8690 Brightwood, Washington, D. C. 20011.

ELECTRONIC Ignition, various types. Free literature. Anderson Engineering, Epsom, N. H. 03239.

DUMONT 280 Oscillograph with manual. Make reasonable offer for shipment FOB Santa Fe. Catron, 826 Ranchitos, Santa Fe, N. Mex. 87501.

HOBBYISTS! \$40.00 ELECTRONIC PARTS \$1.98 —Postpaid! Typical assortment contains name brand tubes—semiconductors—relays—switches—capacitors—resistors—fuses—lamps, etc. Box 50, Delano, Minnesota.

TECH MANUALS, SOLD ON MILITARY SURPLUS AND CIVILIAN ELECTRONIC EQUIPMENT. GIVE MAKE, MODEL FOR MANUAL QUOTE. SLEP ELECTRONICS, DRAWER 178EW, ELLENTON, FLORIDA 33532.

DISPOSAL—\$80,000.00 hi-fidelity retail store inventory. New/used equipment: Ampex, Marantz, Fisher, others. Hewlett Packard test equipment. Free list—Marco Electronics, Box 336 D, Winter Park, Fla. 32789.

ELECTRONICS ENGINEERING AND INSTRUCTION

WANTED! TV—Radiomen to learn aircraft electronics servicing. Numerous job openings everywhere. Write: **ACADEMY AVIONICS,** Reno/Stead Airport, Reno, Nevada 89500.

ASSOCIATE Degree in Electronics Engineering earned through combination correspondence-classroom educational program. Free brochure. Grantham Technical Institute, 1505 N. Western Ave., Hollywood, Calif. 90027.

LEARN ELECTRONIC ORGAN SERVICING at home. All Makes including transistors. Experimental kit—troubleshooting. Accredited NHSC. Free Booklet. **NILES BRYANT SCHOOL,** 3631 Stockton, Dept. A, Sacramento, Calif. 95820.

FCC First Class License in six weeks—nation's highest success rate—approved for Veterans Training. Write Elkins Institute, 2603C Inwood Road, Dallas, Texas 75235.

HIGHLY effective home study course in Electronics Engineering Mathematics with circuit applications. Earn your Associate in Science Degree. Free literature. **COOK'S INSTITUTE OF ELECTRONICS ENGINEERING,** P.O. Box 36185, Houston, Texas 77036.

ELECTRONICS! Associate degree—29 months. Technicians, field engineers, specialists in communications, missiles, computers, radar, airborne. Start September, February. Valparaiso Technical Institute, Dept. N, Valparaiso, Indiana 46383.

R.E.I.'s famous (5) week course for the First Class Radio Telephone License is the shortest, most effective course in the nation. Over 98% of R.E.I. graduates pass F.C.C. exams for 1st class license. Total tuition \$350.00. Job placement free. Write for brochure Radio Engineering Institute of Electronics, 1336 Main Street, Sarasota, Florida 33577—or 3123 Gillham Road, Kansas City, Missouri 64109—or 809 Caroline Street, Fredericksburg, Virginia 22401.

DO-IT-YOURSELF

PROFESSIONAL ELECTRONICS PROJECTS — \$1.00 up. Catalog 25¢. **PARKS,** Box 15265B, Seattle, Wash. 98115.

URETHANE Foam. Direct from factory. Free catalog. Lists foam for cushions, mattresses, boats, upholstery—any home project. Perma-Foam, Inc., 605-H South 21st Street, Irvington, New Jersey 07111.

GET IT FROM GOODHEART!

EVERYTHING UNCONDITIONALLY GUARANTEED!

SILIC. RECTIF. 8000 PIV 400 MA. Large user's term. Invent., not reject! Slatco SLA08-2. Max: reverse, 2 uA; fwd drop, 8.2 v. Cost \$8 ea. Bakel. encapsul. 3Kx2x1" ht ea. **PAIR POSTPAID . . . \$5.30**

GRD. LOWEST-PRICED COUNTER to 220 or 510 mc! Like-new appearance; recent date Certif. of Calif. traceable to Nat. Bur. of Standards. With 5 books. ± 1 count ± .0001%. Hewl-Pack #224B with #225A & #225B or C. **WRITE FOR LOW REDUCED PRICES!**

BOONTON #225A AM/FM Sig. Gen. 10-500 mc. ASK! HEWL-PACK #208A AM Sig. Gen. 10-500 mc. ASK!

MARCONI FM DEVIATION METER TF-934, regularly \$800. Reads dev. w/ranges 5, 25, 75 kc. Has audio monitor. Made for MIL. 2 1/2-100 mc, easily reaches 1000 mc on harmonics; we include all instructions. Checked out, ready to use **\$249.50**

Brand New VHF revrs look like BC-453 Command but are 9-tube 108-125 mc. 2 uv sens; 2 rfs, 3 1P's; noise limr; ave. w/schem. Inst. with spline knob, & graph to set freq. by counting turns. A.R.C. Type 13B, 26v htr wiring; 7# ship wt. **\$22.50**
R32 is same but w/squelch; 14v htr wiring. **\$27.50**

R-23/ARC-5 Command revr 190-550 kc. 14.95
A.R.C. 12 #22 Command revr 540-1600 kc. 17.95
LM-14 freq. meter, .01% 125 kc-20 mc. 57.50
TS-323/UR freq. meter 20-480 mc., .001% 169.50
BC-221's OK \$67.50 **TS-175 OK** 127.50
CLOSING OUT Radio Receivers 88-4000 mc at **CRAZY LOW PRICES!** Ask for APR-4/4Y/CV-253 sheet.

ALL-BAND SSB RCVR BARGAIN: Hallcrafters R-45/ARR-7, 650 kc to 43 mc continuous. Voice, CW, MCW, aligned, grtd, w/book; 2-8R, 2-1P's, & meter; noise limr; 3 xtl, 3 non-xtl selec. **149.50** (ivity choices. Less pwr sply.)
60 cy pwr sply; \$30. SSB product detector; \$20

SP-600-JX Revr. 54-54 mc, Exc. Cond., w/book. 325.00

Super. EMT 6220Y 3 ph 20 kva Line V Regulator. 450.00
Sorans. 1000S 10 kva Line V Regulator. 695.00
And others from 250 VA up. Ask for Regular List. Automichron Cesium-Beam Freq. Standard. ASK!
Regulated Power Supplies, Meter Calibrators. ASK!
All kinds of AUDIO Test Equipment. ASK!
Standard Signal Generators CW/AM/FM/Sweep ASK!
Bridges, Potentiometers, other Lab Standards. ASK!
Electronic & Rotary Frequency Converters. ASK!
Noise & Field Strength Meters. ASK!

TIME PAY PLAN: Any purchase totalling \$180.00 or more, down payment only. **10%**

Above is a small sampling of our terrific inventory. We **ALSO BUY!** We want Tektronix scopes, Hewlett-Packard equip., Aeronut, radio-shop equip., etc. AND Military Communications of all kinds.

DO NOT ASK FOR CATALOG! ASK FOR SPECIFIC ITEMS OR KINDS OF ITEMS YOU NEED!

R. E. GOODHEART CO. INC.

Box 1220-A, Beverly Hills, Calif. 90213
Phones: Area 213, office 272-5707, messages 275-5342

"ARCTURUS" SALE

• Tube Bargains, to name just a few:

#6146 ..\$2.95	#5725/6AS6 79¢: 3 for \$2.00	#6AQ561¢
#6360 .. 3.50	#5842/417A\$2.50	#6BQ794¢
#6688 .. 3.50	#5847/404A 2.50	#6CG759¢
#6939 .. 3.50	#1AX249¢; 5 for.... 2.00	#6J649¢
#7025 .. 5.00	#6K759¢; 3 for.... 1.00	#6T980¢
#7788 .. 3.75	#12BN059¢; 3 for.... 1.49	#6U878¢
#2D21 .. .49	#25L659¢; 3 for.... 1.49	#12AU7 ..59¢

• Tube Cartons: 6AU6 etc. size, \$1.95 per 100. 6SN7 etc. size, \$2.35 per 100. 5U4GB size, \$2.75 per 100. 5U4G size, 03c each.

• Obsolete Tubes: #UX200, \$1.69; #80, \$1.20; #10Y, 69¢; etc.

• 7 Inch 90 degree TV bench test Picture Tube with adapter. No ion trap needed. Cat. #7BP7, \$7.99.

• Silicon Rectifier octal-based long-range replacement for #5U4, 5Y3, 5AS4, 5AW4, 5T4, 5Z4. With diagram. Cat. #Rect 1, 99¢ each.

• Silicon Rectifier replacement, octal based, for 0Z4. Cat. #Rect 2, 99¢ each.

• 10 Silicon Rectifiers, 750 MA., 50 to 300 p.i.v. Cat. #330F, 99¢ each.

• RCA—110 degree flyback transformer, latest type. Produces 18 KV. Includes schematic diagram application for any TV. Cat #BR-1 \$2.99.

• 5 Transistor Circuit Boards containing up to 6 transistors, plus diodes, resistors, capacitors, etc. Cat. #TB10, 99¢.

• Needles: values such as #AS22 Sapphire, 39¢; Diamond, 99¢.

• Color Yokes, 70 degree for all round color CRT's. Cat. #XRC70, \$12.95. 90 degree for all rectangular 19 to 25 inch color CRT's. Cat. #XRC90, \$12.95.

• Transistorized U.H.F. Tuners used in 1965 to 1967 TV sets made by Admiral, RCA, Motorola, etc. Removable gearing may vary from one make to another. Need only 12 volts d.c. to function. No filament voltage needed. Easy replacement units. Cat. #U.H.F. 567, \$4.95.

• Flyback Transformer in original carton. Made by Merit or Todd. Most with schematic drawing of unit. Please do not request specific type. Cat. #506, 99¢ each.

• Kit of 30 tested Germanium Diodes. Cat. #100, 99¢.

Send for our Free Catalog listing thousands of similar best buys in tubes, parts, kits, transistors, rectifiers, etc. Orders under \$5.00, add 50¢ handling charge. Include 4% of dollar value of order for postage. Canadian postage \$1.00 extra.

ARCTURUS ELECTRONICS CORP.

Phone: 201 - UN 4 - 5568

502 - 22nd St., Union City, N.J. 07087 Dept. MEW

CIRCLE NO. 124 ON READER SERVICE CARD

TUBES

TUBES, SEMICONDUCTORS, ELECTRONIC EQUIPMENT & COMPONENTS. Quality merchandise only! Serving engineers, Purchasing Agents, TV/HiFi Servicemen and Hams for 20 years. Write for Catalog or call 212-WA 5-7000. BARRY ELECTRONICS, 512 Broadway, New York, N.Y. 10012.

RECEIVING & INDUSTRIAL TUBES, TRANSISTORS, All Brands—Biggest Discounts. Technicians, Hobbyists, Experimenters—Request FREE Giant Catalog and SAVE! ZALYTRON, 469 Jericho Turnpike, Mineola, N.Y. 11501.

TUBES—33¢ each. Year guarantee. Tuner Cleaner \$1.09. Free catalog. Cornell, 4213-W University, San Diego, Calif. 92105.

DON'T BUY TUBES—Radio, TV-Xmitting, special-purpose types until you get our price list! Lowest prices in U.S.A. 5,000 types—Guaranteed Brand New. Send postcard for TV—Special Purpose Price List. UNITED RADIO COMPANY, P.O. BOX 1000, NEWARK, N.J. 07101.

WANTED

QUICKSILVER, Platinum, Silver, Gold. Ores Analyzed. Free Circular. Mercury Terminal, Norwood, Mass. 02062.

QUICK CASH . . . for Electronic Tubes, Semiconductors, Equipment (Receivers, Transmitters, Scopes, Vacuum Variables, etc.) Send lists now! Write: BARRY ELECTRONICS, 512 Broadway, New York, N.Y. 10012 (212-WA 5-7000).

PERSONALS

MAKE FRIENDS WORLDWIDE, promote international understanding, join Europe's leading correspondence club. Illustrated brochure free. HERMES, Box 17/33, 1 Berlin 11, Germany.

If you are 30-60, if you live in the NYC area, and if you are sometimes lonesome and would enjoy intelligent, interesting companionship, write: TWogether Associates, Dept. 7, 38 East 57 St., New York City 10022.

CLASSIFIED ADVERTISING ORDER FORM

Please refer to heading on first page of this section for complete data concerning terms, frequency discounts, closing dates, etc.

1	2	3	4	5
7	6	8	9	10
11	12	13	14	15
16	17	18	19	20
21	22	23	24	25
26	27	28	29	30
31	32	33	34	35

_____ Words { @ .40 Reader Rate } = \$ _____
 { @ .70 Commercial Rate }

Insert _____ time(s) Total Enclosed \$ _____

NAME _____

ADDRESS _____

CITY _____ STATE _____ ZIP _____

SIGNATURE

WORD COUNT: Include name and address. Name of city (Des Moines) or of state (New York) counts as one word each. Zip Code numbers not counted. (Publisher reserves right to omit Zip Code if space does not permit.) Count each abbreviation, initial, single figure or group of figures or letters as a word. Symbols such as 35mm, COD, PO, AC, etc., count as one word. Hyphenated words count as two words. EW-468

PLANS AND KITS

ELECTRONIC drum plans 50¢. Electronic marimba plans \$2.00. Free catalog of other unusual items. Franks Scientific Co., P.O. Box 156, Martelle, Iowa 52305.

INTEGRATED CIRCUIT KITS; COMPUTER LOG-IC, IC's; others. Catalogue free. Kaye Engineering, Box 3932-B, Long Beach, California 90803.

RECORDS

SPECIAL INTEREST RECORDS AVAILABLE, PRODUCED BY THE EDITORS OF THE WORLD'S LEADING SPECIAL INTEREST MAGAZINES. SEND FOR FREE CATALOG, RECORD CATALOGUE, ZIFF-DAVIS PUBLISHING COMPANY, ONE PARK AVENUE, NEW YORK, N.Y. 10016.

YOUR SERVICE AND QUALITY LEADER

We promise to supply you with the highest quality products at the most attractive prices with the fastest service in the industry.

TRIACS

TO-66
5 AMP

PRV	100	200	300	400	500
	.90	1.40	1.75	2.25	2.60

ZENERS 1 Watt 6-33V \$.50
10 Watt 6-200V \$.75
50 Watt 7-200V \$1.75

- SIM to 2N3429 (NPN). SI 7/8" stud, min HFE of 30, 7.5 Amps. 175 watts, V_{CE} of 75\$1.75
- SILICON BILATERAL SWITCH. Replaces two SCR's by firing in either direction when breakdown voltage is exceeded. Used in light dimmers, etc.2/\$1.00

- N-CHANNEL FET'S TO-18 plastic units, low noise, low leakage, 25 volts source to gate, 50 ma gate current Gain of 2000-9000 μ mho's. \$1.00
- NEON LIGHT OR NIXIE TUBE DRIVERS. An NPN, TO-18, SI Transistor. With a VCBO of 120 3/\$1.00

- SIM. to 2N2875 (PNP). Silicon 20 watts with 30 MHz cut off \$.75
- High Voltage NPN 150V. VCBO at 2.5A., High HFE in TO-66 pack\$.75
- 500 HFE plastic transistors. NPN, TO-18, SI unit similar to 2N35654/\$1.00

Silicon Power Rectifiers

PRV	3A	12A	20A	40A
100	.09	.30	.40	.75
200	.16	.50	.60	1.25
400	.20	.70	.80	1.50
600	.30	1.00	1.20	1.80
800	.40	1.25	1.50	
1000	.55	1.50	1.80	

Terms: FOB Cambridge, Mass. Send check or Money Order. Include Postage, Average Wt. per package 1/2 lb. No C.O.D.'s. Minimum Order \$3.00

Rated companies 30 days net TELEPHONE (617) 547-4005

POST OFFICE BOX 74B
SOMERVILLE, MASS. 02143
featuring transistors, rectifiers and components
SEND FOR OUR SPRING CATALOG
Business Address: 325 Elm St., Cambridge, Mass.

INTEGRATED CIRCUITS



- SR Flip Flops\$.90
- SR Clocked Flip Flops\$1.15
- SRT Flip Flops\$1.15
- Dual NAND Nor Gates\$1.00
- 8 Input NAND Nor Gates\$1.00
- Dual and Gates\$1.00
- Quad NAND Nor Gates\$1.00
- TO-85 flat pack with holder. Guaranteed to work. They come complete with schematic, elect. characteristic sheet & some typical applications.

Top Hat & Epoxy 1 AMP

PRV	100	200	400	600	800	1000	1200	1400	1600	1800
	.07	.09	.12	.16	.22	.35	.50	.65	.80	.90



Silicon Control Rectifiers

PRV	3A	7A	20A	70A
50	.35	.45	.70	
100	.50	.65	1.00	4.00
200	.70	.95	1.30	8.00
300	.90	1.25	1.70	
400	1.20	1.60	2.10	12.00
500	1.50	2.00	2.50	
600	1.80	2.40	3.00	16.00
700	2.20	2.80		
1000			5.00	

Reconditioned & Used FM 2-WAY RADIO EQUIPMENT

Here's a small part of enlarged inventory now on hand for practically everything you need—at savings!

SENSATIONAL SAVINGS ON 450-470 MC MOBILE UNITS

RCA—CMU15A, 6/12Volts/15Watts Complete with accessories.....\$ 68

RCA CMUE 12 Volts/15 Watts Complete with accessories.....\$158 With quiet channel.....\$183

RCA—CMU15B, 6/12Volts/15Watts Complete with accessories.....\$ 88

MOTOROLA 15 to 18 Watts Complete with Accessories

T44A—6 or 12 volts.....\$ 48
T44A6—6/12 volts.....\$ 58
T44A6A—6/12 volts.....\$ 68
T44AAV—6/12 volts.....\$ 88

GENERAL ELECTRIC 4ES14A1—450-470 MC 6/12 volts, less accessories—12 to 15 Watts.....\$ 38

Voice Commander



132 to 172 MC, 1W 9.5" x 5.3" x 1.7" Lowest price ever, including brand New Rechargeable Nickel Cadmium Battery Pack

\$148

If crystal & tuning is desired add \$45.00 Battery charger for these units \$16.00 Write for Quantity Prices

VOICE COMMANDER Monitor Receiver only—Tuned & Crystalled with dry Batteries **\$78**

We Buy Late Model Equipment for Cash Send For '68 Catalog—Write; Wire or Phone!



GREGORY ELECTRONICS CORPORATION
249 RT. 46, Saddle Brook, N.J. 07662
Phone: (201) 489-9000

CIRCLE NO. 110 ON READER SERVICE CARD TAPE AND RECORDERS

BEFORE renting Stereo Tapes, try us. Postpaid both ways—no deposit—immediate delivery. Quality—Dependability—Service—Satisfaction—prevail here. If you've been dissatisfied in the past, your initial order will prove this is no idle boast. Free Catalog. Gold Coast Tape Library, Box 2262, Palm Village Station, Hialeah, Fla. 33012.

SCOTCH Recording Tapes. Tape Recorders. Catalog 10¢. Tower, Lafayette Hill, Pa. 19444.

RENT Stereo Tapes—Over 2,500 Different—all major labels—free brochure. Stereo-Parti, 1616 —E. W. Terrace Way, Santa Rosa, California 95404.

TAPEMATES make available to you **ALL 4-TRACK STEREO TAPES—ALL LABELS**—postpaid to your door—at tremendous savings. For free brochure write: **TAPEMATES**, 5727 W. Jefferson Blvd., Los Angeles, California 90016.

RENT STEREO TAPES—75¢ week. Catalog. Art's Tape Service, 1613½ North Mariposa Ave., Hollywood, Calif. 90027.

TAPE RECORDER SALE. Brand new, nationally advertised brands, \$10.00 above cost. Special prices on HI-FI Components and color television. Arkay Sales, 1028-B Commonwealth Avenue, Boston, Mass. 02215.

STEREO Tapes, Save 30% and up; no membership or fees required; postpaid anywhere U.S.A. Free 70-page catalog. We discount batteries, recorders, tape/accessories. Beware of slogans, "not undersold," as the discount information you supply our competitor is invariably reported to the factory. **SAXITONE**, 1776 Columbia Road, N. W., Washington, D. C. 20009.

WHOLESALE—48-track **STEREOTAPES**—Car, Home **PLAYERS**—CB, Recorders, **MUSICO**, Box 2705, Montgomery, Alabama 36105.

HI-FI Components, Tape Recorders at guaranteed "We Will Not Be Undersold" prices. 15-day money-back guarantee. Two-year warranty. No Catalog. Quotations Free. Hi-Fidelity Center, 239 (LT) East 149th Street, New York 10451.

BLANK CARTRIDGE TAPES—34 minute 4 or 8 track—60 minute cassette—\$1.50 each. Douglas Sales, Dept. RR, P.O. Box 5909, Chicago, Illinois 60605.

MIDWEST TAPE SERVICE—Rent Popular Stereo Tapes—75¢ week. Free catalog. 7606 Eastlake Terrace, Chicago, Illinois 60626.

SCOTCH Tape at discount prices. Rent pre-recorded tapes—no dues, east coast's finest selection. Postage paid. The Tape Library, Box 8146, D.C. 20024.

BELTS for Grundig, Akai, Telefunken. Give model number. Public Sound, 9385 Bird Road, Miami, Florida 33165.

EMPLOYMENT OPPORTUNITIES

RADIOTELETYPE TECHNICIANS—The U.S. Information Agency needs Technicians to service radio receivers and teleprinters overseas. Must have had at least two years such experience. Positions entail 80% overseas travel. Salary ranges from \$8,351 to \$9,267 per annum depending on qualifications, plus travel and per diem. Must be U.S. citizens. Send applications to U.S. Information Agency, IPT/R, 1776 Penna. Ave., N. W., Washington, D. C. 20547. An Equal Opportunity Employer.

RECTIFIERS & TRANSISTORS
Silicon Diodes

Amps	50 PIV	100 PIV	150 PIV	200 PIV
.75*	.05	.07	.08	.00
1	.08	.09	.13	.18
3	.15	.23	.32	.40
18**	.09	.20	.30	.35

Amps	300 PIV	400 PIV	500 PIV	600 PIV
.75*	.11	.13	.15	.17
3	.15	.18	.20	.22
15	.25	.30	.35	.40
18**	.43	.75	.90	1.10
35	.85	1.15	1.35	1.60

Amps	700 PIV	800 PIV	900 PIV	1600 PIV
.75*	.19	.21	.22	.26
3	.28	.34	.36	.40
15	1.19	1.23	1.29	1.35
35	1.70	1.80	1.90	2.10

**Press Fit Pkg., *Top Hat or Flangless

10 WATT SIL. ZENER STUD 20% 12-200 V. .59¢ ea.
1 WATT ZENER DIODE, axial leads 20% .25¢ ea.
 8-200V .25¢ ea.
SIL. DIODE 1500 PIV 300 ma. .20¢ ea.
HI-VOLTAGE Silicon Epoxy Diodes 2 1/2"x3/8"x1/2" .75¢ ea.
HOFFMAN 3000 PIV 200 ma. .85¢ ea.
HOFFMAN 6000 PIV 200 ma. 1.49¢ ea.
SILICON POWER TRANSISTORS 80V 2N1724 1.49¢ ea.
SIL. POW. TRANSISTOR 20V TO53 Case NPN 4/1.00
SIL. POW. TRANSISTOR 60V TO53 Case NPN 59¢ ea.
 Various—Voltage Variable Capacitor
 27, 47, or 100 pf at 4V, 411 new. .125¢ ea.
SIL. DIODES, 1N200 series ass't new. .25/1.00
GER. DIODES, glass, new exceeds 1N34. .25/1.00
2N 1047B Sil. Pow. 80V TO57. .49¢ ea.
2N 1050 Sil. Pow. 120V TO57. .65¢ ea.
2N 456A 7A. 40V 150W Ger. Pow. TO3. 4/1.00
2N 1021 Ger. Pow. 7A, 100V, TO3. .60¢ ea.
2N 1300 Series NPN or PNP .10/1.00

2N 2151 Sil. Pow. NPN 80V .50¢ ea.
2N 118 Sil. Pow. NPN 45V .50¢ ea.
2N 34 Silicon Tetrode 400 .75/1.00 ea.
SIL. POW. TRANSISTOR 40V TO57 NPN. .39¢ ea.
SIL. POW. TRANSISTOR 40V TO53 NPN. .39¢ ea.
SIL. POW. TRANSISTOR 60V TO57 NPN. .59¢ ea.
2N 1142 Ger. Small Signal Hi-Freq. TO5 80V 3/1.00
INTEGRATED CIRCUITS TO5 .20/1.00
INTEGRATED CIRCUITS Dual In-Line .20/1.00
2N 2553 GER. MED. POW. HEATSINK TRANSISTOR PNP .59¢ ea.
 12V TO5 Case 10 + gain NPN or PNP resistors .20/1.00

SILICON CONTROLLED RECTIFIERS

PRV	.75A*	7A	16A	PRV	.75A*	7A	16A
25	.07	.14	.24	300	.40	.95	.85
30	.11	.24	.35	400	.75	1.70	2.20
100	.30	.36	.60	500	1.25	1.15	2.50
150	.30	.45	.75	600	1.20	1.60	1.95
200	.40	.55	.85	*Top Hat SCR Flat Bottom			

ALL MERCHANDISE GUARANTEED OR REFUND. \$3.00 MINIMUM ORDER PLUS POSTAGE. FREE \$1.00 IN MERCHANDISE WITH EACH \$10.00 ORDER. ORDERS FILLED PROMPTLY.

ELECTRONIC COMPONENTS CO.
BOX 2902, BATON ROUGE, LA. 70821

CIRCLE NO. 113 ON READER SERVICE CARD

G&G CATALOG!
NEW 24 Pages Military Electronic Gear
SEND 25¢ - Refunded with first order

AN/APR-4Y FM & AM RECEIVER "FB" FOR SATELLITE TRACKING!

High precision lab instrument, for monitoring and measuring frequency and relative signal strength, 38 to 4000 Mc. in 5 tuning ranges. For 110 V 60 cycle AC. Built-in power supply. Original circuit diagram included. Checked out, perfect. **\$88.50**
LIKE NEW

All Tuning Units Available for Above

LORAN APN-4 FINE QUALITY NAVIGATIONAL EQUIPMENT

4-Channel long range dual units, will determine exact geographic position of your boat or plane. Indicator and receiver complete with all tubes and crystal. **INDICATOR, D-66/APN-4, and RECEIVER \$88.50**
R-9B/APN-4, complete with tubes, Exc. Used

LORAN R-65/APN-9 RECEIVER & INDICATOR

4-Channel single unit system, used in ship, land aircraft. Determines position by radio signals from known xmitters. Accurate to within 1% of distance. Complete with tubes and crystals. **\$88.50**
Like New Condition. All accessories for Loran Equipment in stock.

BC-929 3-Inch Scope, with all tubes. LIKE NEW \$16.95

Conversion instructions, with diagram, for 110 V AC operation \$ 65

R-4/ARR-2 RECEIVER, 234-258 Mc, Tunable. Complete with 11 tubes, NEW \$11.95
Dynamotor (24VDC) for ARR2 \$2.45

BC-645 TRANSCIVER 435 to 500 Mc, convertible for Ham or Citizens' bands, Voice or Code. Brand new, with 15 tubes \$16.95
Dynamotor, Antenna, Plugs, All accessories available.

VISIT OUR NEW SHOWROOM AT 45 WARREN STREET, N.Y.C.

SCR-274-N, ARC-5 COMMAND SET HQ!

Freq. Range	Type	Exc. Used	BRAND NEW
RECEIVERS, Complete with Tubes			
190-550 Mc.	BC-453	\$18.95	\$23.50
3-6 Mc.	BC-454	\$16.50	\$21.50
6-9.1 Mc.	BC-455	\$14.05	\$19.95
1.5-3 Mc.	R-25	\$21.50
TRANSMITTERS, Complete with Tubes			
4-5.3 Mc.	BC-457	\$ 6.95	\$11.95
5.3-7 Mc.	BC-458	\$ 6.95	\$11.95
7-9.1 Mc.	BC-459	\$17.95	\$22.50
2.1-3 Mc.	T-18	\$10.95
3 Mc.	T-19	\$10.50	\$14.95
MODULATOR, Complete with 3 Tubes			
Voice	BC-456	\$ 2.75	\$ 4.95
All Command Set Accessories in Stock			
5CR-625 MINE DETECTOR			
BC-1206-C Beacon Rcvr. 200-400 Mc. NEW \$32.50			
BC-1206-C as above, used \$ 9.95			
SCR-522 Transmitter-Receiver, Like New \$39.50			

EE-8 FIELD PHONES

Checked out, perfect working order. Complete with all parts. Excellent Condition. LIKE NEW! **\$16.95**
Each

Please include 25% Deposit with order—Balance C.O.D., or Remittance in Full. 50¢ Handling Charges on all orders under \$5.00. All shipments F.O.B. Our Warehouse, N.Y.C. All Merchandise subject to Prior Sale and Price Change.

G & G RADIO SUPPLY COMPANY
Telephone: (212) CO 7-4605
75-77 Leonard St., New York, N.Y. 10013

Rechargeable Eveready Ni-Cad Batteries

8.75 v.d.c., 500 ma. hr. (7 dry button cells) size 2 3/4" long x 1 1/2" dia., suitable for portable phones, radios, test bench, labs. \$15.00 value. **\$5.97 ea.**

One charger free with purchase of ten batteries.

Battery charger for the above or similar battery. **\$3.97**

Small DC Motor, Swiss precision made, operates on 3.4 v.d.c. suitable for models, battery phone, etc. **\$1.27**

Same motor as above with gear chain, high torque, 4-5 rpm suitable for display, etc. **\$1.96**

Sennheiser Model 407hn, directional, dynamic microphone (West German Mfg.) high and low impedance, excellent quality for voice and music. Limited quantity. **\$9.97**

All merchandise is brand new and sold on a money back basis if not satisfied.

PEAK ELECTRONICS CO.
66 W. Broadway, N.Y., N.Y. 10007, 212-962-2370

U.S. GOV'T ELECTRONIC SURPLUS

• Nationally Known-World Famous SURPLUS CENTER offers finest, most expensive, Government Surplus electronic units and components at a fraction of their original acquisition cost.

ORDER DIRECT FROM AD or WRITE FOR CATALOGS

STANDARD DIAL TELEPHONE

• (ITEM #715) - Standard, commercial telephone same as used throughout U.S.A. Attractive polished black, like new condition. Use as extension phone to private systems or connect several phones together for local intercom system. Full instructions are furnished. Wt. 9 lbs. Original Cost \$54.50. **F.O.B. \$7.50**



STEP-BY-STEP AUTOMATIC SWITCH

• (ITEM #738) - Amazing "up-and-around", electro-magnetic telephone switch. Dial any bank pair from 1 to 100. Make your own telephone system. Can also be used to remotely control up to 100 circuits over a single pair of wires.

• One of our FOUR STAR bargains. Comes complete with data, one dial and one line bank. Size, 5" x 7" x 15". Wt. 16 lbs. Cost Gov't Over \$73.00. Complete; Switch, cover, dial, line bank, instructions..... **F.O.B. \$9.95**



TYPICAL BUYS FROM OUR 1968 CATALOGS

- \$ 350.00 - Geared 2-hp Battery Golf Car Motor **\$26.95**
- \$ 15.00 - Westinghouse DC Ammeter, 0 to 300 **\$ 7.11**
- \$ 40.00 - Vacuum/Pressure Pump, 12-VDC **\$11.95**
- - - 80-MW Walkie-Talkies, Per Pair **\$19.60**
- - - Deluxe, Multi-Range, AC/DC Tester **\$ 8.98**

SPECIAL SALE

Correspondence Course In ELECTRICAL ENGINEERING



Sells For \$10.79 Outside U.S.A. **\$8.79** Postpaid In U.S.A.

• (ITEM #A181) - Wonderful chance to obtain technical training at Amazing Low Cost! Lincoln Engineering School has suspended its Correspondence Courses because of increased operating costs. We offer a limited number of the school's complete Electrical Engineering Course but without the examination paper grading service. The course consists of 14 lesson unit books. Each book has the regular exams, and in a separate section, "Standard Answers" to each exam question.

• Course is well written, easy to understand, profusely illustrated. Reader's Digest size, easy to carry and study in spare time. Many Lincoln Engineering School students holding excellent jobs as a result of E.E.S. training. Course contains latest information on transistors, silicon diodes, etc. Additional book on how to build and operate a "Home Laboratory and Experimental Bench" furnished with each course.

SEND 25¢ COIN OR STAMPS FOR 3 MAIN CATALOGS

All Items FOB Lincoln Money Back Guarantee

SURPLUS CENTER

DEPT. EW-048 LINCOLN, NEBR. 68501

HIGH FIDELITY

FREE! Send for money saving stereo catalog #E4W and lowest quotations on your individual component, tape recorder or system requirements. Electronic Values Inc., 200 West 20th Street, N.Y., N.Y. 10011.

HI-FI Components, Tape Recorders at guaranteed "We Will Not Be Undersold" prices. 15-day money-back guarantee. Two-year warranty. No Catalog. Quotations Free. Hi-Fidelity Center, 239 (L) East 149th Street, New York 10451.

HI-FI EQUIPMENT—Get Our "ROCK BOTTOM" prices on NAME BRAND amplifiers—tuners—tape-recorders—speakers **FRANCHISED—59 YEARS IN BUSINESS.** Write for this month's specials—NOW! Rabson's 57th St., Inc., Dept. 569, 119 W. 57th St., New York, New York 10019.

LOW, LOW quotes: all components and recorders. Hi-Fi, Roslyn, Penn. 19001.

HI-FI components, tape recorders, sleep learn equipment, tapes. Unusual Values. Free catalog. Dressner, 1523 R Jericho Turnpike, New Hyde Park, N.Y. 11040.

MUSIC

SWISS Musical Movements. Electrical-Mechanical. Spielman, 131 West 42nd, New York 10036.

GOVERNMENT SURPLUS

JEEPS Typically From \$53.90. . . Trucks From \$78.40. . . Boats, Typewriters, Airplanes, Electronic Equipment, Photographic Equipment, used. 100,000 Bargains Direct From Government. Complete Sales Directory and Surplus Catalog \$1.00 (Deductible First \$10.00 Order). Surplus Service, Box 820-K, Holland, Michigan 49423.

AUTHORS' SERVICES

AUTHORS! Learn how to have your book published, promoted, distributed. FREE booklet "ZD," Vantage, 120 West 31 St., New York 10001.

HYPNOTISM

FREE Hypnotism, Self-Hypnosis, Sleep Learning. Catalog! Drawer H400, Ruidoso, N.M. 88345.

SELF-HYPNOSIS for self-improvement. Safe, effective! Free literature. McKinley, Dept. T-3, Box 3038, San Bernardino, California 92404.

HYPNOTIZE SUCCESSFULLY—or money refunded! Complete illustrated course—including Self-Hypnosis \$1.00. Arthur Fowler, Box 4396, Woodbury, New Jersey 08096.

AMAZING HYPNOTIC record kit releases fantastic mental power! Free offer expires soon. Write: Forum, Studio AA4, 333 North Michigan, Chicago 60601.

PHOTOGRAPHY—FILM, EQUIPMENT, SERVICES

MEDICAL FILM—Adults only—"Childbirth" one reel, 8mm \$7.50; 16mm \$14.95. International W. Greenvale, Long Island, New York 11548.

SCIENCE Bargains—Request Free Giant Catalog "CJ"—148 pages—Astronomical Telescopes, Microscopes, Lenses, Binoculars, Kits, Parts, War Surplus bargains. Edmund Scientific Co., Barrington, New Jersey 08007.

STAMPS

RUSSIA HIGH-VALUE COLLECTION. 32 different Russia—some over 50 years old! Commemoratives. Czarist Issues, Airmails. Catalog price \$2.99. Special Get-Acquainted Offer—all for only 10¢! H. F. Harris, Dept. GG-13, Boston, Mass. 02117.

RUBBER STAMPS

RUBBER ADDRESS STAMP \$1.50. SIGNATURE \$3.50. FREE CATALOG. JACKSON, BOX 443-G, FRANKLIN PARK, ILL. 60131.

BOOKS

MANUALS for surplus electronics. List 15¢. BOOKS, Box 804, Adelphi, Maryland.

33¢

PER TUBE

100 TUBES OR MORE:
30¢ PER TUBE

Special!

With every \$10 Order

25¢

per tube

(No Limit) from this list.

6AG5
6AQ5
6AU6
6CB6
6J6
6SN7
6S4
6W4

CORNELL One Year TUBES Guaranteed

Tubes are new or used and so marked Labeled Individually Boxed, Branded and Code Dated

OZ4	3BZ6	6AB4	6AT6	6BA6	6BQ6	6CG7	6EA7	6K7	6SN7	6X4	12AD6	12BE6	12SQ7	77
1B3	3DG4	6AC7	6AT8	6BC5	6BQ7	6CG8	6EM5	6Q7	6SQ7	6X8	12AE6	12BF6	25L6	78
1J3/1K3	5U4	6AG5	6AU4	6BD6	6BZ6	6CM7	6F6	6S4	6SR7	7A7	12AF6	12BH7	25Z6	84/6Z4
1H5	5U8	6AK5	6AU5	6BG6	6C4	6CZ5	6GH8	6SA7	6U7	7AB	12A7	12BL6	35W4	5687
1L4	5V4	6AL5	6AU6	6BJ6	6C6	6D6	6H6	6SH7	6U8	7B6	12A7	12BY7	35Z3	6350
1L4	5Y3	6AN8	6AV6	6BL7	6CB6	6DA4	6J5	6SJ7	6V6	7C5	12AX7	12C5	50L6	6463
1U4	6A6	6AQ5	6AW8	6BN4	6CD6	6DE6	6I6	6SK7	6W4	7N7	12BA6	12CA5	24	7044
1X2	6A8	6AS5	6AX4	6BN6	6CF6	6DQ6	6K6	6SL7	6W6	7Y4	12BD6	12SN7	27	

Other tubes and CRT's at low prices—send for free list

NO SUBSTITUTIONS WITHOUT YOUR PERMISSION • YOUR ORDER FREE IF NOT SHIPPED IN 24 HRS.

TRANSISTORS

FAIRCHILD SEMICONDUCTOR

FOR—RADIO—TV—HI-FI—REPAIRS

ORDER CORNELL PART NO.	PNP	NPN	MIXED OSC CONV	PNP	NPN	PNP	NPN	AI DRIVER
	#RFP	#RFN	#MOP	#MON	#RFP	#RFN	#RFP	#RFN
REPLACEMENT FOR	ET-12 AA3	ET-13 AA3	ET-1 AA1	ET-8 AA2	ET-2 AA1	ET-9 AA1	ET-4 AA1	ET-11 AA1
	79 79	69 69	69 69	69 69	79 79			

Prestige & Success are yours as an ELECTRONIC EXPERT

COMPLETE RADIO SERVICING AND BASIC ELECTRONICS COURSE ONLY \$3.00 (\$2.50 + 50¢ postage charge)

NEW PRACTICAL TV TRAINING COURSE ONLY \$3.50 (\$3.00 + 50¢ postage charge)

Both above courses **\$6.00**

TUBE CARTONS

HIGH GLOSS RED & BLACK CLAY COATED With Built in Diagonal Partitions

SIZE	FOR TUBE SIZE	PRICE PER 10 CARTONS (Shipping Inc.)	PRICE PER 100 CARTONS (Shipping Inc.)
MIN.	6AU6	.29	2.59
GT.	6SN7	.39	3.49
LG. GT	5U4GB	.59	5.29
G.	5U4G	.89	7.99

all purpose ELECTRONIC CLEANER

89¢ plus 70¢ shipping

FREE

Send for CORNELL'S NEW 1968 CATALOG!!!

PICTURE TUBES! \$3!

MANY NEW ITEMS!!!

FREE

CORNELL

Dept. EW-4—4217 UNIVERSITY AVE.
SAN DIEGO, CALIFORNIA 92105

TERMS: ORDERS OVER \$5.00: Add 3¢ per tube shipping. Prepay in full and avoid C.O.D. charges. Send \$3.00 deposit on C.O.D. orders. No 24 hr. free offer on personal checks orders.

ORDERS UNDER \$5.00: Add 3¢ per tube shipping plus 50¢ handling.

CANADIAN AND FOREIGN ORDERS: Add approximate postage. No C.O.D. orders.

COMBINE VARIED ITEMS TO BRING YOUR ORDER OVER \$5.00

102

CIRCLE NO. 118 ON READER SERVICE CARD

ELECTRONICS WORLD

BIG CATALOG

World's "BEST BUYS" in GOV'T. SURPLUS Electronic Equipment

TELEVISION TELEMETER

TELEMETER PAY TELEVISION PROGRAM

SELECTOR—Choice of 3 programs that are tone operated in the VHF band, with provisions for depositing the amount of money required for each program as indicated on the coin register, and that also shows a credit balance when an over-payment is made. A pre-recorded tape will give program information when desired. With Tubes: 1/12BH7, 1/6BE6, 1/6DA8, 2/6DB; 4" speaker, coin mechanism, tape magazine, etc. Size: 15 x 7 x 7. Wt.: 25 lbs. #1001/5 **\$14.95**

LM FREQUENCY METER

LM NAVY TYPE FREQ. METER: 125-20,000
KC crystal calibrated indicating equipment, heterodyne type; accuracy .01 to .02 depending on frequency. With modulation, 500 cycle. Voltage required 12/24 for Fil. and 180 @ 3 MA/475 VDC @ 20 MA. With 1000 KC crystal & tubes. Also calibration book. Units have been used and may need replacement of some switches or minor parts. Otherwise guaranteed serviceable. Size: 7 1/2 x 7 1/2 x 7. Wt.: 15 lbs. Price—(As described above) **\$24.95**
Or: With All Parts: **\$29.50**
With All Parts, & Checked: **\$39.50**

RADIATION DETECTOR

AN/PDR-27 RADIAC SET
Is a portable, water-tight, battery operated radiation detector and indicator. It is capable of detecting and measuring Beta and Gamma radiations together—or Gamma radiation alone. The test unit can be carried by hand or by the shoulder strap. The Probe is attached to the main unit by a coiled cord. Visual indication is provided by the radiac meter, aural indication is provided by the headphones. Battery voltage required: 135 VDC & 1.5 VDC. Also included: 302AX, 1/6V4, 2 GM tubes BS-1 & 2. Headset and Manual contained in metal carrying case: 9 1/2 x 15 x 10 3/4". Wt.: 28 lbs. Price—(As described above) **\$19.95**

BIG FREE CATALOG—Send for your copy today!
Address Dept. EW • Prices F.O.B. Lima, O. •
25% Deposit on C.O.D.'s

FAIR RADIO SALES
1016 E. EUREKA • Box 1105 • LIMA, OHIO • 45802

EDUCATIONAL OPPORTUNITIES

LEARN While Asleep, hypnotize with your recorder, phonograph. Astonishing details, sensational catalog free! Sleep-Learning Association, Box 24-ZD, Olympia, Washington 98501.

LEARN WHILE ASLEEP. Miraculously build Mind Power, achieve Self Confidence, improve Health, gain Success. Method 92% effective. Details free. ASR Foundation, Box 7021EG Henry Clay Station, Lexington, Kentucky 40502.

USED Correspondence Courses and Books sold and rented. Money back guarantee. Catalog free (Courses Bought). Lee Mountain, Pisgah, Alabama 35765.

INVENTIONS WANTED

PATENT SEARCHES, \$6.00! FREE "Invention Record"/Information. Miss Hayward, 1029HE Vermont, District of Columbia 20005.

INVENTIONS - IDEAS developed Cash/Royalty Sales. Member: United States Chamber Commerce. Raymond Lee, 230-GE Park Avenue, New York City 10017.

INVENTORS! Receive free invention analysis at no risk to you. Send for FREE disclosure form today. New York Invention Service, Dept. 19, 160 Broadway, New York, N.Y. 10038.

INVENTORS. We will develop, help sell your idea or invention, patented or unpatented. Our national manufacturer clients are urgently seeking new items for outright cash sale or royalties. Financial assistance available. 10 years proven performance. For free information, write Dept. 42, Wall Street Invention Brokerage, 79 Wall Street, New York, N.Y. 10005.

EMPLOYMENT INFORMATION

FOREIGN and USA job opportunities available now. Construction, all trades. Earnings to \$2,000.00 monthly. Paid overtime, travel, bonuses. Write: Universal Employment, Woodbridge, Connecticut 06525.

BUSINESS OPPORTUNITIES

INVESTIGATE ACCIDENTS: Earn to \$1000 monthly. Men urgently needed. Car furnished. Business expenses paid. No selling. No college education necessary. Pick own job location. Investigate full time or earn to \$8 hour spare time. Write for FREE information. No obligation. Universal Schools, CZ-4, 6801 Hillcrest, Dallas, Texas 75205.

FREE CATALOGS. Repair air conditioning, refrigeration. Tools, supplies, full instructions. Doolin, 2016 Canton, Dallas, Texas 75201.

I MADE \$40,000.00 YEAR by mailorder! Helped others make money! Start with \$10.00—Free proof. Torrey, Box 318-N, Ypsilanti, Mich. 48197.

FREE BOOK "990 Successful, Little-Known Businesses." Work home! Plymouth-245A, Brooklyn, New York 11218.

MAKE CRIME PAY. Sell electronic burglar alarm full or part time. Not a gimmick, good profits. Vortex Mfg. Co., RR #2, Box 189, Charlestown, Ind. 47111.

REPAIRS AND SERVICES

SPEAKER REPAIR. Hi-Fi, guitar, organ speakers reconed good as new at fraction of new speaker price. For details and Reconing Center in your area write: Waldom Electronics, Inc., Dept. EW, 4625 W. 53rd St., Chicago, Ill. 60632.

MISCELLANEOUS

WINEMAKERS: Free illustrated catalog of yeasts, equipment. Semplex, Box 7208, Minneapolis, Minn. 55412.

SPARE TIME OPPORTUNITY—MONEY. WE PAY at the rate of \$10 hr. for NOTHING but your opinions, written from home about our clients' products and publications, sent you free. Nothing to buy, sell, canvass, or learn. NO SKILL. NO GIMMICKS. Just honesty. Details from RESEARCH, ZD-3, Box 669, Mineola, N.Y. 11501.

WATCHES AND CHRONOGRAPHS—Import from Switzerland, save 50%. Color catalog. DFI, West Dennis, Massachusetts 02670.

UNUSUAL BARGAINS

NICKEL-CADMIUM BATTERY BARGAINS

Terrific value—used government surplus. Quick-charge, lightweight 6-volt nickel-cadmium battery. 4-amp. hour capacity. Almost unlimited life—thousands of discharge-charge cycles with minute deterioration. Charges fully in approx. 1 hr. with Edmund Charger Kit. Hundreds of uses for hobby, photography, model building, industry, etc. Only few drops of water yearly for full maintenance. Req. minimum of electrolyte-sealed to prevent loss. Delivers nearly 100% output at below freezing. Maintains constant voltage through major portion of capacity. Five vented 1.2 volt cells strapped in 3 polypropylene bands. 3 1/4" x 2" x 6" (10 & "Jumbo" 275 Ampere Hour Batteries also available. Write for info.)
Stock No. 70,942AK \$15.00 Ppd.
1.2 VOLT NICKEL-CADMIUM CELL \$3.95 Ppd.
Stock No. 41,109AK
CHARGER KIT FOR 6-VOLT BATTERY \$8.00 Ppd.
Stock No. 70,807AK \$8.00 Ppd.

NEW SURPLUS NI-CD BATTERIES

Save more than 50%! Long life—accept 300 charge and discharge cycles. 1.25 Volts per cell—750 milliamper hours capacity. Excel. charge retention. Hermetically sealed. Indefinite storage life. Multiple cells welded in series—easily cut. Combine to form any. 7/8" dia x 1 3/8" high. Spec. price for 100 up. Low-cost charger separate.

Order #	Cells	DC Volt.	Price Ppd.
40,986AK	1	1.25	\$ 1.50
40,987AK	2	2.50	2.75
40,988AK	3	3.75	3.60
60,634AK	4	5.00	4.80
70,812AK	Trickle Charger (1-10 cells)		10.95

Order by Stock No.—Check or M.O.—Money-Back Guarantee

EDMUND SCIENTIFIC CO., 300 EDCORP BUILDING BARRINGTON, NEW JERSEY 08007

MAIL COUPON for FREE CATALOG

SEND FOR FREE CATALOG "AK"
EDMUND SCIENTIFIC CO., 300 EDCORP BUILDING, BARRINGTON, N.J. 08007
Completely new 1968 edition. New items, categories, illustrations. Dozens of electrical and electromagnetic parts, accessories. Enormous selection of Astronomical Telescopes, Microscopes, Binoculars, Magnifiers, Magnets, Lenses, Prisms. Many war surplus items for hobbyists, experimenters, workshop, factory. Mail coupon for catalog "AK".

NAME _____
ADDRESS _____
CITY _____ STATE _____ ZIP _____

CIRCLE NO. 115 ON READER SERVICE CARD

- FREE -
"HAM SHACK PAK"
\$25 WORTH OF TRANSISTORS RECTIFIERS RESISTORS CONDENSERS DIODES ETC.
Add 25¢ for handling
BOTH FREE WITH ANY \$10 ORDER

PLUS ANY **\$100** * ITEM FREE
* or items totalling \$100.00

EPOXY TRANSISTORS & IC's

- Fairchild, Motorola, Texas, Bendix
- 3-2N3683 1000 MC 200MW TRANSISTORS \$1
 - 4-2N3563 NPN, 600MC, 200MW Fairchild \$1
 - 4-2N3643 NPN, 250MC, 350MW Fairchild \$1
 - 3-8-5000 5W. 3Amp, NPN, Bendix transistors \$1
 - 4-2N4313 PNP 600MC, 200MW Fairchild \$1
 - 3-2N3565, 500HFE, NPN, 200MC, by Fairchild \$1
 - 3-2N4265, 400HFE, NPN, 350MC by Motorola \$1
 - 1-DUAL 4 IN. GATE, EXPANDER by Fairchild \$1
 - 1-QUAD 2 IN. NAND/NOR GATE \$1
 - 1-7.03 LINEAR RF AMP. Fairchild \$2.49

STEREO PREAMP 4⁹⁵
★ 8 TRANSISTORS by Fairchild
★ Ready to Play thru tape Amplifier, radio, TV
★ Volume, Tone, Controls sw

4 Transistor Amplifier
tuners, mikes, phono. **STATE 3⁹⁵**

1 AMP TOP HAT AND EPOXIES

PIV	Sale	PIV	Sale	PIV	Sale
50	5¢	800	19¢	1800	82¢
100	7¢	1000	29¢	2000	1.25
200	8¢	1200	42¢	3000	1.50
400	10¢	1400	55¢	4000	1.95
600	15¢	1600	69¢		

Actual Size → **1 AMP MICROMINIATURE SILICON RECTIFIERS**

PIV	Sale	PIV	Sale
50	7¢	600	20¢
100	9¢	800	25¢
200	12¢	1000	39¢
400	17¢		

2 AMP SILICON RECTIFIERS

PIV	Sale	PIV	Sale
200	12¢	1000	45¢
400	16¢	1200	59¢
600	19¢	1400	69¢
800	29¢	1600	89¢

1.5 AMP 2000 PIV SILICON RECTIFIERS

PRV	AMPS	AMPS
50	.35	—
100	.50	.85
200	.75	1.35
400	1.25	1.95
600	1.80	2.60

SILICON POWER STUD RECTIFIERS

PIV	3A	6A	12A	55A
50	.06	.16	.20	.50
100	.07	.22	.25	.75
200	.09	.30	.39	1.25
400	.16	.40	.50	1.50
600	.20	.55	.75	1.80
800	.30	.75	.90	2.30
1000	.40	.90	1.15	2.70

SOLITRON DEVICES, 5 AMP Epoxy Rectifiers

PIV	Sale	PIV	Sale
50	19¢	600	59¢
100	25¢	800	69¢
200	39¢	1000	89¢
400	45¢		

'GLASS AMP' SILICON RECTIFIERS

ONE AMP	PIV	Sale	PIV	Sale
	50	5¢	600	19¢
	100	7¢	800	29¢
	200	9¢	1000	39¢
	400	12¢	1200	45¢

PRV may be exceeded without the rectifier breaking down.

10¢ FOR OUR "SUMMER" BARGAIN CATALOG ON:
 Semiconductors Poly Paks Parts

POLY PAKS
TERMS: send check, money order, include postage—avg. wt. per pak 1 lb. Rate# net 30 days. CODs 25%
P.O. BOX 942W
SO. LYNNFIELD, MASS. 01940
"PAK-KING" of the World

CIRCLE NO. 99 ON READER SERVICE CARD



not by a long shot it isn't !!

There's certainly nothing top secret about the classified pages in Electronics World Magazine. They're wide open to the searching eyes of every buyer who's in the market for the product or service that he knows can be found in Electronics World's Electronics Market Place.

The more than 191,000 buyers of Electronics World, largest readership of any magazine for electronics professionals in the world, are your guarantee of knowing that your ad is being read by people who are constantly looking for and buying electronics products. It is these people to whom you MUST direct YOUR advertising as do the many key advertisers appearing in this issue and in each issue throughout the year.

No doubt about it—there's a vast market of buyers searching the classified advertising pages of Electronics World and it's important that your ad be exposed to this prime buying audience. Prove to yourself that the leading magazine for electronics professionals MUST ALSO be the leader in sales responses to the many classified ads presently enhancing its pages—it makes a great deal of sense—give it a try.

See classified section for rate information or write to
HAL CYMES, Classified Advertising Mgr.
ZIFF-DAVIS PUBLISHING COMPANY
 One Park Avenue, New York, N. Y. 10016

Deluxe ELECTRONICS WORLD MAGAZINE CASES
 DESIGNED TO HOLD A FULL YEAR'S COPIES



Constructed of reinforced fibreboard and covered in rich leatherette, these durable cases guard against soiling and tearing of your magazines while lending themselves handsomely to the decor of any room. The magazine cases are available with embossed gold lettering in either all black or attractive maroon back with black sides.

These decorative cases are just what you've been looking for to keep your copies of Electronics World Magazine in easy-to-find order.

\$3.50 ea., 3 for \$10, 6 for \$19
FULLY GUARANTEED

Ziff-Davis Publishing Co., Dept. SD
 1 Park Ave., N.Y., N.Y. 10016

Please send _____ Electronics World Magazine Cases. Also send cases for the magazine titles indicated below:

- All black, gold embossed
- Maroon back, gold embossed/black sides

NAME _____ EW-48
 ADDRESS _____
 CITY _____
 STATE _____ ZIP _____

Enclosed is \$ _____ at \$3.50 per case, 3 for \$10, 6 for \$19 (Quantity prices apply for combination orders of more than one title). Orders outside U. S. A. \$4.50 ea., 3 for \$13, 6 for \$25.

(Payment must accompany order)

ELECTRONICS WORLD APRIL 1968
ADVERTISERS INDEX

READER SERVICE NO.	ADVERTISER	PAGE NO.	READER SERVICE NO.	ADVERTISER	PAGE NO.
85	Accurate Instrument Co., Inc.	61	104	Mallory & Co., Inc., P.R.	2
125	Allied Radio	88	103	Mosley Electronics, Inc.	97
124	Arcturus Electronics Corp.	100	102	Music Associated	67
123	BSR (USA) Ltd.	12	199	N J E Corporation.....	FOURTH COVER
122	Belden Corporation	84, 85		Nationwide Tube Co.	99
121	Burstein-Applebee	64		National Radio Institute	8, 9, 10, 11
	Capitol Radio Engineering Institute, The	SECOND COVER, 1	101	Olson Electronics, Inc.	67
120	Cleveland Institute of Electronics	25	100	Oxford Transducer Co.	83
119	Cleveland Institute of Electronics	68, 69, 70, 71		Peak Electronics Co.	101
	Conar	88	193	Pennwood Numechron Co.	74
118	Cornell	102	99	Poly Paks	103
117	Delta Products, Inc.	72	98	RCA Electronic Components and Devices	15
116	Delta Products, Inc.	73	84	RCA Electronic Components and Devices	89
115	Edmund Scientific Co.	103	97	RCA Electronic Components and Devices	91
114	Electro-Voice, Inc.	86		RCA Institutes, Inc.	18, 19, 20, 21
113	Electronic Components Co.	101		RCA Sales Corp.	THIRD COVER
	Fair Radio Sales	103	96	Radar Devices Manufacturing Corp.	5
	G & G Radio Supply Company	101	95	Sams & Co., Inc., Howard W.	76
86	Gavin Instruments, Inc.	26	94	Schober Organ Corporation, The	67
81	General Electric	75	93	Scott, Inc., H.H.	74
	Goodheart Ca., Inc., R.E.	99	92	Solid State Sales	100
	Grantham School of Electronics	4	196	Solitron Devices, Inc.	7
111	Greenlee Tool Co.	74		Surplus Center	102
110	Gregory Electronics Corporation	101	90	Tescom Corporation	64
109	Heath Company	77, 78, 79, 80, 81	195	Texas Crystals	82
200	Hewlett-Packard Company	22	83	Topaz, Inc.	98
108	Johnson Company, E.F.	17	194	Trygon Electronics, Inc.	63
107	Judson Research and Mfg. Co.	87		Valparaiso Technical Institute	76
106	Kenwood	93	89	Weller Electric Corporation	65
198	Kepeco	16	88	Workman Electronic Products, Inc. ..	82
197	Lambda Electronics Corp.	66	87	Zenith	95
105	Lampkin Laboratories, Inc.	98			

CLASSIFIED ADVERTISING 99, 100, 101, 102, 103



**The simplest and most effective demonstration
of color TV fine tuning there is.**

RCA Automatic Fine Tuning.



Color TV that fine-tunes itself
when you turn it on. All you do is
sit back and write the order.

RCA



Get supermarket savings on DC power supplies by shopping at NJE.

You save 2 ways by shopping at NJE for your DC power supplies. First, you save time. NJE offers you 310 off-the-shelf models, including lab rack, $\frac{1}{3}$ rack, $\frac{1}{2}$ rack, full rack and bench mounted units. There's

no time wasted shopping around for the right power supply, or waiting on slow delivery.

Second, you save cash. NJE offers you substantial volume discounts and you're eligible for these savings even when you

order various models on a deferred delivery basis.

For complete details on supermarket savings on all 310 NJE DC power supplies, write or call for your copy of "Power Supplies Unlimited."

A SUBSIDIARY OF



CORPORATION

NJE CORPORATION
Electronic Development & Manufacturing

Kenilworth, New Jersey 07033 / (201) 272-6000
TELEFAX: FFP • TWX: (710) 996-5967

CIRCLE NO. 199 ON READER SERVICE CARD